

MORSE components production code, ECONOMY radiomodems

For equipment series: RE400

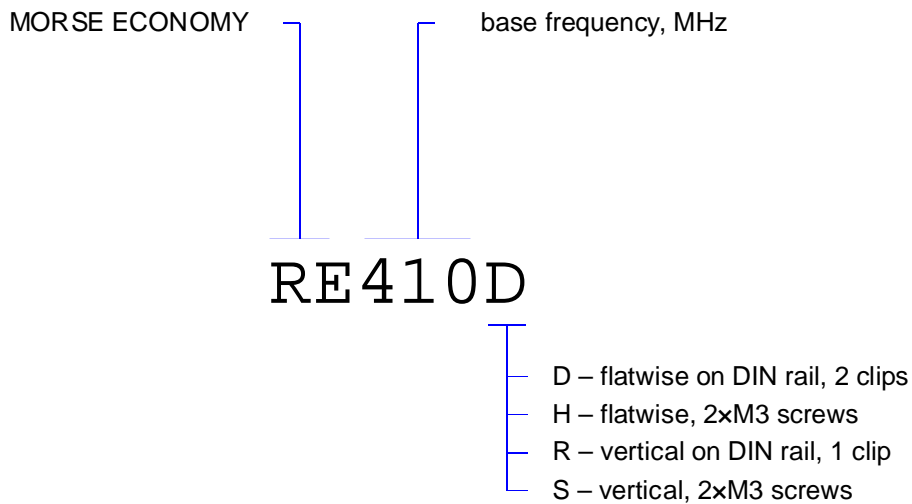

Frequencies typically produced:

RE390	373,250 – 402,000 MHz
RE410	400,000 – 420,000 MHz (398,750 – 421,500 MHz)
RE430	417,500 – 447,500 MHz
RE450	435,000 – 466,500 MHz
RE470	462,000 – 484,000 MHz

Other frequencies on request