



User Manual RAY11, RAY17, RAY24



RAY Microwave Link

fw 1.x.x.x
8/22/2018
version 3.6

Table of Contents

Important Notice	5
Quick Start Guide	6
List of documentation	7
1. RAY – Microwave Link	8
2. Implementation Notes	10
2.1. Link calculation	10
2.2. Example of microwave link design	16
3. Product	19
3.1. Range of models	20
3.2. Installation	20
3.3. Status LEDs	22
3.4. Technical parameters	22
3.5. Dimensions	23
3.6. Ordering codes	24
3.7. Accessories	25
3.8. Overview	25
3.9. Details	27
4. Step-by-step Guide	30
4.1. Service access	31
4.2. Basic link configuration	35
4.3. Link test	36
5. Installation	38
5.1. Line of sight test	38
5.2. Antenna mounting	38
5.3. Connectors	50
5.4. Grounding	56
5.5. Start up	60
6. Configuration	65
6.1. Status bar	67
6.2. Status	68
6.3. Settings	71
6.4. Diagnostics	86
6.5. Tools	91
6.6. Help	101
7. Command Line Interface	103
7.1. Connection via CLI	103
7.2. Working with CLI	104
7.3. Configuration with CLI	106
8. Troubleshooting	108
9. Technical parameters	109
9.1. General parameters	109
9.2. RAY11 A,B parameters	115
9.3. RAY11 C,D parameters	130
9.4. RAY17 parameters	136
9.5. RAY24 parameters	146
10. Safety, environment, licensing	162
10.1. Frequency	162
10.2. RoHS and WEEE compliance	162
10.3. Conditions of Liability for Defects and Instructions for Safe Operation of Equipment	162
10.4. Important Notifications	163
10.5. Warranty	164

10.6. Declaration of Conformity	165
10.7. Country of Origin Declaration	168
A. Antenna dimensions	169
B. Rain Zone Map	170
C. IP address in the PC	171
D. Linux key conversion	175
E. Https certificate	177
Index	178
F. Revision History	181

Important Notice

Copyright

© 2013 RACOM. All rights reserved.

Products offered may contain software proprietary to RACOM s. r. o. (further referred to under the abbreviated name RACOM). The offer of supply of these products and services does not include or infer any transfer of ownership. No part of the documentation or information supplied may be divulged to any third party without the express written consent of RACOM.

Disclaimer

Although every precaution has been taken in preparing this information, RACOM assumes no liability for errors and omissions, or any damages resulting from the use of this information. This document or the equipment may be modified without notice, in the interests of improving the product.

Trademark

All trademarks and product names are the property of their respective owners.

Important Notice

- Due to the nature of wireless communications, transmission and reception of data can never be guaranteed. Data may be delayed, corrupted (i.e., have errors), or be totally lost. Significant delays or losses of data are rare when wireless devices such as the RAY are used in an appropriate manner within a well-constructed network. RAY should not be used in situations where failure to transmit or receive data could result in damage of any kind to the user or any other party, including but not limited to personal injury, death, or loss of property. RACOM accepts no liability for damages of any kind resulting from delays or errors in data transmitted or received using RAY, or for the failure of RAY to transmit or receive such data.
- Under no circumstances is RACOM or any other company or person responsible for incidental, accidental or related damage arising as a result of the use of this product. RACOM does not provide the user with any form of guarantee containing assurance of the suitability and applicability for its application.
- RACOM products are not developed, designed or tested for use in applications which may directly affect health and/or life functions of humans or animals, nor to be a component of similarly important systems, and RACOM does not provide any guarantee when company products are used in such applications.

Quick Start Guide

- The default addresses of the RAY unit are 192.168.169.169/24 and 192.168.169.170/24.
- On your PC set up a similar address with the same mask, e.g. 192.168.169.180/24.
 - To configure your PC's address in Windows XP do the following: *Start – Settings – Network Connections*:
Change properties of this connection – Internet Network Protocol (TCP/IP) – Properties – Use the following IP address – input 192.168.169.180 and use the mask 255.255.255.0. Click OK twice.
- Connect both RAY units to a PoE source and connect to a PC via PoE for configuration, see Fig. Link Configuration.
- Input the address of the connected RAY unit into the address field of your internet browser (such as Mozilla Firefox), e.g. 192.168.169.169. Login as *admin* with password *admin*.
- *Status* menu provides information on connection.
- *Settings – Radio* menu enables you to change the parameters of the radio and ethernet channel, *Settings – Service Access – Users* menu lets you change login parameters.
- Continue as suggested by the Step-by-step Guide.

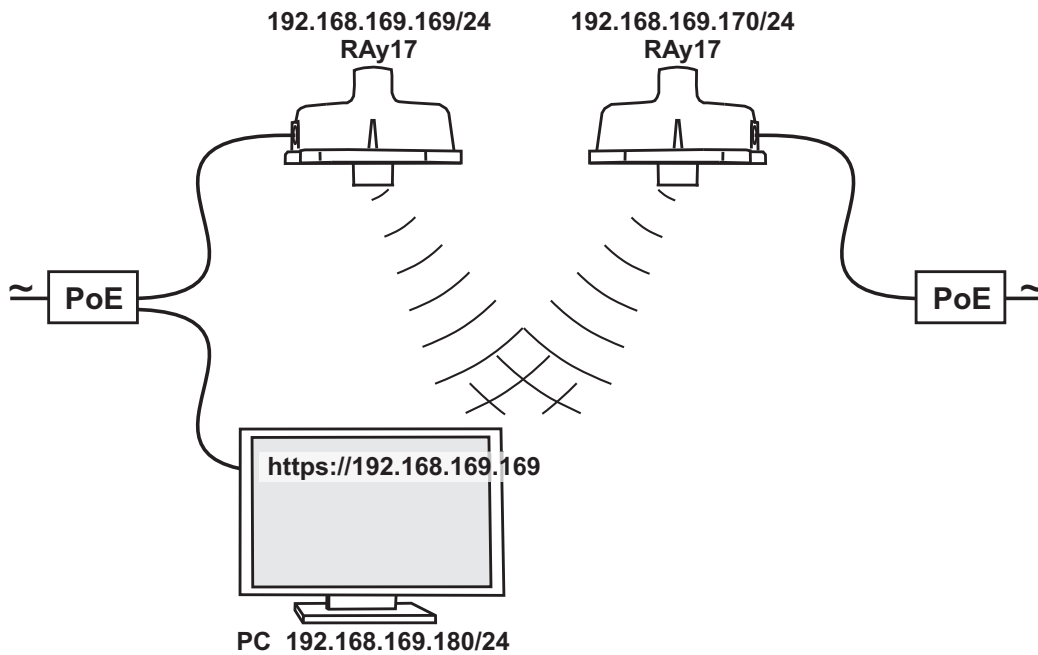

Fig. 1: Link Configuration

List of documentation

User manuals

- **Microwave Link RAY** - this document
User manual RAY11, RAY17, RAY24
- **Microwave Link RAY**¹
User manual RAY10

Specifications

- **RAY10, 11, 17, 24** - Leaflet²

¹ <http://www.racom.eu/eng/products/m/ray/index.html>

² http://www.racom.eu/download/hw/ray/free/eng/00_letaky/leaflet_RAY_en.pdf

1. RAY – Microwave Link

RAY Microwave link RAY is designed as high-speed point-to-point wireless bridge for data transmission under the latest requirements of modern wireless transmission equipment. It is built on a platform with a modern component base.

Ray works with ethernet interface and can be used in backhaul networks as well as a last-mile terminal. The design of microwave link RAY reflects effort on meeting the strictest criteria ETSI standards, particularly for durability against interference, high receiver sensitivity and high output power to achieve maximum link distance. Native gigabit Ethernet interface is able to cope with full speed user data throughput at low latency. High availability of the link (up to 99.999%) is able to be achieved with using hitless Adaptive coding and modulation.

The link properties can be summarised as:

- High data throughput
- Spectrum efficiency
- Robustness
- Security - configuration via http, https, ssh
- User friendly interface, advanced diagnostics

Key technical features

Frequency range	RAY11-A	10.700 – 10.965 GHz	Lower	11.199 – 11.455 GHz	Upper
	RAY11-B	10.945 – 11.195 GHz	Lower	11.435 – 11.695 GHz	Upper
	RAY11-C	10.5005 – 10.5425 GHz	Lower	10.5915 – 10.6335 GHz	Upper
	RAY11-D	10.5425 – 10.5845 GHz	Lower	10.6335 – 10.6755 GHz	Upper
	RAY17	17.10 – 17.30 GHz			
	RAY24	24.00 – 24.25 GHz			
Modulation		QPSK, 16, 32, 64, 128, 256 QAM		fixed or ACM	
Channel spacing		1.75, 3.5, 7, 14, 28, 30, 40, 56 MHz			
User data rate		user data rate up to 359 Mbps			
Forward Error Correction		LDPC			
User interface		1 Gb Eth (10,100,1000), (IEEE 802.3ac 1000BASE-T)			
Optional service interface		100 Mbps (IEEE 802.3u 100BASE-TX)			
Power supply PoE		40–60 VDC, IEEE 802.3at up to 100 m			
Mechanical design		FOD (full outdoor)			
Security		configuration via https, ssh			

Standards

Radio parameters	RAY11	ETSI EN 302 217-2-2 V1.3.1
	RAY17	ETSI EN 300 440-2 V 1.4.1
	RAY24	ETSI EN 300 440-2 V 1.4.1
EMC		ETSI EN 301 489-1 V1.8.1 (2008-04), ETSI EN 301 489 -17 V1.3.2 (2008-04)
Electrical safety		EN 60 950-1: 2004



Note

Operation of the RAY11, RAY17 and RAY24 is described in this user manual.
Operation of the RAY10 is described in the RAY10 User manual ¹.

¹ <http://www.racom.eu/eng/products/m/ray/index.html>

2. Implementation Notes

2.1. Link calculation

Before a microwave link can be installed, an analysis and calculation of the microwave link must be made first. The analysis should take place before the site survey itself to get a clear idea about the dimensions of the antennas. The analysis consists of the following steps:

- Free space loss calculation
- Link budget calculation
- Rain attenuation
- Multipath fading
- Fade margin
- Fresnel zones calculation

This chapter explains the individual steps and an example of link design is given at the end.

NOTE - For quick reference you can use the calculator on www.racom.eu¹

2.1.1. Free space loss calculation

As the electromagnetic waves travel through open space they are attenuated. This attenuation is described as Free-space Loss. This loss depends on the distance travelled by signal and its frequency. Longer distance means greater attenuation and higher frequency means greater attenuation. Free-space loss can be calculated thus:

$$FSL = 32.44 + 20\log f + 20\log D$$

Where:

FSL free-space loss (dB)

f frequency of the emitted signal (MHz)

D length of the link (km)

2.1.2. Link budget calculation

To goal is to design a link so that the received signal is stronger than the receiver's sensitivity at the required BER (typically 10^{-6}). Since every radio signal in earth atmosphere is subject to fading, some difference between received signal level under normal circumstances and receiver sensitivity is needed to serve as a fade margin. The minimum value of fade margin can be calculated from the requirement for link availability (e.g. 99.999% of the time). The required margin depends on the length of the link as well as other factors such as rain attenuation, diffraction and multipath propagation.

If we ignore the additional loss along the path, the received signal strenght can be calculated using the formula for signal propagation in free space as follows:

$$P_R = P_T + G_T + G_R - FSL$$

Where

¹ http://www.racom.eu/eng/products/microwave-link.html#calculation_obsah

P_R received power level (dBm)
 P_T transmitted power (dBm)
 G_T transmitting antenna gain (dBi)
 G_R receiving antenna gain (dBi)
 FSL free space loss (dB)

P_R must be:

$$P_R > P_S$$

Where:

P_S receiver sensitivity (dBm)

The receiver's sensitivity defines the minimum level of the received signal at which the receiver is able to process the received signal without losses or affecting the transmitted data (for BER better than 10^{-6}).

2.1.3. Fade margin

Determining sufficient fade margin is the most important step in microwave link design. If the margin is too small, the link will be unstable – as a result, sufficient availability of the link or quality of the provided services cannot be guaranteed. On the other hand, unnecessarily large margin makes the link more expensive (higher performance, larger and more expensive antennas) and increases the cost of creating the microwave link.

The following paragraphs describe the two most significant types of attenuation – rain and multipath attenuation, which are the most frequent along with free space loss. Mutual relation between rain and multipath attenuation rules out the possibility that the link could be affected by both types of attenuation at the same time – **these types of attenuation do not add up**. To determine the fade margin it is necessary to calculate both rain and multipath attenuation. The larger of the two types of attenuation determines the value of fade margin. In areas with high precipitation, rain attenuation can be expected to be more prominent. By contrast, links located in drier climates and little inclination, will suffer more from multipath attenuation.

2.1.4. Rain attenuation

FSL is not the only attenuation that influences the emitted signal. For frequencies of about 10 GHz rain attenuation starts to become increasingly effective. Precipitation is not identical in all areas which is why ITU released a recommendation Rec. ITU-R PN.837-1 for splitting the world into 15 regions according to precipitation intensity see Fig. 2.1, for more detail Appendix B, *Rain Zone Map*. In the areas with higher precipitation greater rain attenuation must be expected and a greater signal fade margin must be established, see the calculation of link availability.

The following properties are inherent to rain attenuation:

- It increases exponentially with rain intensity
- It becomes significantly larger as the distance travelled increases (>10 Km)
- Horizontal polarization causes greater rain attenuation than vertical polarization
- Rain outage increases dramatically with frequency and path length

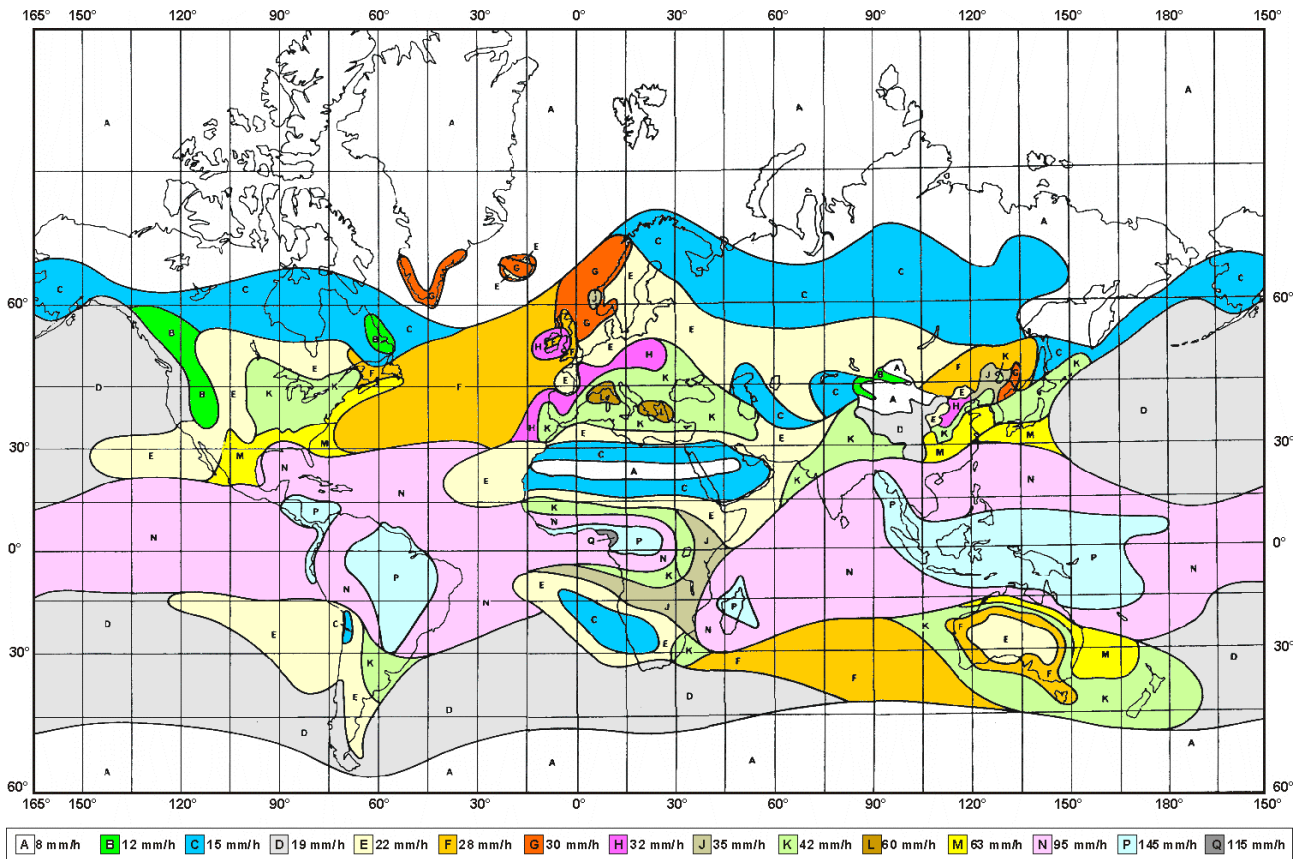

Fig. 2.1: Rain zone map, based on Rec.ITU-R PN.837-1

Rain attenuation can be calculated using ITU-R outage model, which consists of the following:

Obtain the rain rate $R_{0.01}$ exceeded for 0.01 per cent of the time (with an integration time of 1 min). $R_{0.01}$ values are defined for 15 rain zones and different time percentages and they are given in ITU-R Recommendation P.837.

Tab. 2.1: Rain rate R (mm/h) ITU-R P.837

Percentage of time (%)	A	B	C	D	E	F	G	H	J	K	L	M	N	P	Q
1.0	<0.1	0.5	0.7	2.1	0.6	1.7	3	2	8	15	2	4	5	12	14
0.3	0.8	2	2.8	4.5	2.4	4.5	7	4	13	42	7	11	15	34	49
0.1	2	3	5	8	6	8	12	10	20	12	15	22	35	65	72
0.03	5	6	9	13	12	15	20	18	28	23	33	40	65	105	96
0.01	8	12	15	19	22	28	30	32	35	42	60	63	95	145	115
0.003	14	21	26	29	41	54	45	55	45	70	105	95	140	200	142
0.001	22	32	42	42	70	78	65	83	55	100	150	120	180	250	170

Compute specific attenuation γ_R (dB/km) for the frequency, polarization, specific rain rate using ITU-R recommendation P.838. Rain attenuation for rain rate $\gamma_{R_{0.01}}$ can be calculated as follows:

$$\gamma_{R_{0.01}} = k_{h,v} \cdot R_{0.01}^{\alpha_{h,v}}$$

where:

$k_{h,v}$, $\alpha_{h,v}$ constants for horizontal and vertical polarization. Constants are slightly different for each polarization, see next table according to ITU-R P.838

Tab. 2.2: Constants k , α for horizontal and vertical polarization at 10, 11, 17 and 24 GHz

	k_h	α_h	k_v	α_v
10 GHz	0.01	1.26	0.01	1.22
11 GHz	0.02	1.21	0.02	1.16
17 GHz	0.06	1.09	0.07	1.01
24 GHz	0.14	1.01	0.14	0.96

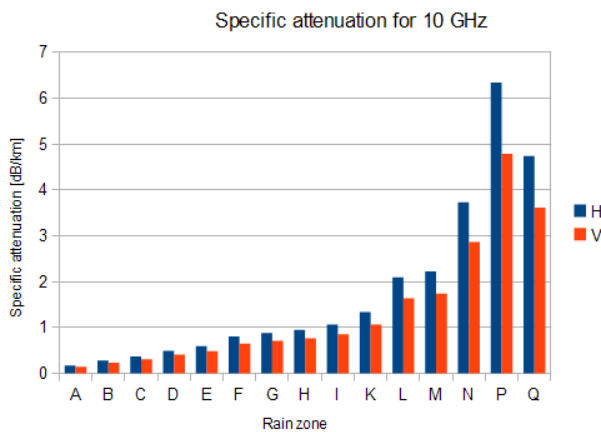

Fig. 2.2: Attenuation for 10 GHz, polarization H, V

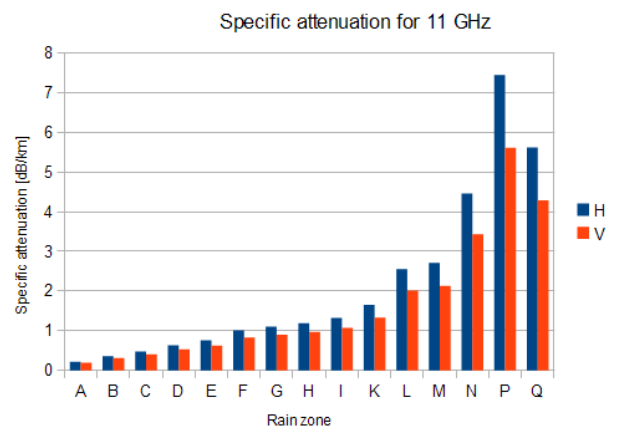

Fig. 2.3: Attenuation for 11 GHz, polarization H, V

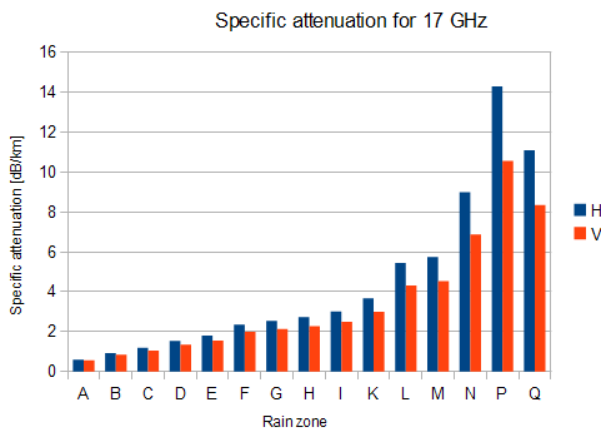

Fig. 2.4: Attenuation for 17 GHz, polarization H, V

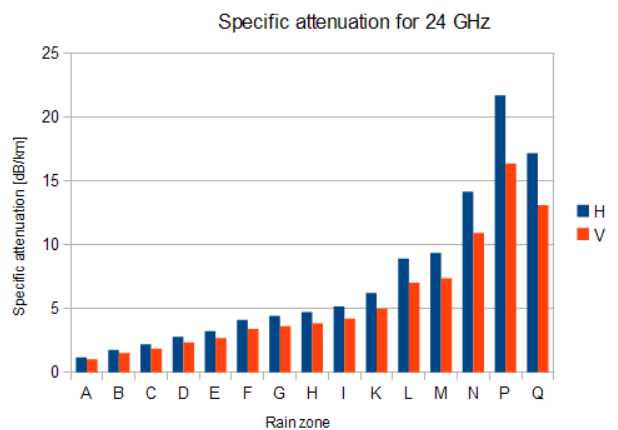

Fig. 2.5: Attenuation for 24 GHz, polarization H, V

Fig. 2.2 shows that rain attenuation is greater for horizontal polarization. In regions with higher precipitation the difference in attenuation is more marked. The microwave links RAY17 and RAY24 uses both polarizations, hence the need to consider worse of the two, i.e. horizontal polarization. When ACM is

active we recommend using horizontal polarization on the direction with lower data traffic (typically up-link).

2.1.5. Multipath fading

Multipath fading is another dominant fading mechanism. A reflected wave causes a phenomenon known as multipath, meaning that the radio signal can travel multiple paths to reach the receiver. Typically, multipath occurs when a reflected wave reaches the receiver at the same time in opposite phase as the direct wave that travels in a straight line from the transmitter.

Multipath propagation gives rise to two kinds of signal degrading effects, i.e., flat fading and frequency selective fading. Flat fading is a reduction in input signal level where all frequencies in the channel of interest are equally affected and is dependent on path length, frequency, and path inclination. In addition, it is strongly dependent on the geoclimatic factor K.

To calculate the probability of outage due to multipath propagation of microwave links ITU-R probability model can be used which describes a single frequency (or narrowband) fading distribution suitable for large fade depths A in the average worst month in any part of the world (based on ITU-R P.530-14) and for detailed link design is given as follows [1]:

$$P_0 = Kd^{3.4} (1 + |\epsilon_P|)^{-1.03} f^{0.8} \times 10^{0.00067h_L - A/10}$$

where:

d link distance (km)

f frequency (GHz)

h_L altitude of lower antenna (m)

A fade depth (dB)

K is geoclimatic factor and can be obtained from:

$$K = 10^{-4.6 - 0.0027dN1}$$

The term dN1 is provided on a 1.5° grid in latitude and longitude in ITU-R Recommendation P.453. The data are available in a tabular format and are available from the Radiocommunication Bureau (BR). E.g. in Central Europe the values dN1 range from -242 to -362.

From the antenna heights *h_e* and *h_r* (meters above sea level), calculate the magnitude of the path inclination $|\epsilon_P|$ (mrad) using the following expression:

$$|\epsilon_P| = \frac{|h_r - h_e|}{d}$$

where:

d link distance (km)

h_r, h_e antenna heights above sea level (m)

2.1.6. Fresnel zones calculation

The position of obstacles between points of the bridge can significantly influence the quality of the microwave link. The radio signal doesn't only radiate along the line of sight, but also in the area around it, i.e. in the so-called 1st Fresnel zone. Within this zone 90 % of the energy is transmitted between the transmitter and receiver antenna. This space has the shape of an ellipsoid. If it is disturbed the link has worse transmission properties and a higher quality antenna is required. For this reason the position of the antenna can be just as important as its height above ground. 60 % of the 1st Fresnel zone is considered as the most important.

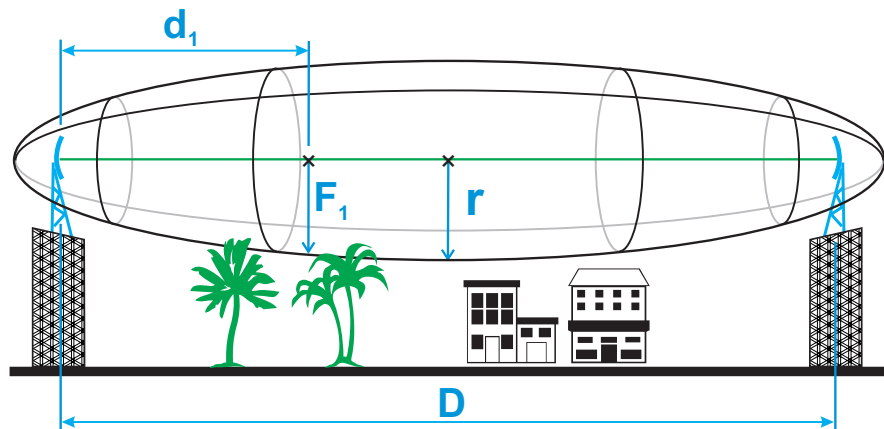

Fig. 2.6: Fresnel zone

The general equation for calculating the first Fresnel zone radius at any point P in between the endpoints of the link is the following:

$$F_1 = \sqrt{\lambda \frac{d_1 \cdot d_2}{d_1 + d_2}}$$

Where:

F_1 first Fresnel Zone radius in metres

d_1 distance of P from one end in metres

d_2 The distance of P from the other end in metres

λ wavelength of the transmitted signal in metres

The cross sectional radius of each Fresnel zone is the highest in the center of link, shrinking to a point at the antenna on each end. For practical applications, it is often useful to know the maximum radius of the first Fresnel zone. From the above formula calculation of the first Fresnel zone can be simplified to:

$$r = 8.657 \sqrt{\frac{D}{f}}$$

where:

r max radius of first Fresnel zone (m)

reducing the radius to 60% get values listed in the following table that define the space particularly sensitive to the presence of obstacles

D total link distance (km)

f frequency (GHz)

Tab. 2.3: 60 % of the 1st Fresnel zone

Length of link D	Radius of zone r for frequency		
	11 GHz	17 GHz	24 GHz
0,5 km	1.10 m	0.89 m	0.75 m
1 km	1.56 m	1.25 m	1.06 m
2 km	2.21 m	1.77 m	1.50 m
4 km	3.13 m	2.50 m	2.12 m
6 km	3.84 m	3.07 m	2.60 m
8 km	4.43 m	3.54 m	3.00 m
10 km	4.95 m	3.96 m	3.35 m
15 km	6.06 m	4.85 m	4.10 m
20 km	7.00 m	5.60 m	4.74 m
50 km	11.07 m		

2.2. Example of microwave link design

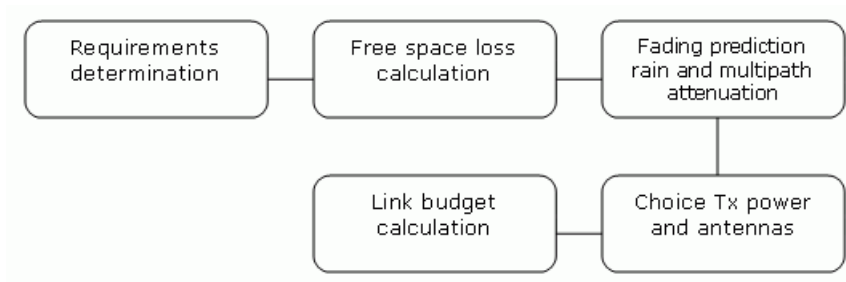

Fig. 2.7: Design flowchart

Link parameters:

- Link distance: 4 km
- First antenna height above sea level: 295 m
- Second antenna height above sea level: 320 m
- Location: Central Europe (rain zone H, refraction gradient $dN1 = -300$)

Transmission requirements:

- Required data rate: >160 Mbps
- Required availability: 99.99 %

RAy parameters:

- 17 GHz
- 161 Mbps -> Modulation 16QAM; BW=56 MHz; $P_S(\text{BER } 10^{-6}) = -79$ dBm
- Tx power +5 dBm (max. Tx power)
- Antenna gain:

- 30 cm ... 32.2 dBi
- 60 cm ... 37.8 dBi
- 99 cm ... 42 dBi

Step 1 - Free space loss calculation

$$FSL = 32.44 + 20\log f + 20\log D = 32.44 + 20\log 17.2 \cdot 10^3 + 20\log 4 = 129.1 \text{ dB}$$

Step 2 - Rain attenuation

For 99.99% availability in rain zone B the rain rate is $R_{0.01}=32$ (see Fig. 2.1)

For $f=17$ GHz $k_h=0.06146$; $\alpha_h=1.0949$; $k_v=0.06797$; $\alpha_v=1.0137$

Vertical polarization:

$$Y_{R0.01} = k_v \cdot R_{0.01}^{\alpha_v} = 0.07 \cdot 32^{1.01} = 2.32 \text{ dB/km} \Rightarrow \text{for 4km distance 9.3 dB}$$

Horizontal polarization:

$$Y_{R0.01} = k_h \cdot R_{0.01}^{\alpha_h} = 0.06 \cdot 32^{1.09} = 2.62 \text{ dB/km} \Rightarrow \text{for 4km distance 10.5 dB}$$

Step 3 - Attenuation due to multipath propagation

We have to find required fade margin for reliability of the link 99.99 percent.

Path inclination:

$$|\varepsilon_P| = \frac{|h_r - h_e|}{d} = \frac{|295 - 320|}{4} = 6.25 \text{ mrad}$$

The percentage of time that fade depth A (dB) is exceeded in the average worst month is calculated as:

$$P_0 = Kd^{3.4}(1+|\varepsilon_P|)^{-1.03}f^{0.8} \times 10^{0.00067h_L-A/10}$$

$$P_0 = 10^{-4.6-0.0027 \times (-300)} \times 4^{3.4}(1+|6.25|)^{-1.03}17.2^{0.8} \times 10^{0.032 \times 10 - 0.00067 \times 295 - A/10}$$

$$P_0 = 0.022871 \times 10^{-0.19765-A/10}$$

For reliability 99.99% is $P_0=0.01$ we get exponential function for A:

$$A = -0.19765 - 10\log(0.01/0.022871) = 3.4 \text{ dB}$$

The minimum fade margin required to suppress multipath fading on this link would be 4 dB.

Step 4 - Link budget calculation

Calculation in steps 2 and 3 determines the minimum fade margin required for stable link operation as 11 dB (rain attenuation is dominant). If you use the maximum performance of antenna with diameter of 30 cm, complete the radio formula as follows:

$$P_R = P_T + G_T + G_R - FSL = 5 + 32.2 + 32.2 - 129.1 = -59.7 \text{ dB}$$

Fade margin:

$$A = |P_S| - |P_R| = 79 - 59.7 = 19.3 \text{ dB}$$

The resulting fade margin is larger than the required 11 dB. Current legislation in the Czech Republic allows maximum EIRP of +20, i.e. the sum of transmit power and antenna gain at the transmitter can be 20 dB at the most. For 99cm antennas, TX power can be up to $20 - 42 = -22$ dB, the resultant equation is as follows:

$$P_R = P_T + G_T + G_R - FSL = -22 + 42 + 42 - 129.1 = -67.1 \text{ dB}$$

Fade margin:

$$A = |P_S| - |P_R| = 79 - 67.1 = 11.9 \text{ dB}$$

Fade margin is now only 12 dB which corresponds to link availability > 99.99% of the time in a year. Technical literature often gives the minimum fade margin of 20 dB. For very long links (more than 10 km) fade margin will, indeed, be approximately 20 dB. For shorter links, however, such large margin is not necessary. It is helpful to first conduct the calculation above to receive an idea of the attenuation affecting the link.

The result

To achieve the required transmission capacity and link availability for link distance of 4 km, transmit power -22 dBm and 99 cm antennas were selected for both sides of the link.

Sources for Chapter Chapter 2, *Implementation Notes*:

[1] Lehpamer, H.: Microwave transmission network, Second edition, ISBN: 0071701222, McGraw-Hill Professional, 2010.

ITU-R recommendation used:

- ITU-R P.453-10 – The radio refractive index: its formula and refractivity data
- ITU-R P.530-14 – Propagation data and prediction methods required for the design of terrestrial line-of-sight systems
- ITU-R P.837-1 and 6 – Characteristics of precipitation for propagation modelling
- ITU-R P.838-3 – Specific attenuation model for rain for use in prediction methods
- ITU-R P.310, ITU-R P.526, ITU-R P.676, ITU-R P.834, ITU-R P.835

3. Product

The RAY microwave links are designed for data transmissions in both licensed and unlicensed ISM bands. They work as a point-to-point link in full duplex regime with transfer speed up to 360 Mbps. Bandwidth is selectable from 1.75 up to 56 MHz. Modulation can be fixed or adaptive and can be adjusted from QPSK to 256QAM.



Fig. 3.1: RAY – Microwave link

The link is formed by two FOD (Full Outdoor) stations. In the case of links operating in the ISM bands (RAY17, RAY24), both stations have identical hardware. In the case of links operating in the licensed bands, one unit is transmitting in the Lower and receiving in the Upper part of the band. The other unit is operating vice versa.

RAY links are used with external parabolic antennas. Parabolic antennas from different producers are available.

Cross polarization - valid only for links operating in the ISM bands (RAY17, RAY24):

One side of the link uses one polarization for transmission (e.g. horizontal) and the opposite polarity for receiving (e.g. vertical). The other side of the link is turned by 90°. It therefore transmits and receives using opposite polarizations with respect to the other side.

3.1. Range of models

RAy11-LA	frequency 10.70 – 10.96 GHz, unit L
RAy11-LB	frequency 10.96 – 11.20 GHz, unit L
RAy11-LC	frequency 10.5005 – 10.5425 GHz, unit L
RAy11-LD	frequency 10.5425 – 10.5845 GHz, unit L

RAy11-UA	frequency 11.20 – 11.45 GHz, unit U
RAy11-UB	frequency 11.45 – 11.70 GHz, unit U
RAy11-UC	frequency 10.5915 – 10.6335 GHz, unit U
RAy11-UD	frequency 10.6335 – 10.6755 GHz, unit U

RAy17	universal unit for 17.10 – 17.30 GHz band
RAy24	universal unit for 24.00 – 24.25 GHz band

Every model can be supplied in two different versions:

- with one metal Ethernet port, e.g. RAY17
- with two metal Ethernet ports, e.g. RAY17-2

For details see Section 3.6, “Ordering codes”

A detailed table of frequencies can be found in Chapter 9, *Technical parameters*.

3.2. Installation

The antenna is attached to the mast using a holder adjustable in two planes. The RAY unit is then mounted on the antenna. There are two possible mounting positions – for horizontal and vertical polarization. Installation and adjustment of the holder is described in Chapter Antenna mounting.



Fig. 3.2: RAY Microwave link – antenna and FOD unit

LAN connection is possible using one or two connectors:

- The RAYXX version uses a single connector for user data, service access and PoE

- The RAYXX-2 version uses two connectors, one for user data and PoE power supply and one for service access. For assembly of connectors see chapter Connectors.

The third BNC connector serves for connecting voltmeter for RSS indication during the antenna adjustment process.



Fig. 3.3: RAY Microwave link – connectors

3.3. Status LEDs



Fig. 3.4: Status LEDs

Tab. 3.1: Meaning of LED status indicators

Diode	Colour	Function
ETH	Green	User port Flashing slowly: Auto Negotiation in progress Flashing rapidly: Link Activity 10/100/1000 Permanently lit: Link 10/100/1000
	Yellow	Management port Flashing: Link Activity 10/100 Permanently lit: Link 10/100
SYS	Green	Permanently lit: System OK Flashing rapidly: Booting Flashing slowly: Operating system in service mode
	Red	Permanently lit: Station is performing defaults. Firmware writing in progress. DO NOT POWER OFF. Flashing slowly: Serious system error.
AIR	Green	Permanently lit: AIR link OK
	Red	Permanently lit: AIR LOSS, loss of connectivity

3.4. Technical parameters

Basic technical parameters are stated in Chapter 9, *Technical parameters*

3.5. Dimensions

Communication unit ODU

- Outer size • 245 x 245 x 150 mm
- Weight • RAY11 — 2.8 kg
• RAY17 — 2.5 kg
• RAY24 — 2.5 kg

Diameters of supplied antennas

RAY units are ready for direct mounting to Jirous¹ Class 2 antennas. Individual datasheets are accessible here².

- 10, 11 GHz:
 - 38 cm, 29.0 dBi
 - 65 cm, 35.5 dBi
 - 90 cm, 37.5 dBi
 - 120 cm, 41.0 dBi
- 17 GHz:
 - 40 cm, 34.8 dBi
 - 68 cm, 38.6 dBi
 - 90 cm, 41.0 dBi
 - 120 cm, 44.6 dBi
- 24 GHz:
 - 40 cm, 36.8 dBi
 - 68 cm, 41.7 dBi
 - 90 cm, 44.0 dBi
 - 120 cm, 46.6 dBi

Andrew (Class 2 or 3) or Arkivator antennas are also possible to be used with antenna mounting kit. Flexible waveguide is a general-purpose option for any antenna usage.

Name plate

The plate contains name, bar code record, CE label, etc.:

- Type – RAY product line identification
- Code – detailed identification of the station type (see annex for details Section 3.6, “Ordering codes”)
- S/N – serial number, link contains stations with two different numbers
- MAC – HW address of user ethernet port

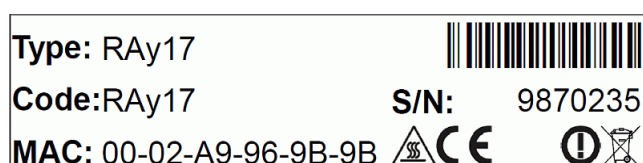

¹ <http://en.jirous.com/>

² http://www.racom.eu/eng/products/microwave-link.html#accessories_jirous

3.6. Ordering codes

3.6.1. Microwave units

The proper pair of Lower and Upper units should be selected when ordering the microwave link. This is not true for ISM bands units (RAY17, RAY24). In such a case the same unit is used for both sides of the link.

Note - The Lower and Upper unit has to be selected from the same sub-band (i.e. from the same row of the table).

The RAY10 ordering codes are stated here for clarity. The RAY10 User manual can be found here³.

Type	Licenced bands				ISM bands	
	10 GHz		11 GHz		17 GHz	24 GHz
Frequency range	A	10.30 – 10.59 GHz	A,B	10.70 – 11.70 GHz	17.10 – 17.30 GHz	24.00 – 24.25 GHz
	B	10.15 – 10.65 GHz	C,D	10.50 – 10.68 GHz		

Sub-bands	Lower [GHz]	Upper [GHz]	Lower [GHz]	Upper [GHz]	no sub-bands	no sub-bands
A ordering code	10.30-10.42 RAY10-LA	10.47-10.59 RAY10-UA	10.700-10.965 RAY11-LA	11.199-11.455 RAY11-UA	RAY17	RAY24
B ordering code	10.15-10.30 RAY10-LB	10.50-10.65 RAY10-UB	10.945-11.195 RAY11-LB	11.435-11.695 RAY11-UB		
C ordering code			10.5005-10.5425 RAY11-LC	10.5915-10.6335 RAY11-UC		
D ordering code			10.5425-10.5845 RAY11-LD	10.6335-10.6755 RAY11-UD		

ver. 3.3

In case of the two-port units, the “-2” label shall be connected to the end of the ordering code. Example:

- **RAY11-LA-2**
- **RAY17-2**

3.6.2. Feature keys

The Feature keys ordering code consists of three parts:

XXX-YYY-ZZZ

XXX - Product type, e.g. “RAY11”.

YYY - Feature key type.

The "SW" key is available now. This key unlocks the User speed to given value.

ZZZ - Feature key value. In case of User speed it states Mbps. Example:

- **RAY11-SW-100** ... RAY11 user data speed max. 100 Mbps.
- **RAY17-SW-360** ... RAY17 user data speed max. 360 Mbps.

³ <http://www.racom.eu/eng/products/m/ray/index.html>

3.7. Accessories

The microwave bridge comes supplied as standard with:

- two FOD units
- two antenna dishes with brackets for mounting on a mast – based on the user requirements and specifications
- tub of NOVATO silicon lubricant (mixture of silicon grease, PTFE and other additives) for lubricating the antenna pin. (see Section 5.2.3, “Lubrication and preservation of the antenna pivot”)

Microwave bridge accessories need to be ordered separately, for further details please see www.racom.eu⁴

3.8. Overview

RACOM-PART-NUMBER	Short description
Antenna Jirous	
ANT-JRMA-380-10/11R	Antenna parabolic 0.38 m 10-11GHz with holder 28.0-29.0 dBi Class 2
ANT-JRMA-650-10/11R	Antenna parabolic 0.65 m 10-11GHz with holder 34.1-35.5 dBi Class 2
ANT-JRMB-900-10/11R	Antenna parabolic 0.9 m 10-11GHz with holder 37.0-37.5 dBi Class 2
ANT-JRMB-1200-10/11R	Antenna parabolic 1.2 m 10-11GHz with holder 40.0-41.0 dBi Class 2
ANT-JRMB-400-17R	Antenna parabolic 0.4 m 17 GHz with holder 34.8 dBi Class 2
ANT-JRMB-680-17R	Antenna parabolic 0.68 m 17 GHz with holder 38.6 dBi Class 2
ANT-JRMB-900-17R	Antenna parabolic 0.9 m 17 GHz with holder 41.0 dBi Class 2
ANT-JRMB-1200-17R	Antenna parabolic 1.2 m 17 GHz with holder 44.6 dBi Class 2
ANT-JRMB-400-24R	Antenna parabolic 0.4 m 24 GHz with holder 36.8 dBi Class 2
ANT-JRMB-680-24R	Antenna parabolic 0.68 m 24 GHz with holder 41.7 dBi Class 2
ANT-JRMB-900-24R	Antenna parabolic 0.9 m 24 GHz with holder 44.0 dBi Class 2
ANT-JRMB-1200-24R	Antenna parabolic 1.2 m 24 GHz with holder 46.6 dBi Class 2
Antenna mounting kit	
SET-RAY10-ANW	Set mouting RAY10/11 Antenna Andrew 60, 100
SET-RAY10-ARK	Set mouting RAY10/11 Antenna Arkivator 30, 60, 99, 120
SET-RAY17-ANW	Set mouting RAY17 Antenna Andrew 30, 60, 100
SET-RAY17-ARK	Set mouting RAY17 Antenna Arkivator 30, 60, 99
SET-RAY24-ANW	Set mouting RAY24 Antenna Andrew 30, 60, 100
SET-RAY24-ARK	Set mouting RAY24 Antenna Arkivator 30, 60, 99, 120
Flexible waveguide mounting kit	
SET-RAY-FX-R100	Set mouting RAY to flange R100
SET-RAY-FX-R120	Set mouting RAY to flange R120
Power supply PoE	
PWR-POE36U-1AT	Power supply PoE 1xGb Eth 90-264 VAC/ 33.6 W at 56 VDC Pihong

⁴ <http://www.racom.eu/eng/products/microwave-link.html#accessories>

PWR-POE36D-1AT	Power supply PoE 1xGb Eth 36-72 VDC/ 33.6 W at 56 VDC Pihong
Power supply holder	
HOL-POE-PHI-1A	DIN rail holder for PoE Pihong
HOL-POE-PHI-4A	19" Rack holder for 1xPOE125U-4-AT-N Pihong
Surge protection	
OTH-DL-1GRJ45	Surge protection 1Gb Eth Cat.6 LPZ0B-LPZ1 IP20 -40/+85°C
OTH-DL-CAT.6-60V	Surge protection 1Gb Eth Cat.6 LPZ2-LPZ3 IP20 -40/+85°C
CAT7 connector	
CON-V01P-RJ45-FH	Connector RJ45 for Cat.7 outdoor IP67 -40/+70°C Weidmüller - plastic body
CON-V01M-RJ45-FH	Connector RJ45 for Cat.7 outdoor IP67 -40/+70°C Weidmüller- metal body
CON-RJ45-FH-BK	Connector RJ45 for Cat.7 indoor IP20 -40/+70°C Weidmüller - indoor
CAT7 cable	
CAB-S/FTP 4x	Cat.7 cable for connecting FOD units to the network, PEWTRONIC Ltd.
RAy grounding kit	
KIT-GROUNDING-1/4"	Grounding kit for antenna cable
KIT-GROUNDING-RAY	Grounding kit for mast grounding

3.9. Details

Antenna

The overview of different Jirous antenna types is listed in Section 3.5, “Dimensions”. The antenna choice determines radio link properties. The radio link calculation should be performed to determine proper antenna size. Rough calculation can be done using a simple on-line calculator.⁵

- see the Overview
- List of datasheets⁶



Antenna mounting kit

Other manufacturer's antennas can also be used with RAY2 links. The RAY2 unit can be attached by means of special interconnections. There are several types of these parts for Andrew and Arkivator antennas. It is also possible to develop interconnections for other antenna types.

- see the Overview
- The bracket for mounting FOD unit on the antenna.

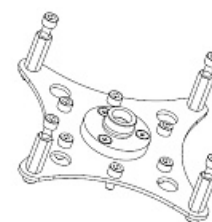

Flexible waveguide mounting kit

The RAY unit can be attached to the antenna by flexible waveguide.

- **SET-RAY-FX-R100**
- **SET-RAY-FX-R120**
- The bracket for mounting the flexible waveguide on the FOD unit.

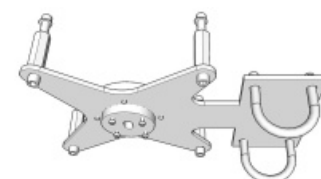

Power supply PoE

- **PWR-POE36U-1AT**
- orig. part no: POE36U-1AT
- FOD unit power supplies – 30 W PoE adapters, 1x Eth
- Input 100 to 240 VAC, Output 56 V / 33.6 W, Phihong
- Datasheet AC⁷
- **PWR-POE36D-1AT**
- orig. part no: POE36D-1AT
- Input 36 to 72 VDC / 1.2 A, Output 56 V / 33.6 W, Phihong
- Datasheet DC⁸



⁵ <http://www.racom.eu/eng/products/microwave-link.html#calculation>

⁶ <http://www.racom.eu/eng/products/microwave-link.html#accessories>

⁷ http://www.racom.eu/download/hw/ray/free/eng/07_prlusenstvi/PWR-POE36U-1AT.pdf

⁸ http://www.racom.eu/download/hw/ray/free/eng/07_prlusenstvi/PWR-POE36D-1AT.pdf

Power supply holder

- **HOL-POE-PHI-1A**
- 1x Eth PoE power supply, DIN rail mountable



Surge protection

- **OTH-DL-1GRJ45**
- orig. part no: DL-1GRJ45
- Protection from the voltage spikes
- Datasheet⁹

- **OTH-DL-CAT.6-60V**
- orig. part no: DL-Cat. 6-60 V
- Datasheet¹⁰



CAT7 connector

- **CON-V01P-RJ45-FH** ... plastic body
- **CON-V01M-RJ45-FH** ... metal body
- orig. part no: IE-PS-V01P-RJ45-FH ... plastic body
- orig. part no: IE-PS-V01M-RJ45-FH ... metal body
- Connector RJ45 for Cat.7 outdoor IP67 -40/+70°C Weidmüller



CAT7 connector indoor

- **CON-RJ45-FH-BK**
- orig. part no: IE-PS-RJ45-FH-BK
- Connector RJ45 for Cat.7 indoor IP20 -40/+70°C Weidmüller



CAT7 cable

- **CAB-S/FTP 4x**
- orig. part no: S / FTP 4x (2x23AWG) Cat.7 + 2x (2x24 AWG)
- Cat.7 cable for connecting FOD units to the network, PEWTRONIC Ltd.
- Datasheet¹¹



⁹ http://www.racom.eu/download/hw/ray/free/eng/07_prislusenstvi/OTH-DL-1GRJ45.pdf

¹⁰ http://www.racom.eu/download/hw/ray/free/eng/07_prislusenstvi/OTH-DL-CAT-6-60V.pdf

¹¹ http://www.racom.eu/download/hw/ray/free/eng/07_prislusenstvi/CAB-SFTP-4x.pdf

RAy grounding kit

- **KIT-GROUNDING-1/4"**
- Grounding kit for Cat.7 S/FTP 4x(2x23 AWG) cable. Pewtronic.
- Detail see Grounding.
- Datasheet¹²

- **KIT-GROUNDING-RAY**
- RAY grounding set for grounding RAY equipment to the mast. Contains a ZSA16 grounding terminal, grounding tape and a cable with grounding lugs.
- Detail see Grounding.
- Datasheet¹³

**Extended descriptions**

See www.racom.eu, Microwave link, Accessories¹⁴

¹² http://www.racom.eu/download/hw/ray/free/eng/07_prislusenstvi/KIT-GROUDING-RAY.pdf

¹³ http://www.racom.eu/download/hw/ray/free/eng/07_prislusenstvi/ZSA16-en.pdf

¹⁴ <http://www.racom.eu/eng/products/microwave-link.html#accessories>

4. Step-by-step Guide

The following chapters will guide you step by step through preparation, installation and activation of the RAY link:

- Pre-installation check out
- Installation
- Advanced configuration
- Troubleshooting

Pre-installation Checklist

Familiarise yourself with the controls and prepare your configuration ahead of the installation of the link on the mast tube.

Both units (without antennas) can lie on a desk with flanges running parallel and facing up at an angle, on a non-metal desk they can also face downward. In the case of units operating in the ISM band (RAY17, RAY24), turn unit holder so that they are roughly perpendicular to each other. In the case of units operating in licensed bands (RAY10, RAY11), turn unit holders so that they are roughly parallel to each other. Use an ethernet cable to connect each of the units to a PoE source and connect a PC to one of them for configuration.

Take the following steps to establish a connection between the PC and RAY and perform a basic setup.

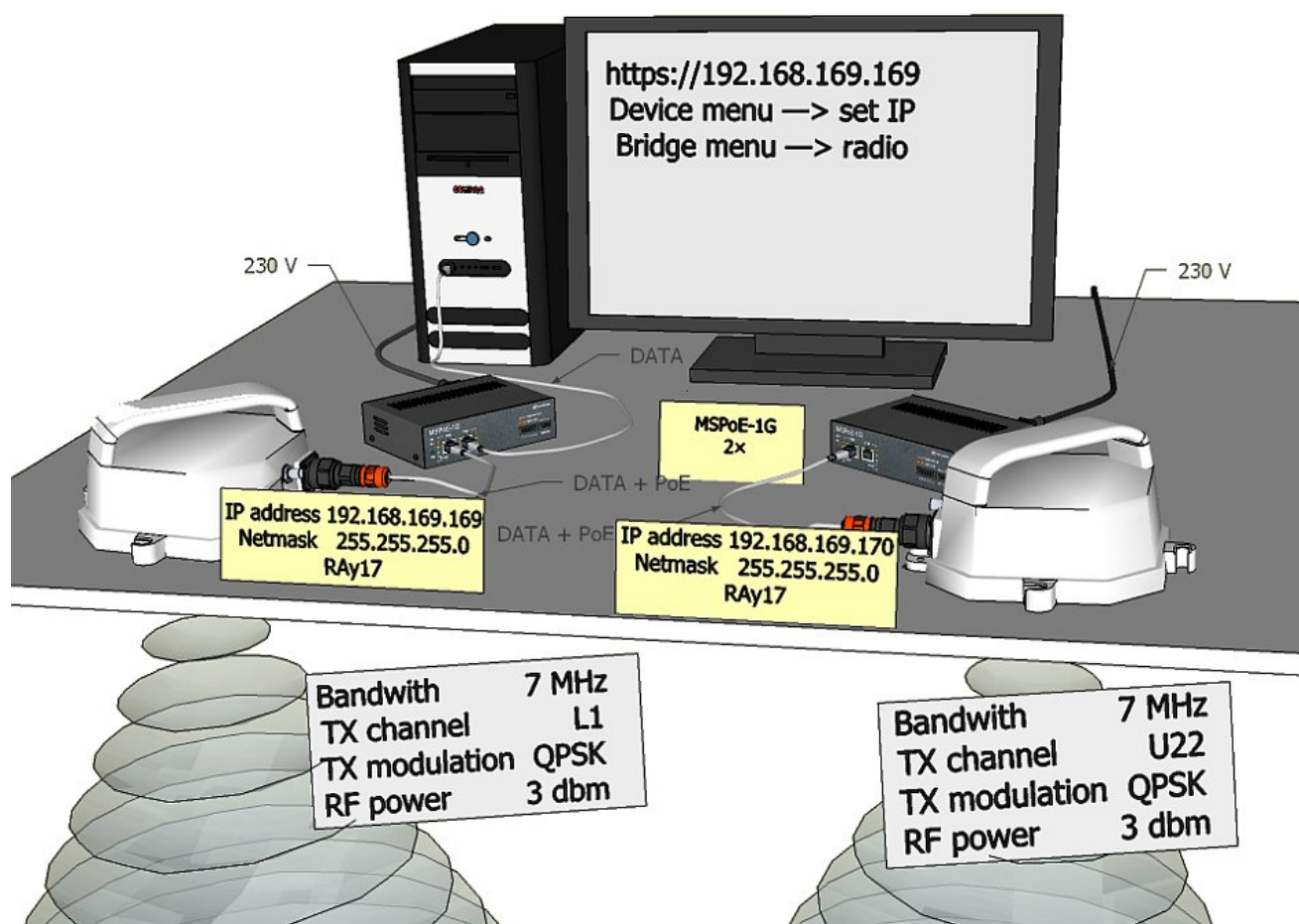

Fig. 4.1: Link Configuration

**Warning**

During operation, never bring waveguides of both stations close to each other. There is a risk of damaging sensitive input circuits.

4.1. Service access

RAY link is supplied with a default configuration of access parameters:

Unit L has the service IP address 192.168.169.169 and mask 255.255.255.0, Unit U has the service IP address 192.168.169.170 and mask 255.255.255.0, access is allowed over HTTP, HTTPS or SSH, the username is *admin* and the password is also *admin*.

On your PC setup an IP address that is within the mask, i.e. 192.168.169.180.

Then open the https configuration interface, e.g. `https://192.168.169.169`

Other access options are described in the chapter *Settings – Service Access* of this manual.

When connection has been established, use the *Settings – Service access – Services* menu to customise access parameters. Default IP addresses should be replaced with well-chosen operating addresses. Leaving default addresses in place can lead to network problems later.

The menu contains parameters for the entire link, both for the Local and remote Peer units. If a connection has been established, both sets of parameters have been set. While working with an isolated unit, only Local parameters are functional for the currently connected unit.



Note

If link is **OK** and there are no parameters shown of the station **Peer**, it is necessary to click on **Refresh**.

Follows the description of basic settings. After entering values on the screen always save the content by clicking on **Apply**.



Note

If there is any problem with https certificate after completing the firmware upgrade, please see the Annex Appendix E, *Https certificate* for further steps.

4.1.1. Menu Settings – General

- Station name – station can be assigned with a name, e.g. the place of installation.
- Station location – for easier inclusion the network hierarchy, it is possible to enter the station's location

	Local: Location_A / 12:43	Link: Ok	Peer: Location_B / 12:43
Status			
Settings			
<ul style="list-style-type: none"> > General Radio Ethernet QoS Service access Alarm limits 			
Diagnostics			
<ul style="list-style-type: none"> Graphs Logs 			
Tools			
<ul style="list-style-type: none"> Ping Graphics Maintenance 			
Help			
General			
Unit code	RAY17	RAY17	RAY17
Serial no.	28282	80808	80808
Station name	<input type="text" value="Location_A"/>	<input type="text" value="Location_B"/>	<input type="text" value="Location_B"/>
Station location	<input type="text" value="Rokytno"/>	<input type="text" value="Pohledec"/>	<input type="text" value="Pohledec"/>
LED indicators	<input checked="" type="checkbox"/>	<input checked="" type="checkbox"/>	<input checked="" type="checkbox"/>
Date	2013-04-19	2013-04-19	2013-04-19
Time	12:43:42	12:43:39	12:43:39
Time source	<input type="text" value="manual"/>	<input type="text" value="manual"/>	<input type="text" value="manual"/>
Adjust time	<input type="button" value="Adjust time"/>		
NTP source IP	<input type="text" value="0.0.0.0"/>	<input type="text" value="0.0.0.0"/>	<input type="text" value="0.0.0.0"/>
NTP period	<input type="text" value="1 m"/>	<input type="text" value="1 m"/>	<input type="text" value="1 m"/>
Time zone	<input type="text" value="(GMT) Greenwich Mean Time"/>	<input type="text" value="(GMT) Greenwich Mean Time"/>	<input type="text" value="(GMT) Greenwich Mean Time"/>
Daylight saving	<input type="text" value="off"/>	<input type="text" value="off"/>	<input type="text" value="off"/>

Fig. 4.2: Configuration Menu Settings - General

4.1.2. Menu Settings – Service access – Services

- IPv4 address – enter a valid IP address to access the drive. The default IP address has to be replaced with a valid address. Keeping the default address will probably lead to future problems in the network.
- Netmask – enter the network mask.
- Gateway – if necessary, enter a gateway, otherwise leave blank
- Enable access protocols that you are going to need. For security reasons, do not enable more than what is necessary.
- HTTP(S) – allow access to the web interface.
- Telnet – enabling access to the CLI interface using telnet protocol.
- SSH – enabling access to the CLI interface using SSH protocol.
- Management VLAN – Enabling 802.1Q VLAN tag for separation of user and service operations.
- Management VLAN id – Defining 802.1Q VLAN tag for service operations.

The screenshot shows a web interface for configuring services. At the top, a red header bar displays 'Local: Location_A / 09:33', 'Link: Ok', and 'Peer: Location_B / 09:32'. Below this, there are two tabs: 'Services' (selected) and 'Users'. The main area contains a table with two columns: 'Local' and 'Peer'. Each row represents a configuration parameter with input fields or checkboxes for both columns. At the bottom, there are five buttons: 'Apply', 'Cancel', 'Refresh', 'Load defaults', and 'Load custom'.

	Local	Peer
IPv4 address	192.168.141.226	192.168.141.227
Netmask	24	24
Gateway	192.168.141.254	192.168.141.254
HTTP(S)	<input checked="" type="checkbox"/>	<input checked="" type="checkbox"/>
Telnet	<input type="checkbox"/>	<input type="checkbox"/>
SSH	on	on
Management VLAN	<input type="checkbox"/>	<input type="checkbox"/>
Management VLAN id	1	1
SNMP	<input type="checkbox"/>	<input type="checkbox"/>
SNMP community string	public	public
SNMP trap IP	0.0.0.0	0.0.0.0
Internal link watchdog	<input type="checkbox"/>	<input type="checkbox"/>

Fig. 4.3: Configuration menu Settings – Service access – Services

4.1.3. Menu Settings – Service access – Users

- *Edit* - enter the menu.
- *New password* – choose a password and enter it.
- *Confirm password* – enter the password again to confirm.

The screenshot shows a web interface for configuration. On the left is a sidebar menu with categories: Status, Settings (General, Radio, Ethernet, QoS, Service access, Alarm limits), Diagnostics (Graphs, Logs), Tools (Ping, Graphics, Maintenance), and Help. The main area has a red header with 'Local: Location_A / 09:38', 'Link: Ok', and 'Peer: Location_B / 09:37'. Below the header are tabs for 'Services' and 'Users'. The 'Users' tab is active, showing two tables: 'Local' and 'Peer'. The 'Local' table has columns for Username, Group, Password, SSH key, and Edit. The 'Peer' table has columns for Username, Group, Password, and SSH key. At the bottom of the main area are buttons for 'Add user', 'Refresh', and 'Mirror users'.

Local				
Username	Group	Password	SSH key	Edit
super	cli_super	Set	Set	
admin	cli_admin	Set	None	Edit
guest	cli_guest	Set	None	
servis	cli_admin	Set	None	
guest2	cli_guest	Set	None	
distributor	cli_super	Set	None	

Peer			
Username	Group	Password	SSH key
super	cli_super	Set	None
admin	cli_admin	Set	None
guest	cli_guest	Set	None
pepe	cli_guest	Set	None
pepek	cli_admin	Set	None
distributor	cli_super	Set	None

Fig. 4.4: Configuration menu Settings – Service access – Services

4.1.4. Menu Maintenance – Feature keys

Firmware of the microwave link is capable of limiting the maximum user data speed. The Feature key to unlock specific user data speed should be installed prior to unit physical installation. The microwave link can be operated only at the lowest speed (according to link type down to 5 Mbps) without the installed Feature key. For further details see Feature keys.

4.2. Basic link configuration

Default radio parameters depend on the specific type of link and the specific channel allocation table. Channels are typically set in the lower part of the band, the smallest bandwidth, QPSK modulation, and low power. Both units in the pair should be capable of immediate communication. If it is possible to work with these radio parameters at the installation location, the link can be activated. On an operating link, required operating parameters can then be set up.

If a change in the parameters is necessary, it is done in the menu *Settings – Radio* and saved by clicking Apply. This applies when working on both units simultaneously if they are connected, otherwise each unit is configured individually. When configuring units individually, pay attention to correct settings of duplex pair for channels TX and RX. For example, if one station has TX channel L1, then the second station must also have the channel RX L1.

4.3. Link test

Verify the functionality of the radio link. Switch in screen Status - Brief:

- Status Bar displays *Link: Ok*.
If the alarm message appears at Local or Peer, this doesn't necessarily mean there is a problem. The message indicates that the limit at any of the monitored parameters has been exceeded. Essential is the *Link: Ok* message.
- The *Status* screen contains values for both Local and Peer units. N/A next to Peer indicates that the data from the Peer unit has not been transferred. If *Link* is *Ok*, simply click Refresh at the bottom of the screen and Peer data will be updated.
- Menu *Status – Detailed – Radio* indicates link RSS and SNR values, in case of ACM also the selected modulation and Netbitrate. If the ATPC function is enabled (menu *Settings – Radio*) it also indicates instantaneous / max. allowed power and for SNR and RSS values it indicates immediate / target value size.
- Menu *Tools – Graphics – Bar indicators* display current size of RSS, SNR and BER.
- Menu *Tools – Ping* allows you to send a ping test to the selected IP address.

Try out the possibility of modulation:

- Modulation ACM. In menu *Settings – Radio* enable ACM. Set the TX modulation parameter to the required maximum value. In menu *Status – Brief – Radio* you can monitor (Refresh or Start) changes in used modulation based on the instantaneous SNR signal quality. Status and quality of modulation is demonstrated well in menu *Tools – Graphics – RX constellation diagram*, hit Refresh.
- To set a fixed modulation go to *Settings - Radio*, switch off ACM and set the TX modulation to a value from the range of QPSK through 256-QAM based on the results of the previous test. If you choose modulation higher than allowed by SNR, the connection will be lost. *Status Link* will lose its *Ok* value. Both units will need to be moved closer to resume the link. If this is not possible, use ethernet to access each unit individually and set the basic modulation QPSK. You can monitor the quality of the received signal under *Tools – Graphics – RX constellation diagram*.

Verify the functionality of the entire link:

- If possible, connect user devices to both RAY units over PoE and test mutual communication.
- Another way of testing this is to connect a PC to the other unit and send a ping from one PC to the other.
- The minimum variant of this test is to use ethernet cable connection from the PC connected to the local RAY to the PC connected to the remote RAY and test communication between both units over ethernet. This will verify ethernet functionality.

Prepare installation configuration:

- Bandwidth e.g. 3.5 MHz. To get the highest possible receiver sensitivity, set the bandwidth as narrow as possible according to specific frequency band.
- TX channel: Use your allocated channel. If you don't have allocated channel yet, use for example channel L1.
- RX channel will setup automatically when channel lock activates.
- TX modulation QPSK to get the highest possible sensitivity.
- RF power according to selected antenna and according to individual frequency licence. Set the output power as high as possible.
- Record the access parameters from the Service access menu, especially the IP addresses.

- Restart by interrupting power supply to verify that the parameters are stored correctly and the link works.

After this preparation phase you can continue to install your devices in working environment.

5. Installation

5.1. Line of sight test

Before you install the device to a mast tube, verify visually that the view in direction of the remote unit is unobstructed. Watch out for these obstacles in particular:

- Free Fresnel zones. Signal needs space wider than the diameter of the antenna.
- Trees at the lower end of the Fresnel zone. They will be taller in a few years.
- Possible building development.
- Objects in the close proximity of the antenna such as edges of other antennas, their mounting racks, edges of the roof.

5.2. Antenna mounting

5.2.1. Mounting methods

- according to the method of mounting on the mast tube
 - right-side mounting
 - left-side mounting
- according to the method of mounting the FOD unit – antenna polarization
 - horizontal mounting
 - vertical mounting

In both cases mount the unit with the connectors facing downwards at an angle.

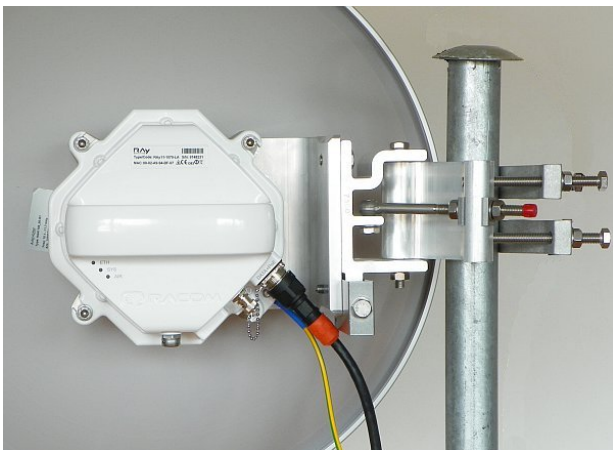

Fig. 5.1: Left-side mounting – horizontal polarization of receiving

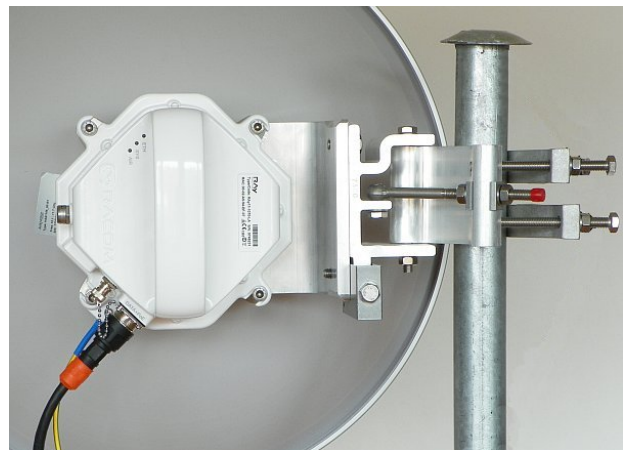

Fig. 5.2: Left-side mounting – vertical RX polarization

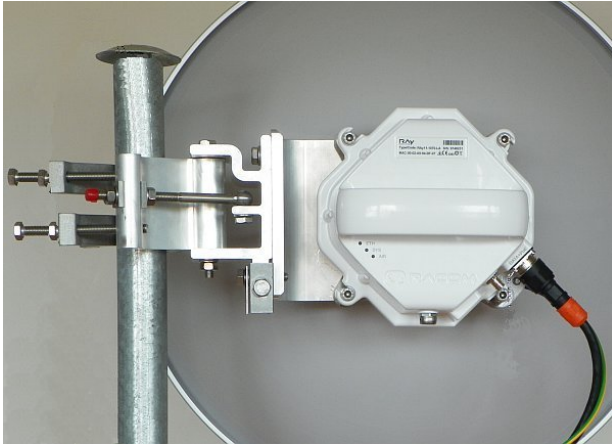

Fig. 5.3: Right-side mounting – horizontal RX polarization

Changing the mounting method

Antenna bracket is supplied as standard partly assembled, and ready for right-side mounting.

On changing the **Jirous** antenna bracket for left-side mounting the adjustment bolt (part No. 11) and swivel bolt (part No. 12) need to be unscrewed, then shift the bracket body (part No.13) to the other side of clamp plate (part No. 4), (do not turn upside down) and then insert bolt (part No. 12) into the second hole on the mounting plate holder and through the same hole on the clamp plate and secure in place with the nuts. The adjustment bolt (item No. 11) and nuts (item No. 9) are switched to the other side of the clamp plate (part No. 4). It is also necessary to switch the hanging bolt (part No. 7) on the mounting plate (part No. 5) to the second hole so that after switching sides with the antenna it is on the top again.

On changing the **Arkivator** type antenna bracket for left-side mounting the adjustment pin (part No. 17) needs to be unscrewed and switched to the other side of the bracket body (part No.3) and clamp plate (part No. 4). It is also necessary to switch the adjustment bolt (part No. 21) and U-plate (part No. 13) to the other side of the bracket body (part No.3). This ensures that there is still good access to the adjustment elements for changing the direction of the antenna when mounted on this opposite side.

In the case of the antenna when changing the method of mounting from right-side to left-side it is only necessary to change the eye hook on the top and rotate the plastic cover of the antenna. This is not only important from an aesthetic point of view, so that the RACOM logo is not upside down, but also because there is a discharge channel on the lower edge of the dish (except for $\varnothing 380$ mm dishes).

When changing the polarization from horizontal to vertical only the FOD unit needs to be turned through 90° around the central antenna pin by unscrewing the four bolts on the dish using a No. 6 Allen key. (or on the reducing crossplate (part No. 7) for the Arkivator type antenna)



Important

The RAY17 and RAY24 links are equipped with a polarization duplexer and work in both polarizations simultaneously, see Cross polarization. One side of the link must therefore be installed in vertical polarization and the other in the horizontal polarization.

5.2.2. Mounting the FOD unit on the antenna

RAy microwave bridge equipment is generally supplied as several component parts packaged separately in a box.

- Two parabolic antennas.
- Two brackets for mounting the antenna to the mast.
- Two FOD stations, each separate in a box, in a single package.
- Other accessories based on the order placed (for more detailed information see chapter Section 3.7, "Accessories")

When ordering a RAY microwave bridge there is a choice of antennas from two manufacturers to be connected to the RACOM FOD unit.

Mounting the FOD unit on the Jirous antenna

A No. 17 spanner and a No. 6 Allen key are required for mounting the mechanical parts of the antenna. Spanner No. 17 serves for precisely setting the direction of the antenna. Both spanner and key can be found in the **RAY Tool** set for installing RAY microwave bridges.

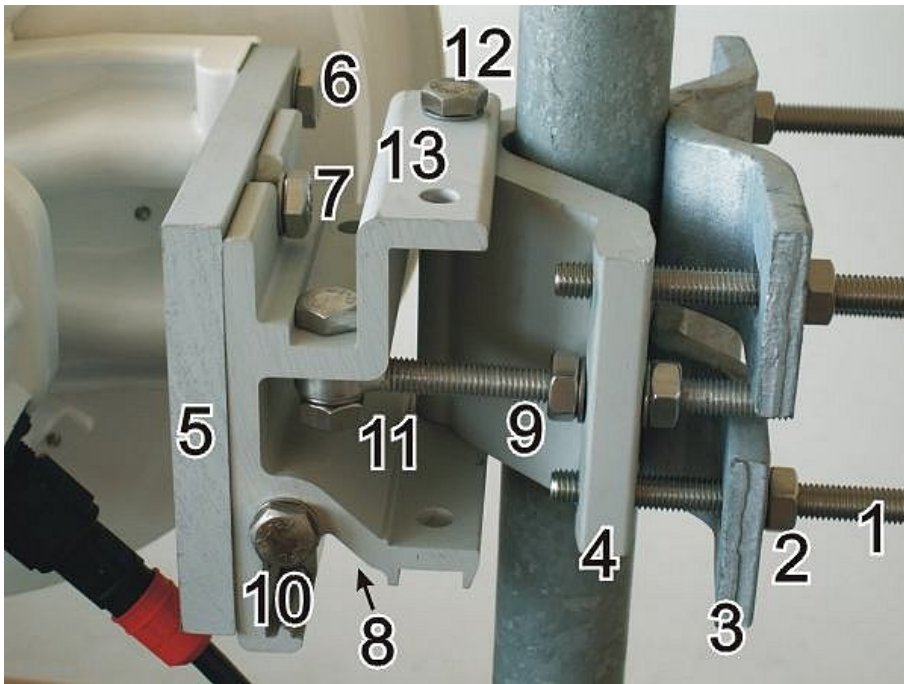

Fig. 5.4: Close up image of the mounted bracket showing numbered parts

- a. Prepare the antenna bracket based on the diameter of the mast tube. For smaller diameters face the bent part of the saddle plate (part No. 3) inwards. For larger diameters it should face outwards. Screw the bolts (part No. 1) into the clamp plate (part No. 4) so that they protrude approx. 1 cm through the clamp plate. Clamp the saddle plate to the mast by tightening the nuts (part No. 2) on the bolts.

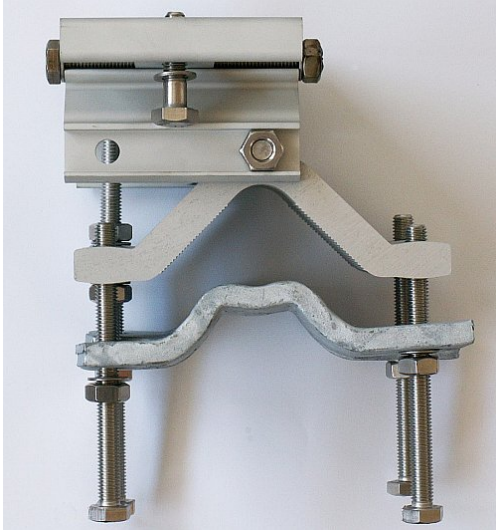

Fig. 5.5: Position of the saddle plate for \varnothing 40–80 mm

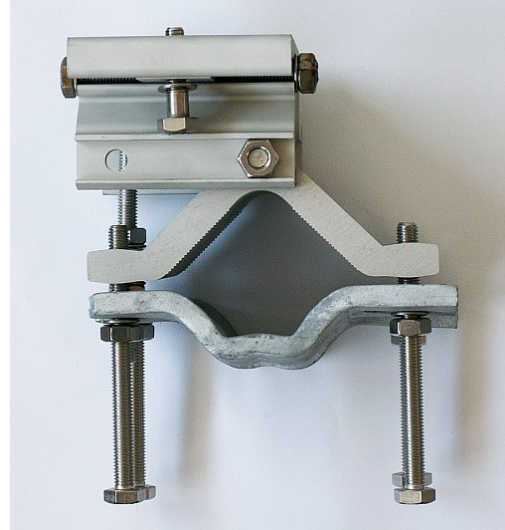

Fig. 5.6: Position of the saddle plate for \varnothing 65–115 mm

- b. Slide the antenna bracket onto the mast tube and clamp to the mast by tightening the nuts.

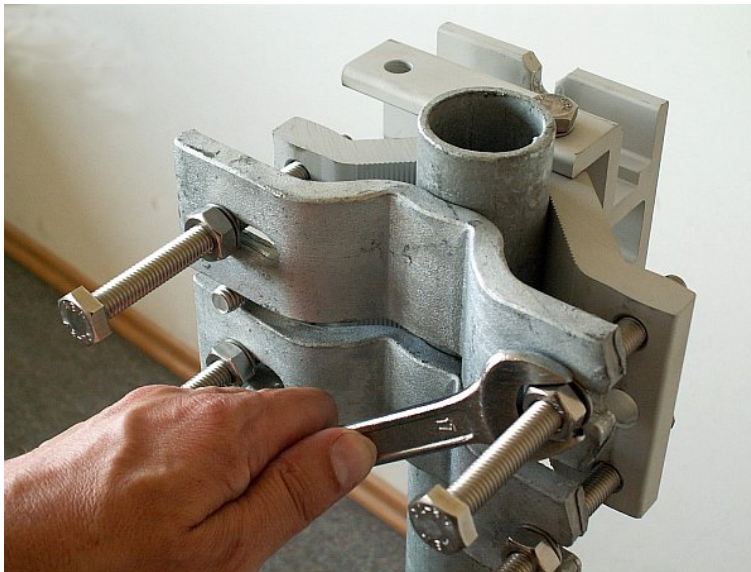

Fig. 5.7: Attaching the bracket to the mast tube

- c. The second part of the bracket – mounting plate (part No. 5), is screwed to the antenna dish with three bolts (part No. 6). Screw the eye hook into the upper threaded hole of the dish to ease handling of the dish during installation. The position of the eye hook on the dish and hanging bolts on the plate change according to the type of installation, see Section 5.2.1, “Mounting methods”.



Fig. 5.8: Dish without mounting plate

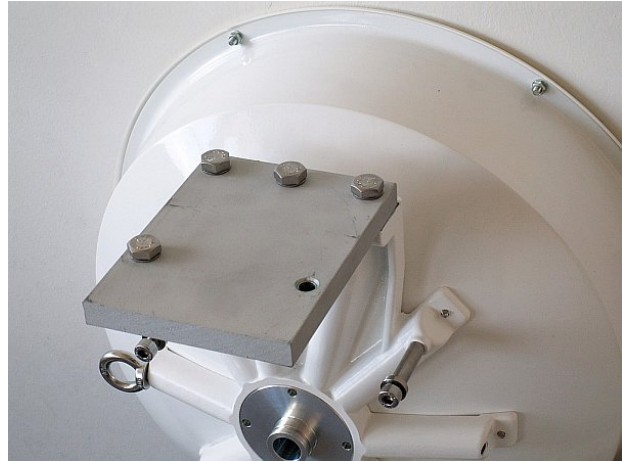

Fig. 5.9: Dish with mounting plate

- d. Screw the hanging bolt (part No. 7) into the upper hole of the mounting plate so that the antenna can be hung on the mounting plate holder. Hang the antenna on it and tighten the lower bolt. (part No. 8)

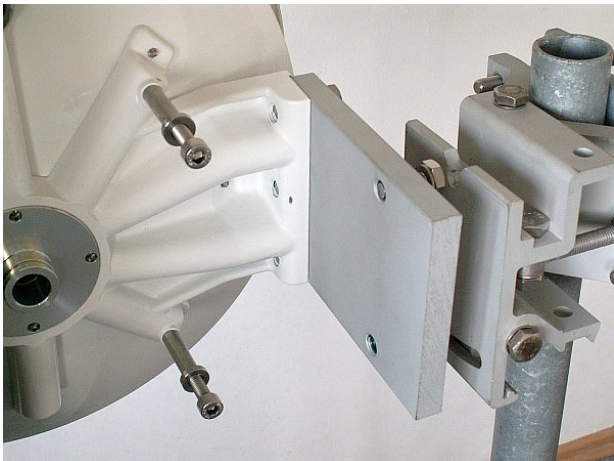

Fig. 5.10: Hanging the bolt on the holder



Fig. 5.11: Correct position of the mounting plate

- e. Tighten both bolts to the plate before continuing with installation to prevent any unnecessary movements of the whole equipment. Before precisely adjusting the vertical direction of the antenna upon completing installation it will be necessary to unscrew them again as the lower bolt passes through the adjustment block and the upper one serves as the axis of rotation.

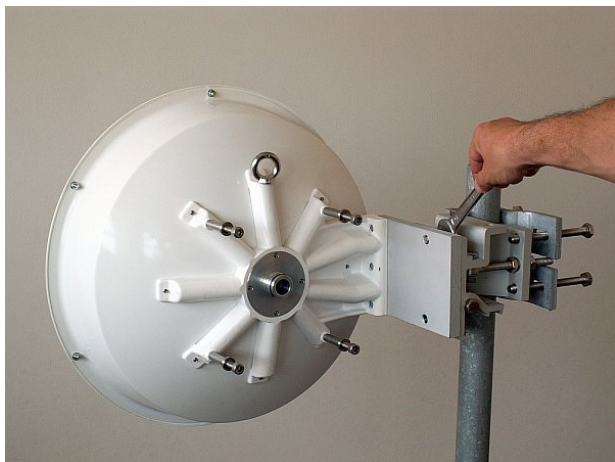

Fig. 5.12: Tightening the upper bolt to the mounting plate

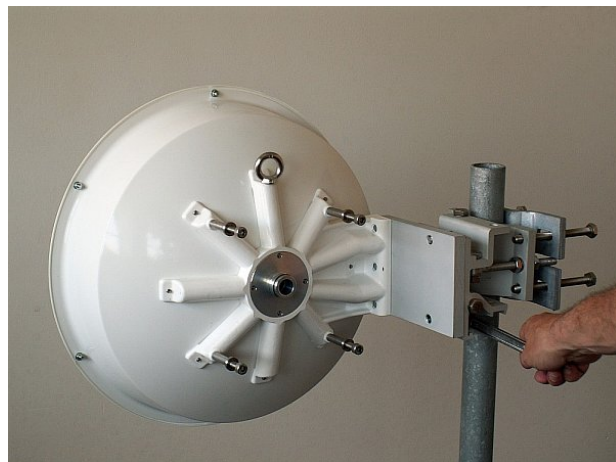

Fig. 5.13: Tightening the lower bolt to the mounting plate

- f. Before installing the FOD unit on the antenna first unscrew the 4 bolts on the back of the antenna enough so that the unit can be slid on to them. Then check whether the "O" ring is correctly fitted on the antenna pin, and make sure it is not damaged and has been lubricated with grease – see Section 5.2.3, "Lubrication and preservation of the antenna pivot". Then remove the protective plastic cover from the central pin of the antenna and fit the FOD unit to it carefully so as not to damage the "O" ring. Secure it in place with the four bolts. Carefully ensure the correct polarization of the antenna – see Section 5.2.1, "Mounting methods". Finally tighten the bolts with a No. 6 Allen key.

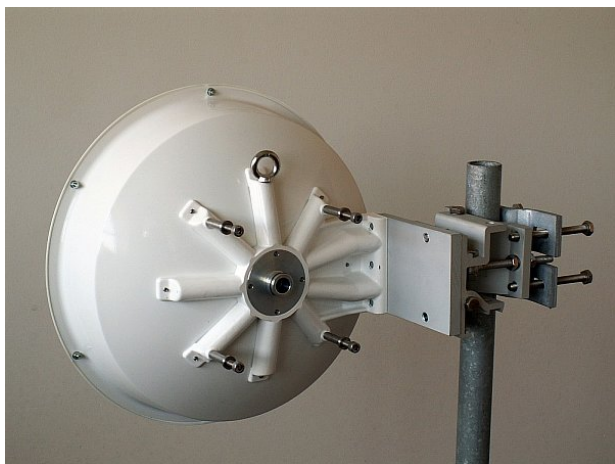

Fig. 5.14: Dish before installing the FOD unit



Fig. 5.15: Tightening bolts on the FOD unit

- g. The precise horizontal direction the antenna is pointing in can be adjusted using the bolt with two nuts (part No. 9). Once the direction has been set the antenna is fixed in place by tightening the nuts against the bracket to prevent further movement of the antenna. The vertical direction the antenna is pointing in can be adjusted by turning the fine adjustment bolt (part No. 10) by the bracket mounting plate. After selecting the correct direction the position is secured by tightening the bolt – see point e (part No. 7 and 8). The correct position in both directions is found by monitoring RSS – voltmeter, or with an audible alarm (if equipped) – see Section 5.5.2, “Antennas directing”.

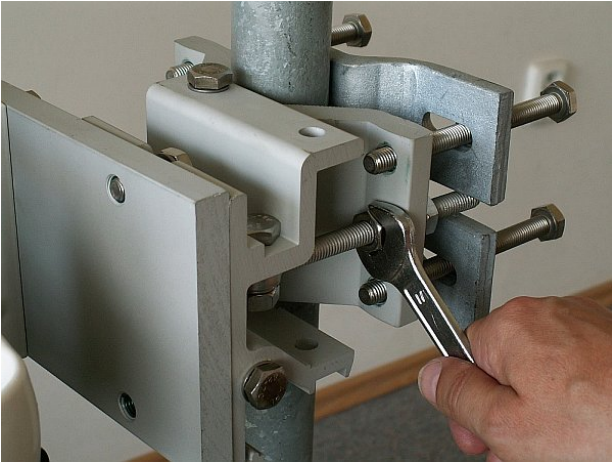

Fig. 5.16: Horizontal adjustment of the antenna direction

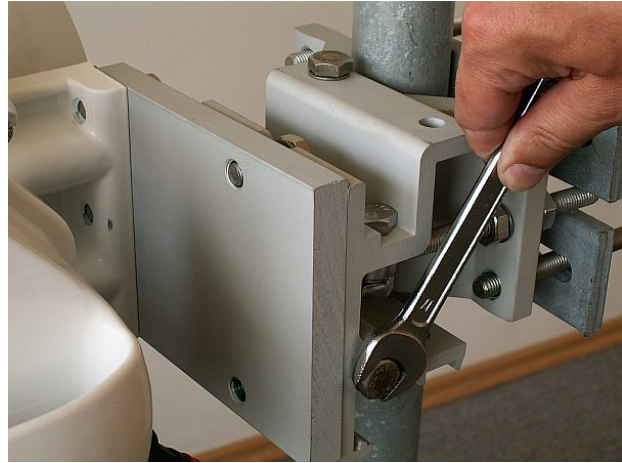

Fig. 5.17: Vertical adjustment of the antenna direction

- h. After pointing the antenna in the right direction tighten the bolts on the bracket on the axes of rotation (part No. 11 and 12). Then check again that all other bolts have been sufficiently tightened. We can now proceed to connecting the FOD unit to the user network.

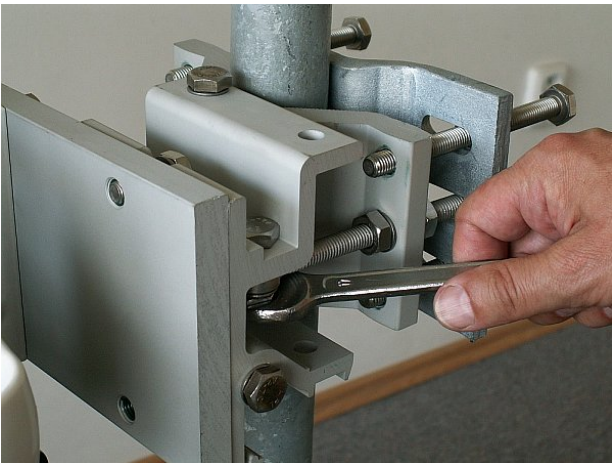

Fig. 5.18: Tightening the axis at the fine adjustment bolt

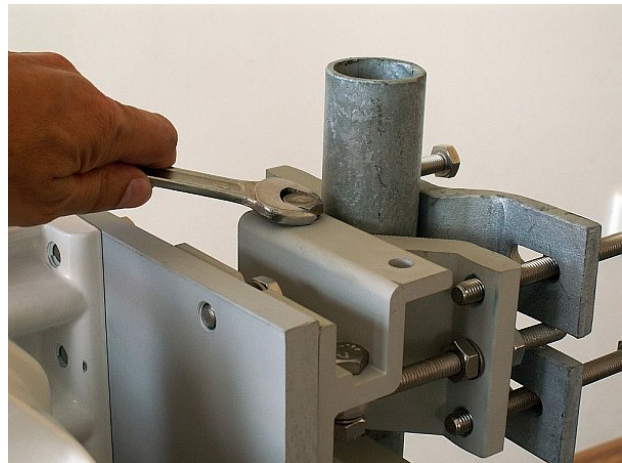

Fig. 5.19: Tightening the axis at the bracket

Mounting the FOD unit on the Arkivator antenna

Installation of a RAY microwave bridge with an Arkivator type antenna is very similar to the installation described above, and is clear from the following images. The tools required for installation can be found in the **RAY Tool** kit for installation of RAY microwave bridges. No. 13, 16 and 17 spanners and No. 4 and 6 Allen keys are required for installation. For an antenna with a nominal diameter of 120 cm a No. 14/24 double open ended spanner, supplied with the antenna.

From 2013 Arkivator antenna is delivered with a slightly different bracket, see Fig. 5.24, "Arkivator antenna bracket, version 2013". Assembly process is similar.

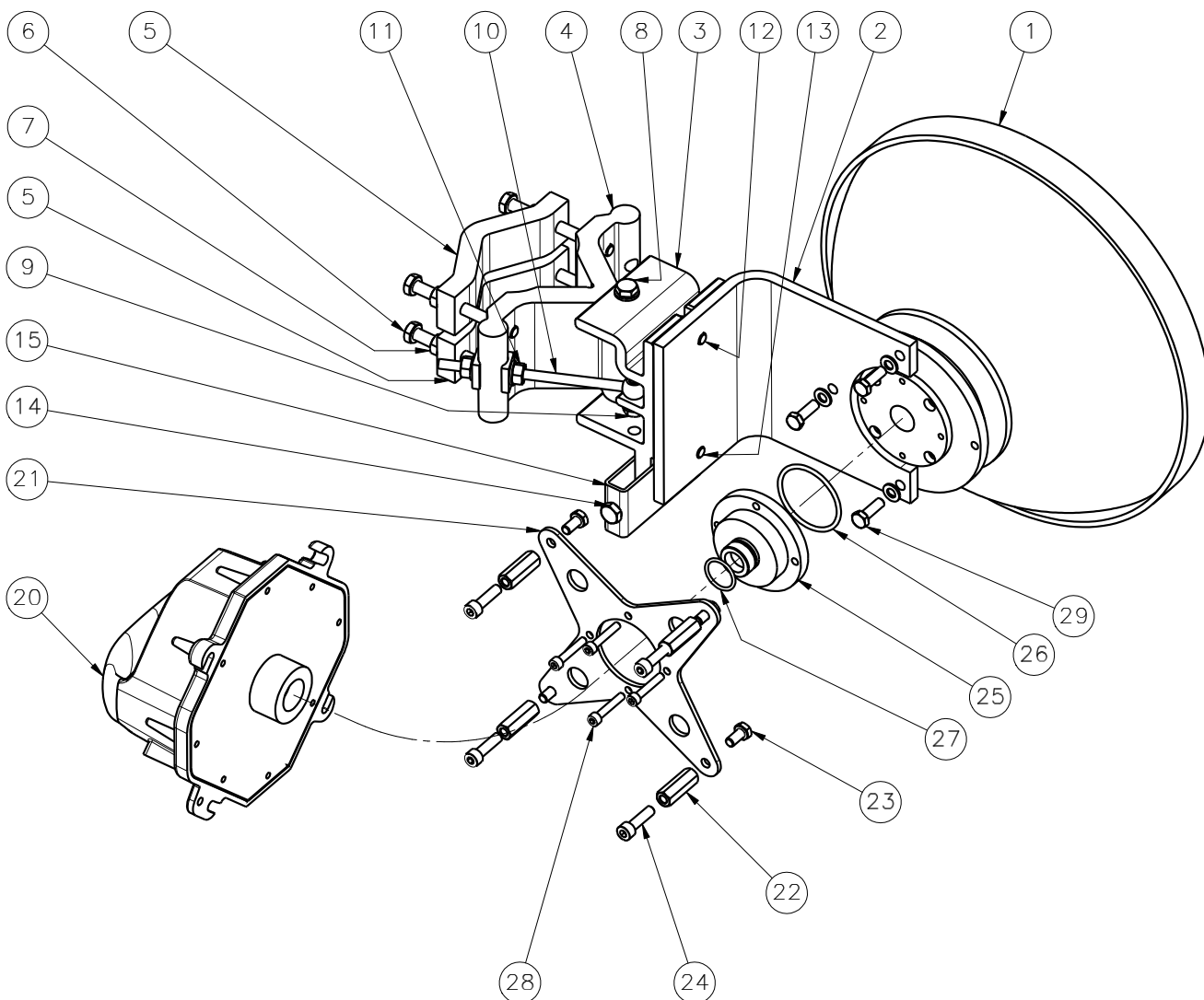

Fig. 5.20: Installation diagram for the Arkivator antenna, 30 and 60 cm, version 2012

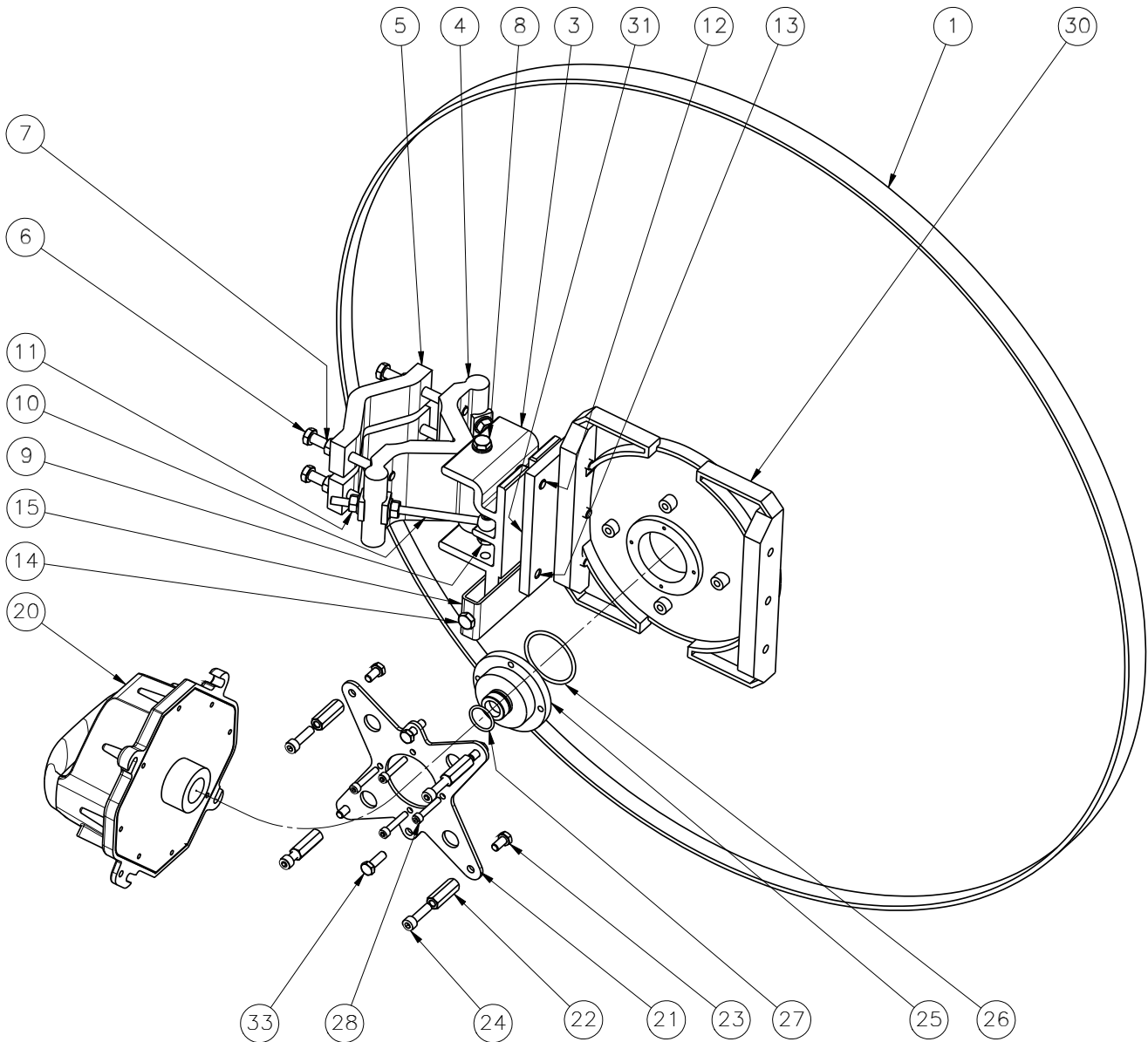

Fig. 5.21: Installation diagram for the Arkivator antenna, 99 cm, version 2012

The antenna bracket (part No. 3 and 4) is supplied assembled as per the following image. The bracket is installed on the mast tube in a similar way to that of the Jirous antenna (point a). The bracket is ready for tube diameters up to 115 mm. The bolts (part No. 6) should be screwed to the clamp plate (part No. 4) in such a way that the end of the bolt protrudes approx. 6-10 mm through the other side of the clamp plate. Saddle plates (part No. 5) are then clamped against the mast tube by tightening nuts (part No. 7).



Warning

Before mounting the adapter (part No. 25) to be removed the green foil from the antenna (part No. 1). This film covers the transport of the center hole in the waveguide.

After mounting the bracket on the mast tube, bolt the bent plate (part No. 2, for Arkivator 30 and 60) or (part No. 30, for Arkivator 99) to the bracket. The actual antenna (part No. 1) is then bolted to this plate.

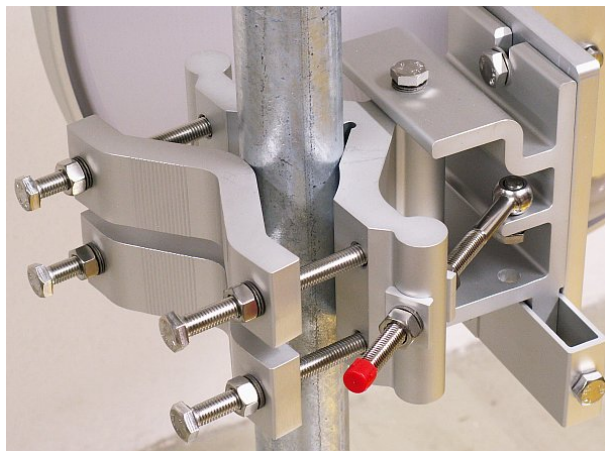
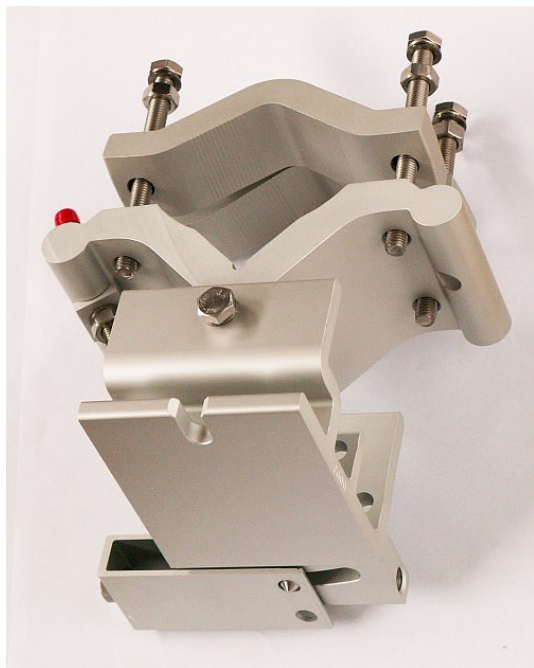

Fig. 5.22: Arkivator antenna bracket (2012) Fig. 5.23: Bracket on the mast, version 2012

A reducing adapter (part No. 25), a reducing crossplate (part No. 21) and sleeves (part No. 22) are used for mounting the FOD unit (part No. 20) on the antenna. During installation do not forget "O" rings (part No. 26 and 27) and to lubricate the "O" ring (part No. 27), see Section 5.2.3, "Lubrication and preservation of the antenna pivot".

Bolt (part No. 14) serves for accurately setting the vertical direction of the antenna. When setting the direction release bolt (part No. 12 and 13), and then tighten it again once you have the correct position. The nuts on bolt (part No. 10) serves for setting the horizontal direction. Once the direction is set these nuts (part No. 11), pivot bolt (part No. 9) in the hanging eye of bolt and two pivot bolts (part No. 8) where the tilt bracket is need to be tightened.

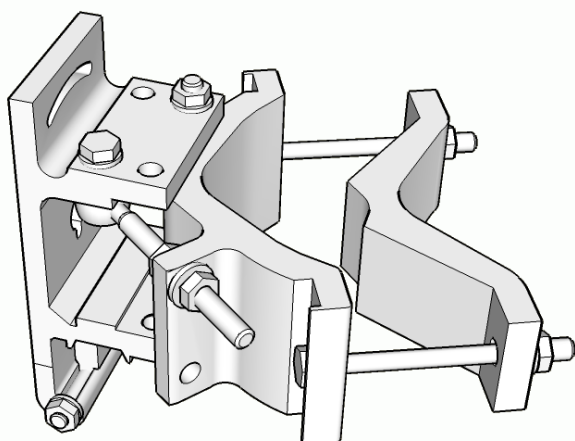

Fig. 5.24: Arkivator antenna bracket, version 2013

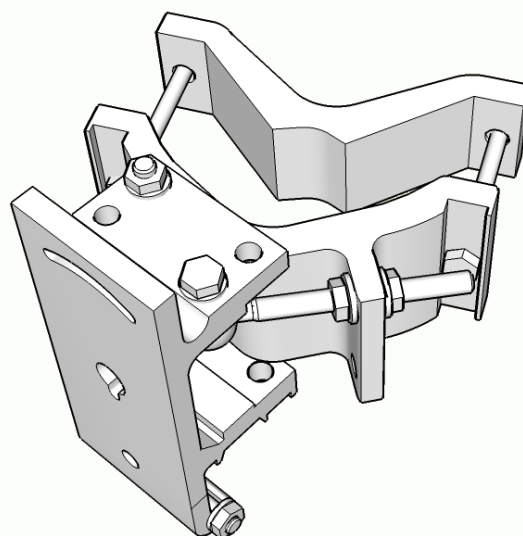

Fig. 5.25: Arkivator antenna bracket (2013)



Fig. 5.26: 30 and 60 cm diameter Arkivator antenna

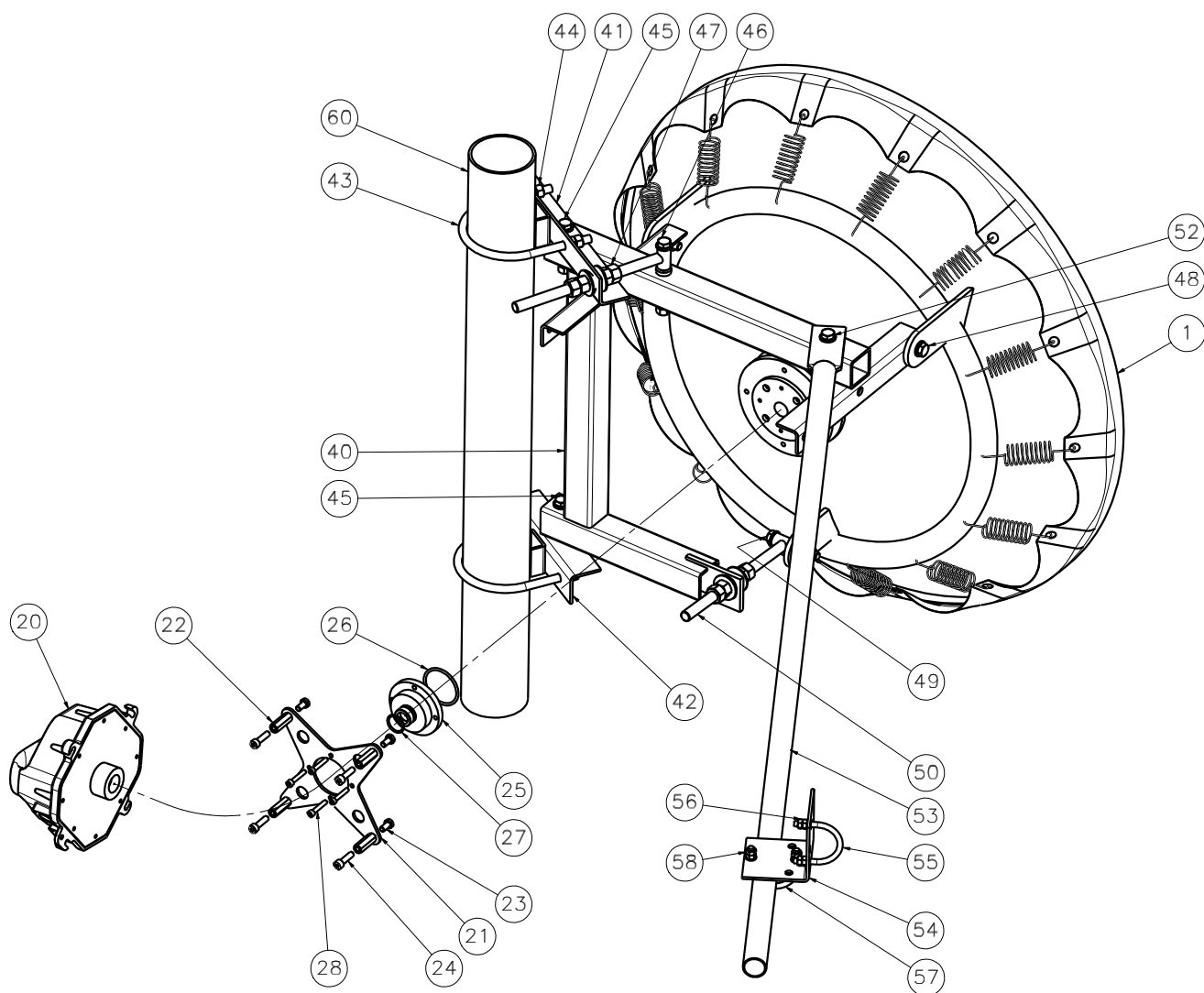

Fig. 5.27: Installation diagram for the Arkivator antenna, 120 cm

5.2.3. Lubrication and preservation of the antenna pivot

Before fitting the FOD unit bush onto the antenna pivot ensure that the "O" ring (part No. 1) is in the correct position. It is also essential to prevent moisture getting in between these two parts. This moisture could cause oxidation which would complicate disassembly of this mechanical coupling in the future. For this reason we need to treat these surfaces with the lubricant grease which is supplied in the box marked RAY bridge accessories. If you use a different grease for lubrication then it should be a Teflon grease or a silicon lubricant grease.

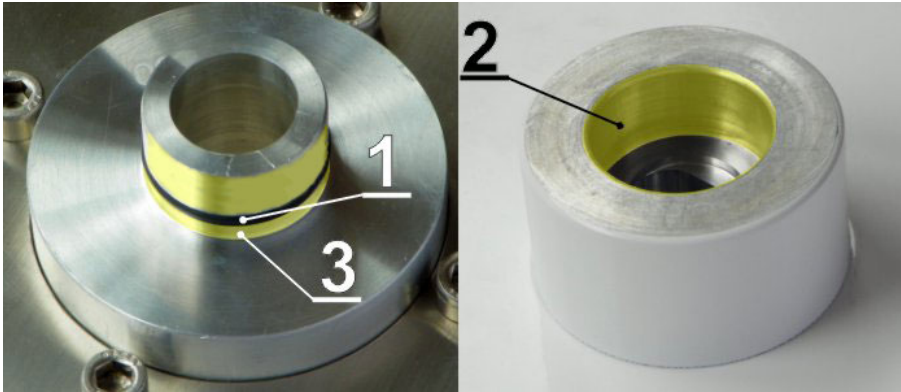

Fig. 5.28: Grease points on the antenna pivot and FOD unit bush

Grease the internal area of the bush on the FOD unit (2) and the "O" ring (1) with a thin even layer that allows the pin to slide easily into the bush without damaging the "O" ring. Grease the area beyond the "O" ring on the antenna pin (3) with a thicker layer so that it fills the gap caused by the play between the pin and the bush (max. 0.1 mm/ø) thus preventing moisture getting in. Installation should be carried out according to the antenna installation description – see point f of this description.

5.3. Connectors

5.3.1. Connecting the FOD communication unit to the user network

The FOD communication unit is connected to the user network by an Ethernet cable via interfaces GbE, IEEE802.3ac 1000BASE-T. As standard, RACOM recommends using an S/FTP CAT 7 cable and two RJ45 connectors for outdoor installations. One for the internal (IE-PS-RJ45-FH-BK) and the second for the external (plastic IE-PS-V01P-RJ45-FH or metallic IE-PS-V01M-RJ45-FH) end of the cable.

Based on the PoE standard the station is powered over the Ethernet cable.

If the station is equipped with two connectors, the right one carries user data, and the left connector is to be used for servicing.

The middle BNC type connector serves for connecting a voltmeter for precisely setting direction.



Fig. 5.29: Connecting the FOD communication unit



Important

Before connecting the FOD communication unit to the supply (to the user network) the FOD unit must be grounded according to Section 5.4, “Grounding”.

It is necessary to install the antenna lead so that there is no excessive mechanical stress applied on the Ethernet connector.

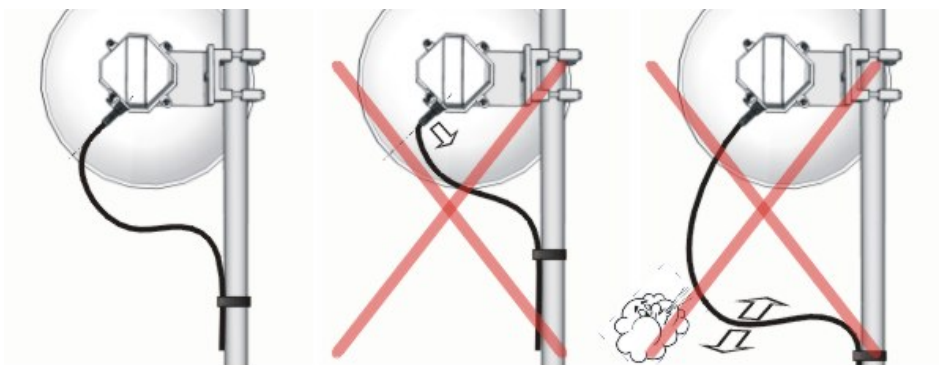

Fig. 5.30: Example of a correct lead installation.

5.3.2. Fitting an external IE-PS-V01P-RJ45-FH connector

We recommend using an S/FTP 4×(2×23AWG) Cat.7 + 2×(2×24 AWG) cable for connecting the FOD unit, as it is designed for external use. The cable contains two additional twisted pairs, 2x(2x24 AWG), which are not used. The following images show the internal cable without these additional pairs.

- a. Use the tools from the **RAy Tool** set for fitting connectors. See Section 3.7, “Accessories”.



Fig. 5.31: Tools for fitting connectors

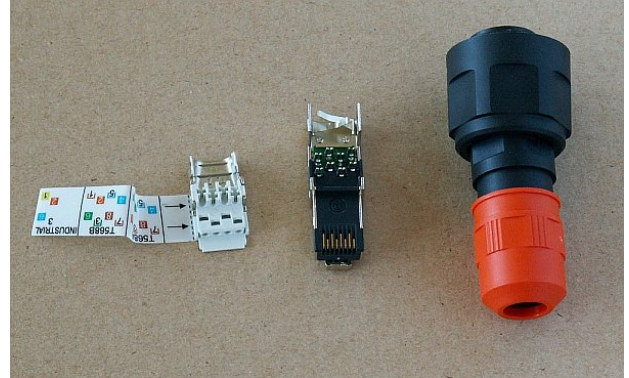

Fig. 5.32: IE-PI-RJ45-FH connector before fitting

- b. Undo the nut on the connector cover and push it on to the cable. Then trim at least 20 mm of insulation from the end of the cable.

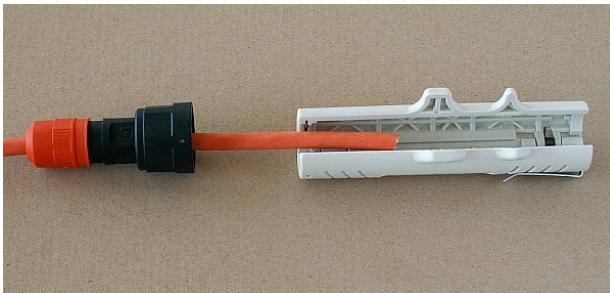

Fig. 5.33: Tool for removing insulation

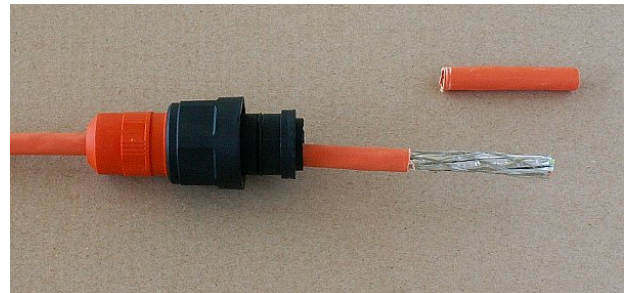

Fig. 5.34: Insulation removed

- c. Twist the braid forming the cable shielding together and wrap around the cable so that 2-3 loops are next to each other at the end of the insulation.

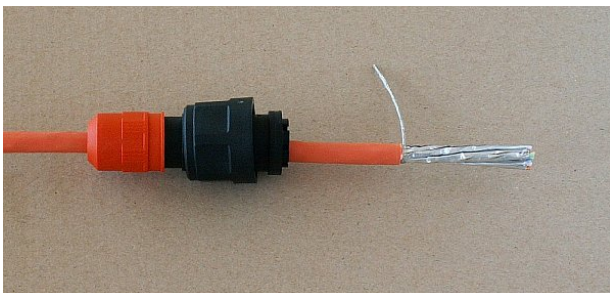

Fig. 5.35: Twisted shielding



Fig. 5.36: Shielding wrapped around the cable

- d. Separate individual pairs of conductors, remove the aluminium shielding from them, cut it off, and separate individual conductors. Cut off the two additional twisted pairs from the thinner wire in the middle (not seen on these images).

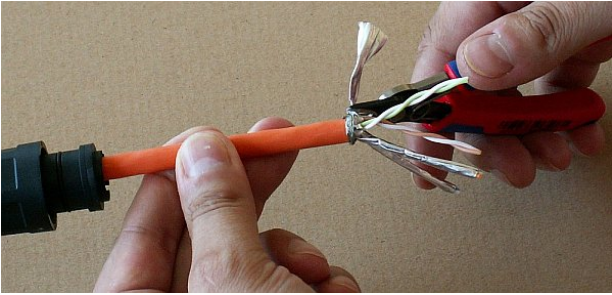

Fig. 5.37: Trimming shielding

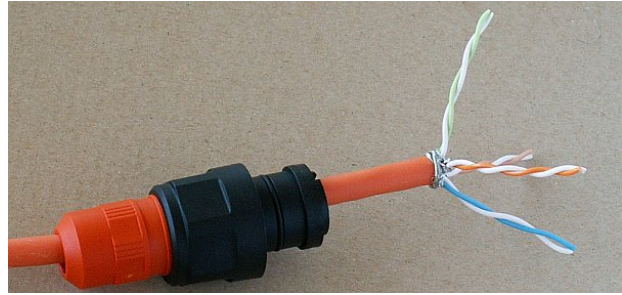

Fig. 5.38: Separated pairs of conductors

- e. Push the lower layer of conductors into the openings as per the pinout sticker (T568B) attached to the connector. Take care not to confuse white conductors from individual pairs.

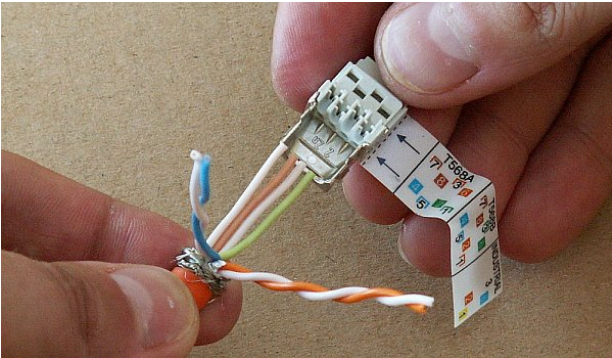

Fig. 5.39: Pushing the lower pairs into the connector

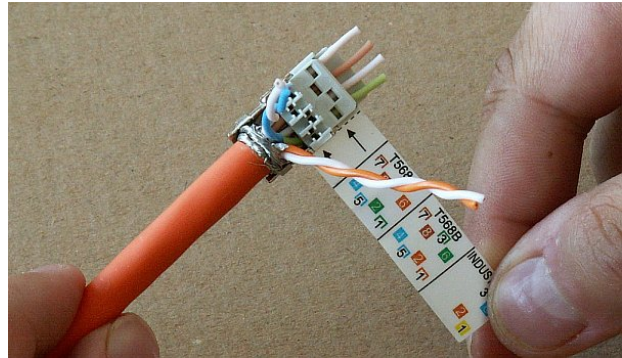

Fig. 5.40: Lower pairs pushed in

- f. Then from above push the upper conductors into the connector according to the pinout sticker and trim them. The cable must be pushed in far enough so that the braided shielding is inside the metal part of the connector.

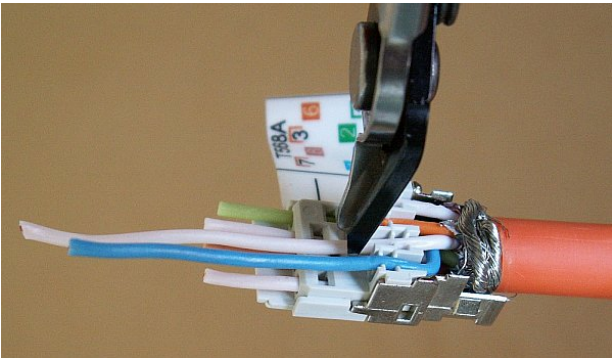

Fig. 5.41: Cutting off of the upper conductors

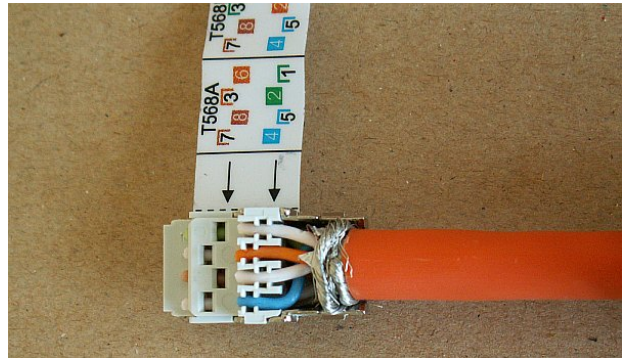

Fig. 5.42: All conductors in the connector

- g. Remove the pinout sticker and fit the complementary half of the connector. Squeeze the parts together until the locks snap into place. Use the pair of pliers with parallel jaws from the **RAY Tool** set for this. Standard pliers would damage the connector.

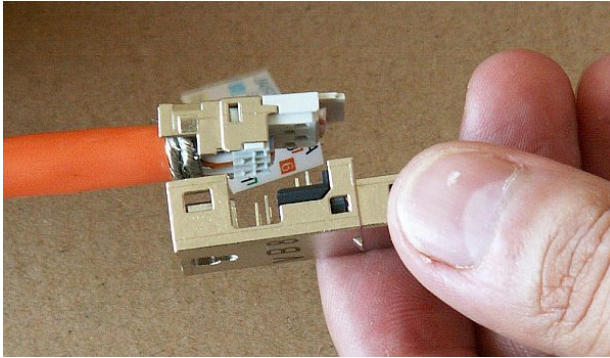

Fig. 5.43: Fitting the complementary half of the connector



Fig. 5.44: Squeezing the connector until the locks snap into place

- h. Then slide the protective cover onto the connector. It must fit into the grooves after snapping into place. Finally tighten the nut on the cover to seal the point where the cable enters the connector.



Fig. 5.45: Sliding the cover onto the connector



Fig. 5.46: Finished IE-PI-RJ45-FH connector

5.3.3. Fitting an internal IE-PS-RJ45-FH-BK connector

- a. Use the same tools as for fitting the external connector. The internal connector does not have a cover.

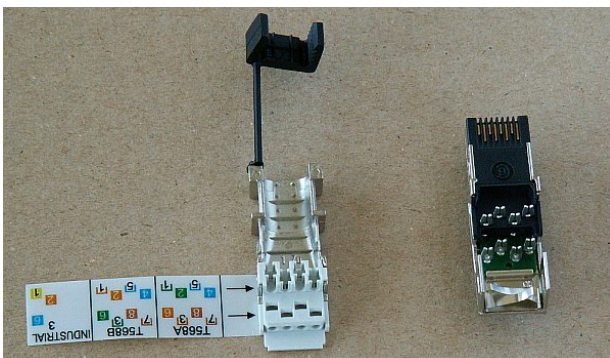

Fig. 5.47: IE-PS-RJ45-FH-BK connector before fitting

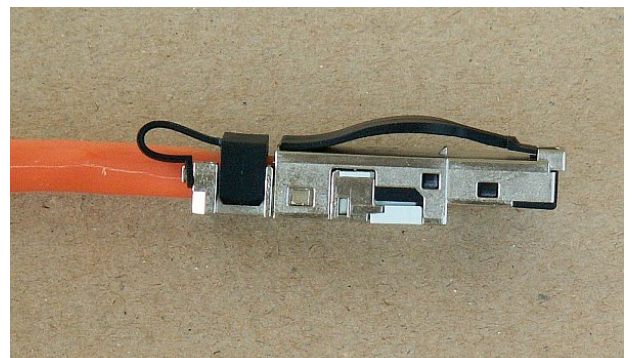

Fig. 5.48: Finished connector IE-PS-RJ45-FH-BK

- b. Trim at least 20 mm of insulation from the end of the cable.

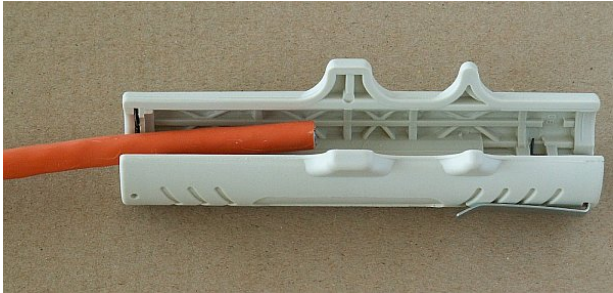

Fig. 5.49: Removing insulation



Fig. 5.50: Removed insulation

- c. Twist the braid forming the cable shielding together and wrap around the cable so that 2-3 loops are next to each other at the end of the insulation. Separate individual pairs of conductors, remove the aluminium shielding from them, cut it off, and separate individual conductors. Cut off the two additional twisted pairs from the thinner wire in the middle (not seen on these images).



Fig. 5.51: Twisted shielding

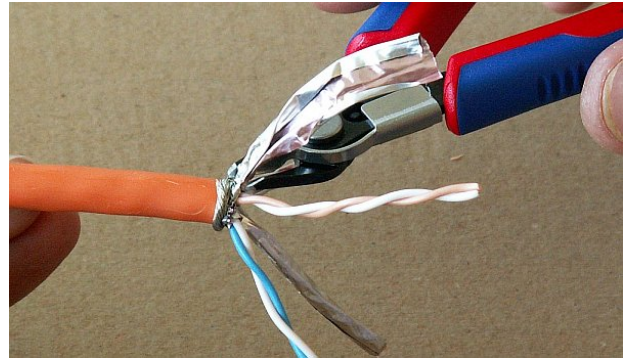

Fig. 5.52: Removing aluminium conductor shielding

- d. Prepare individual pairs according to the pinout sticker attached to the connector (T568B) and unwind the two pairs for the bottom part of the connector. Take care not to confuse white conductors from individual pairs.

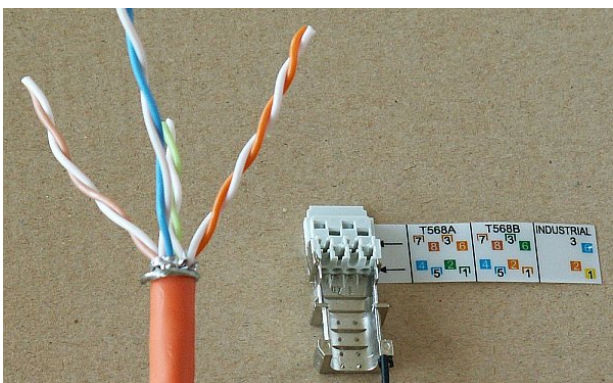

Fig. 5.53: Separated pairs of conductors

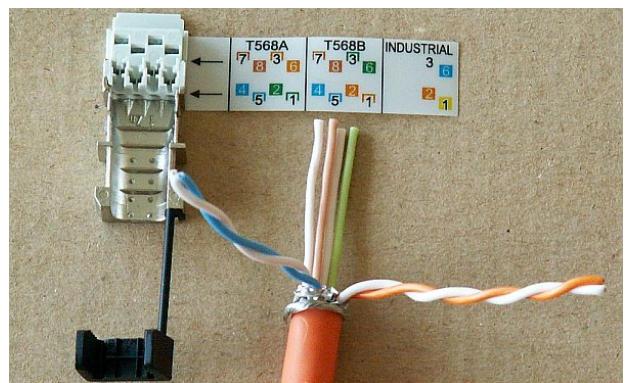

Fig. 5.54: Lower two pairs ready for inserting

- e. First insert the lower row of conductors from the back. Then unwind the others and insert them into the holes for the upper row of conductors, as per the pinout sticker. Ensure that the wrapped around shielding braid is inserted sufficiently to create a good contact with the second part of the connector fitted with sprung contacts. Snap the plastic clamp onto the cable. Squeeze it together tight enough so that it doesn't allow movement of the cable.

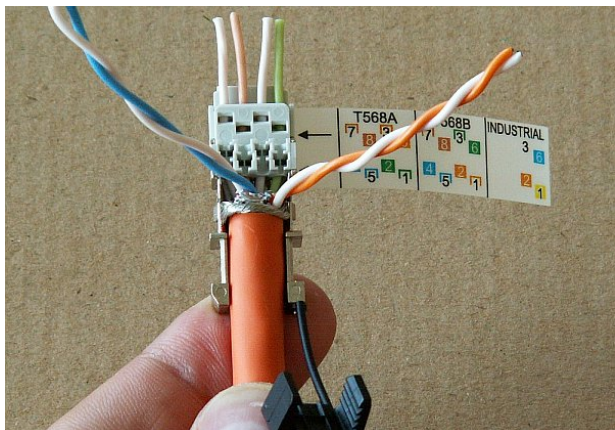

Fig. 5.55: Lower pairs pushed in

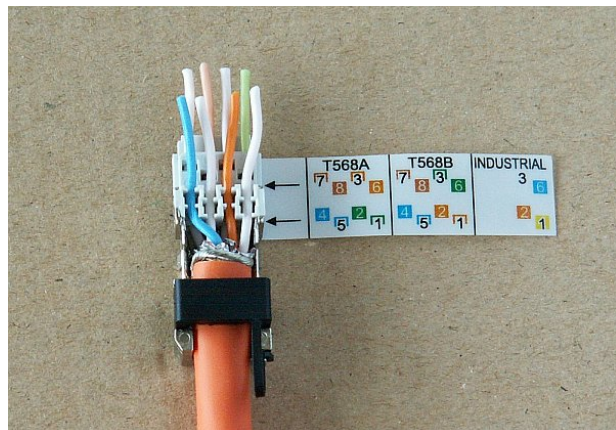

Fig. 5.56: All conductors in the connector

- f. Trim the overhanging conductors.

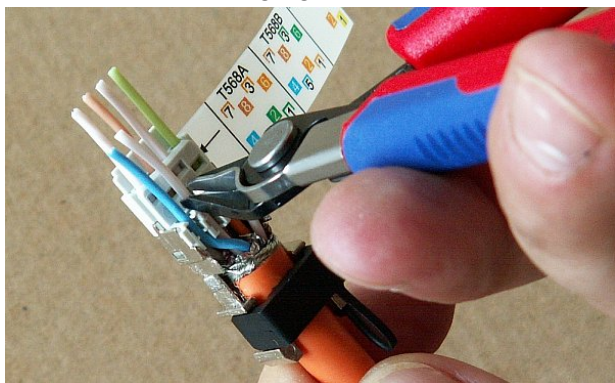

Fig. 5.57: Trimming conductors

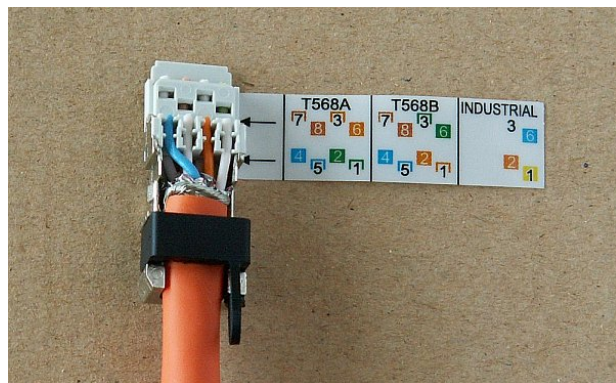

Fig. 5.58: Inserted and trimmed conductors

- g. Remove the pinout sticker from the connector and slide on the mate. Clamp the whole connector together until the locks snap into place. Use a pair of pliers with flat heads from the **RAY Tool** set. Ordinary pliers could damage the connector.

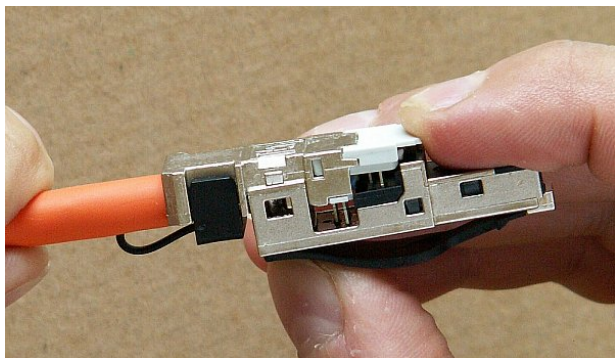

Fig. 5.59: Fitting the mate to the internal connector



Fig. 5.60: Clamping the internal connector together with pliers

5.4. Grounding

The lightning and overvoltage protection system example, designed in accordance with regulation CSN EN 62305.

1. Where possible the antenna should be located in an LPZ 0B protection zone with the use of a local or artificial air termination device for protection against direct lightning strikes.
2. When meeting conditions for ensuring electrical insulation (distance from the lightning conductor) in accordance with article 6.3, it is not recommended to ground the load-bearing structure and antenna to the external air termination network. Ground should be connected to the protective system of the internal LV wiring or grounded internal structures using a CYA 6 mm² bonding conductor, see Fig. 5.61, "Grounding installation 1"
3. If it is not possible to set up conditions of electrical insulation in accordance with article 6.3 we recommend connecting the load-bearing structure at roof level to the external air termination network via an 8mm diameter FeZn conductor and shielding the data cable before entry to the building with a grounding kit and CYA 6 mm² conductor to the bonding bus, and if not already set up then also to the external air termination network, see Fig. 5.62, "Grounding installation 2"
4. If there is not an external LPS on the building we recommend routing lightning current through an 8mm FeZn conductor to a common grounding system, or to a separate grounding electrode with a ground resistance up to 10 Ω.
5. For limiting the overvoltage transferred over the data cable and into the building we recommend fitting surge protection at the interface between zones LPZ 0 and LPZ 1 connected via a CYA 4 mm² conductor to the same grounding point as the antenna or the antenna mast.
6. We recommend protecting the PoE power supply from overvoltage on the LV side with suitable class D surge protection.

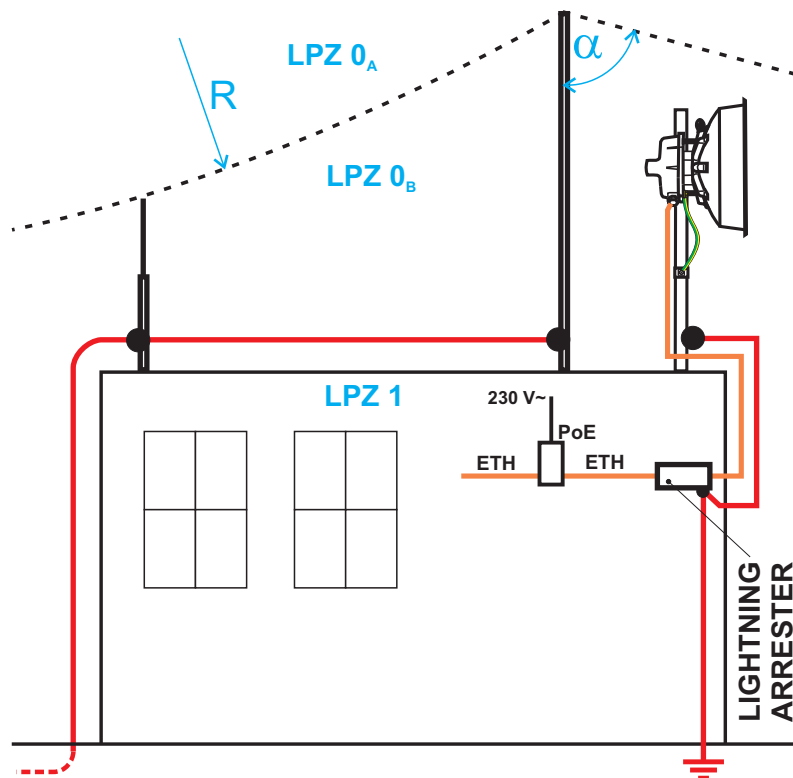

Fig. 5.61: Grounding installation 1

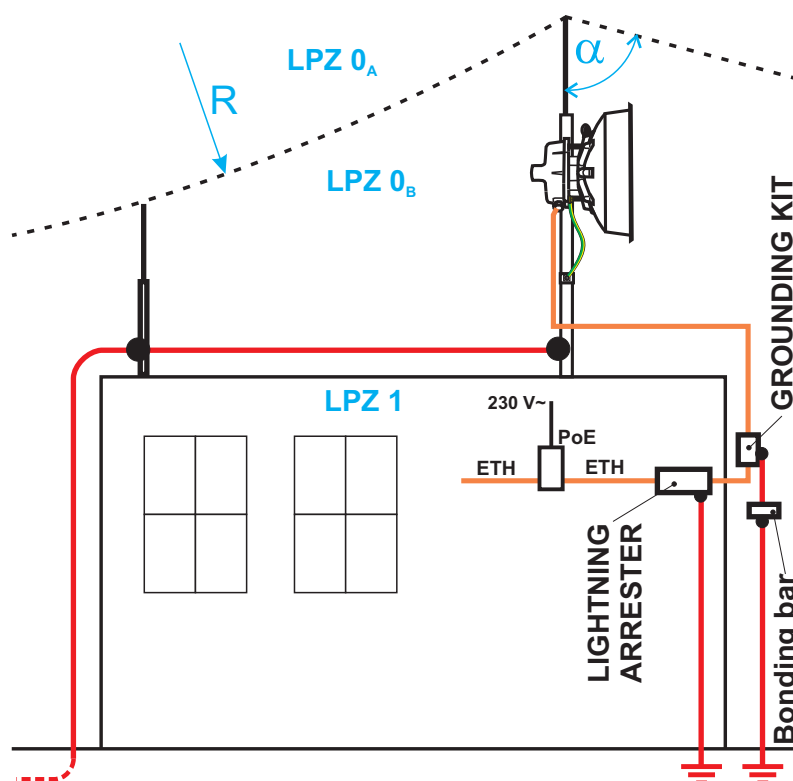

Fig. 5.62: Grounding installation 2

The RAY unit is grounded to the flange by the Ethernet connector using an M6 screw. An insulated copper cable with a minimum diameter of 6 mm^2 terminated with a terminal lug is used as a protective

conductor. The conductor should have a green/yellow sheath across its whole length. For grounding a RAY grounding kit can be ordered as an accessory (see Section 3.7, “Accessories”) containing a grounding terminal ZSA16, 40 cm grounding strip 15 mm wide, and 100 cm of cable with grounding lugs. For instructions on installing terminals see the datasheet RAY grounding kit¹. A qualified person must install the antenna.

Racom supplies surge protection for installation on Ethernet cables entering buildings. For more details see Surge protection².

Additional safety recommendations

- Only qualified personnel with authorisation to work at heights are entitled to install antennas on masts, roofs and walls of buildings.
- Do not install the antenna in the vicinity of electrical wiring. The antenna and bracket should not come into contact with electrical wiring at any time.
- The antenna and cables are electrical conductors. During installation electrostatic charges may build up which may lead to injury. During installation or repair work to parts of the antenna lead open metal parts must be temporarily grounded.
- The antenna and antenna cable must be grounded at all times. See Section 5.4, “Grounding”.
- Do not mount the antenna in windy or rainy conditions or during a storm, or if the area is covered with snow or ice.
- Do not touch the antenna, antenna brackets or conductors during a storm.



Fig. 5.63: Grounding kit for S/FTP 4+2 cable

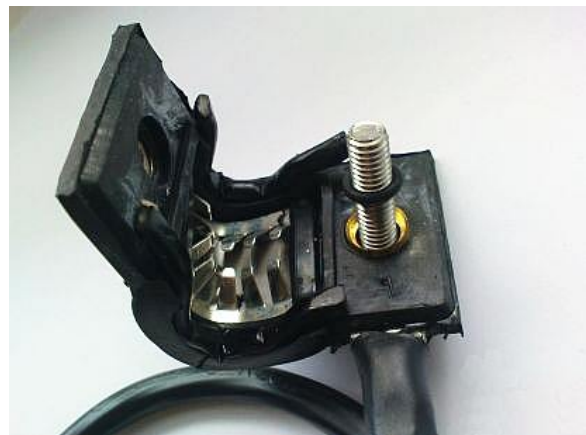

Fig. 5.64: Grounding kit detail

¹ http://www.racom.eu/download/hw/ray/free/eng/07_prislusenstvi/ZSA16-en.pdf

² <http://www.racom.eu/eng/products/microwave-link.html#accessories>

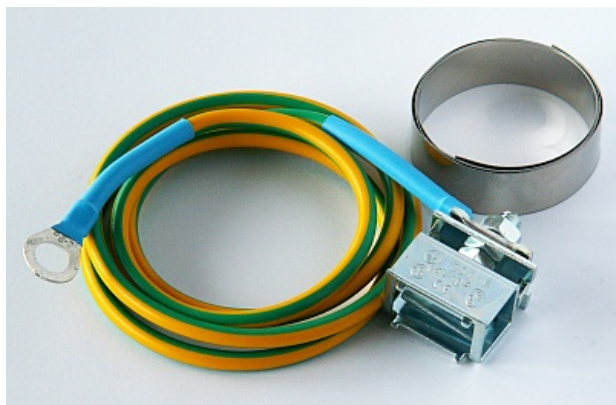

Fig. 5.65: RAY grounding kit



Fig. 5.66: Grounding the FOD unit



Fig. 5.67: Protective conductor at the FOD unit

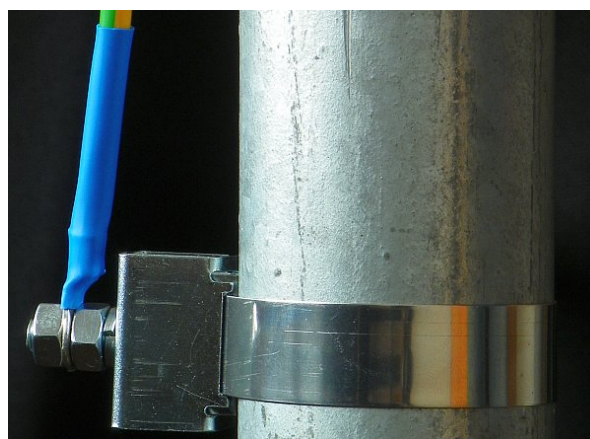

Fig. 5.68: Protective conductor at the mast on a ZSA16 terminal



Fig. 5.69: Separated lightning conductor

5.5. Start up

Connect a power supply to the installed FOD unit and connect the configuration PC. Use an internet browser (such as Mozilla Firefox) to enter the configuration menu.

5.5.1. Noise on the site

This chapter is particularly true for installation of links working in free bands, where the user has no secured frequency.

Analyse the level of noise in the individual channels using the spectrum analyzer under *Tools – Graphics – Frequency analyzer*. If necessary adjust the choice of working channel on the basis of the results.

While doing so respect the rule that in one location all units emit signal in the Upper part of the range and receive it in the Lower part of the range, or the other way round. A transmitter must not be installed in the part of the spectrum where other units function as receivers.

5.5.2. Antennas directing

If it is possible, use narrow channel, low modulation and high power for the first antenna directing. Working on both ends of the link simultaneously is favourable. Connect voltmeter to the BNC connector and observe RSS changes in 2 V DC range. Stronger signal corresponds to lower voltage. Alternate units on both sides and slowly adjust the antenna vertically and horizontally to find the position with

the strongest reception. At the same time look for the main signal maximums. To differentiate between the main and the side maximums refer to Main and side lobes paragraph.

RSS measurement

For correctly setting the bridge and positioning it in the right direction it is advisable to connect a PC and use the diagnostic capabilities of the RAY station. In uncomplicated cases it is enough to connect a voltmeter via a BNC connector and adjust to the lowest indicated voltage. Voltage is calibrated according to signal strength. E.g.:

RSS -65 dBm corresponds to voltage 0.65 V,

RSS -80 dBm corresponds to voltage 0.80 V etc.



Fig. 5.70: Connecting a voltmeter to the BNC connector.

Main and side lobes

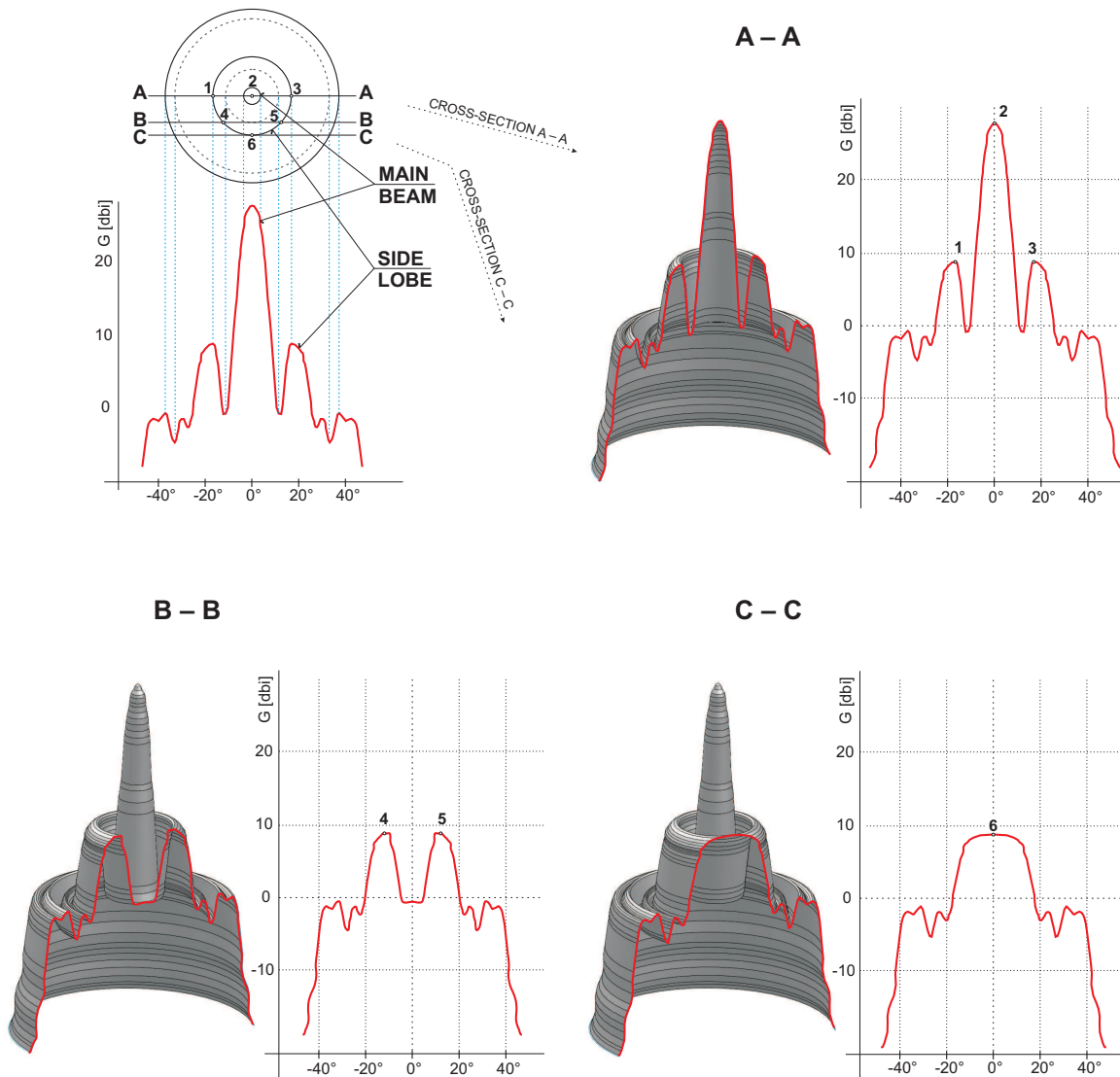

Fig. 5.71: Radiation diagrams

Both antennas should be oriented towards each other using the peaks of radiation diagram. Adjust the antenna alternately in the horizontal and vertical axes and monitor the resulting signal strength. Use the calculation of the expected RSS with the precision of several dBm as guidance. Side lobes transmit signal ca 20 dBm weaker, see the Microwave link Calculation³.

³ <http://www.racom.eu/eng/products/microwave-link.html#calculation>

The resulting RSS helps distinguish between the states A-A and C-C which appear similar. It also helps in situations where simple search for a maximum doesn't work as shown in the illustration "incorrect adjustment".

Real radiation diagrams are more complex, especially in that they run differently in horizontal and vertical axes. The basic steps for determining the main radiation lobe however stay valid. For example:

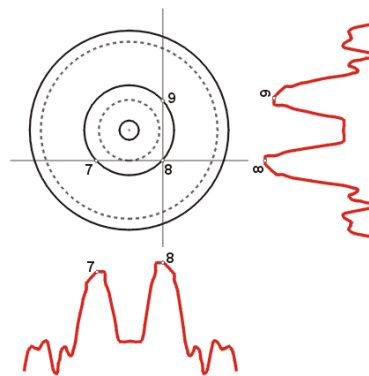

Fig. 5.72: Radiation diagram – incorrect adjustment

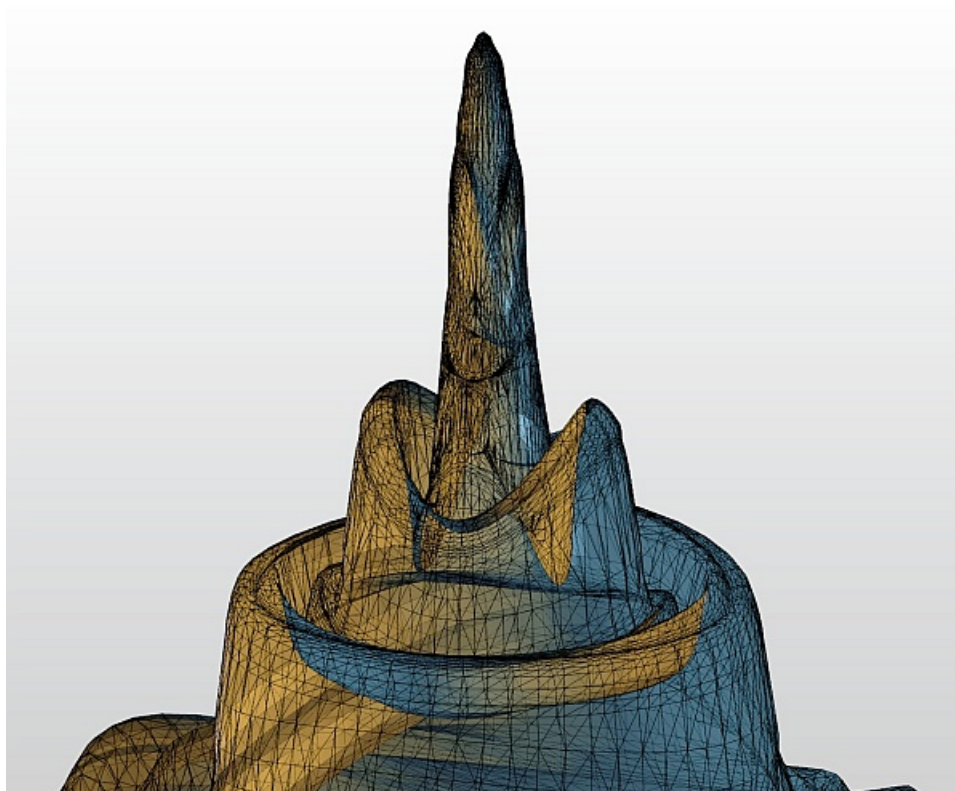

Fig. 5.73: 3D example of more complicated Radiation Pattern

5.5.3. Link test

Basic parameters of the link are shown in the menu *Status – Brief*, its quality is characterized by RSS and SNR. Values on Status screens can be refreshed manually by pressing the Refresh button or in real time with a period of several seconds after activating the Start button. Press the Stop button to terminate the periodic refresh of values.

The RSS, SNR and BER values can also be viewed on the screen *Tools – Graphics – Bar indicators*. After pressing the Start button, values will be refreshed with a period of one second.

After installation, it is good to reset the statistics using the Clear stats button in menu *Status – Detailed*. This allows easier diagnostics of the link's reliability over time.

5.5.4. Parameters setup

After both antennas have been directed, setup operation parameters for the link. In case of links operating in the free band, setup the parameters based on survey results from the tool *Tools – Graphics – Frequency analyser*. In case of links operating in licensed band, setup the parameters based on assigned license:

- Bandwidth
- Channel Selection (TX / RX channel)
- Modulation (TX modulation) – ACM is recommended. When selecting fixed modulation it is necessary to account for the fade margin. If fixed modulation is setup close to a possible maximum, then a deterioration in RSS could endanger the link both for data transfer as well as service access.
- Transmit power (RF power), or ATPC
- Verify and record IP addresses
- Define access channels – https / telnet / ssh / ssh with password

Restart both units by interrupting their power supply and verify the status of the link. This verifies that all parameters have been stored correctly in the memory.

Select *Tools – Maintenance – Backup – Settings – Backup - Download* and save the configuration to backup file "cnf_backup.tgz".

This completes the installation. Further configuration can be performed remotely.

6. Configuration

Controls

The following configuration buttons are used for configuration:

Apply	Apply and save parameters.
Cancel	Set parameters are overwritten with original values.
Refresh	Reload the current values of the station / both stations. Should the configuration be changed from other management session, the message <i>Info: Configuration changed, please click refresh</i> is displayed at the status bar (see screenshot lower). The <i>Refresh</i> button reloads valid data and refreshes web browser screen.
Load defaults	Load default values of the parameters on the screen. To use any of these values, you must use the <i>Apply</i> button.
Load custom	Loads values of individual parameters from backup configuration. To use any of these values, you must use the <i>Apply</i> button. For loading backup configuration see menu <i>Tools – Maintenance – Backup – Settings – Upload</i> .
Start	Use the <i>Start</i> button to start automatic refresh of displayed information. Information subject to this update are highlighted with a refresh icon.
Stop	Use the <i>Stop</i> button to stop automatic refresh of displayed information.

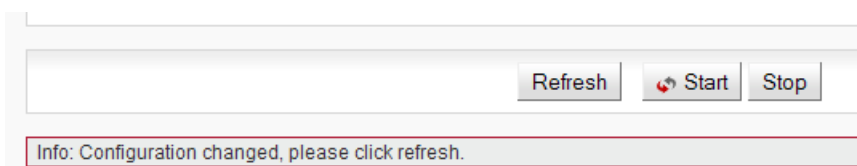

Fig. 6.1: Info Refresh

Help

The microwave link configuration system is equipped with built in Help - see Help section. The Help is accessible in two forms:

- Configuration parameter context help. The help text is displayed in the pop up window after clicking the parameter name.
- The whole user interface help. The help text is displayed within the configuration screen after clicking the *Help* menu.

Secure login

You can login into the configuration interface either using the **insecure http** protocol or the **secure https** protocol - by click to *go to secured version*. You can select the connection method on the login screen. If the https protocol is used, it is not possible to tap the network communication and acquire the station's login information.

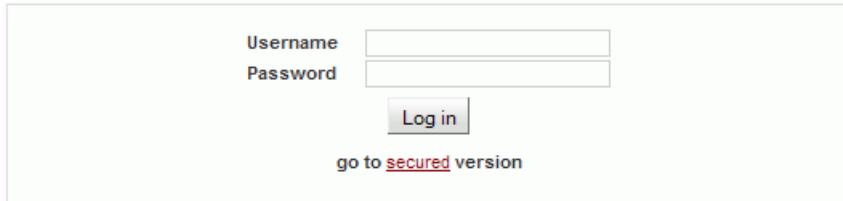

The image shows a login form with two input fields: 'Username' and 'Password'. Below the fields is a 'Log in' button. At the bottom of the form, there is a link that says 'go to [secured version](#)'.

Fig. 6.2: Login

Rollback function

If you interrupt the connection on an operating link by entering inappropriate radio link parameters, the original parameters will be restored after 1 minute. The connection is automatically restored.

6.1. Status bar

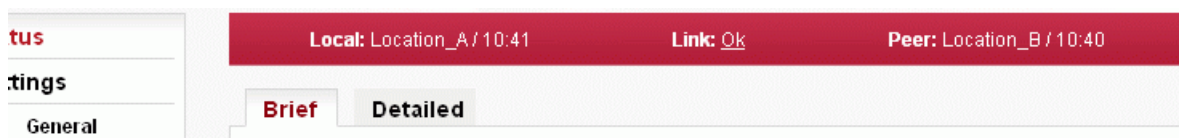

Fig. 6.3: Status bar 1

Status bar is located on the upper part of the screen below the title bar. It consists of 3 fields:

- Local station status (station, user is directly connected to via its management IP address).
- Local to Peer link status.
- Peer station status.

Local and Peer field displays:

- Station name according to configuration.
- Actual time valid for respective station.
- Warning or Alarm icon in case a warning or alarm occurs.

Link field displays:

- Status of the link between both sides of the station.
- Warning icon when the link is not capable of user data transfer.

Link status can be one of the following values:

UNKNOWN	Station start up. The initialization is not yet finished.
SETUP	Station initialization according to valid configuration.
SINGLE	Station in operation status. Link to peer station is not established.
CONNECTING	Connection to peer station in progress.
AUTHORIZING	Authorization of the peer station in progress.
OK	Link is connected. Peer station is authorized.
ANALYZER	Spectrum analyzer mode active. User data are not transferred.

All states, except the OK state, are highlighted by warning icon:

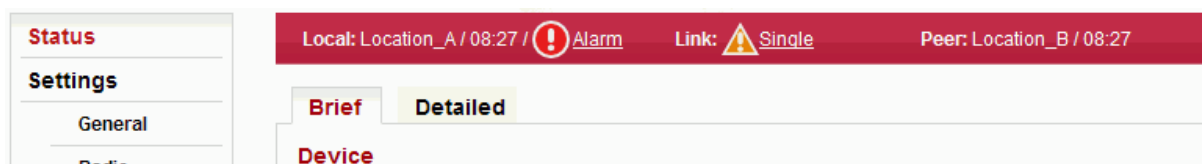

Fig. 6.4: Status bar 2

6.2. Status

Local: Location_A / 14:10
Link: Ok
Peer: Location_B / 14:10

Status

Settings

General

Radio

Ethernet

QoS

Service access

Alarm limits

Diagnostics

Graphs

Logs

Tools

Ping

Graphics

Maintenance

Help

Brief
Detailed

Device

	Local	Peer
Unit code	RAY17	RAY17
Station name	Location_A	Location_B
Inside temperature [°C]	55.5	57.0
Voltage [V]	56.2	56.5

Radio

	Local	Peer
Bandwidth [MHz]	28 MHz	28 MHz
TX channel [GHz]	L4 17.11400	U29 17.20150
RX channel [GHz]	U29 17.20150	L4 17.11400
TX modulation	QAM256 ACM / QAM256	QAM128 ACM / QAM256
TX power [dBm]	-15	-18
RSS [dBm]	-63.5	-60.0
SNR [dB]	30.1	31.8
BER [-]	0.00e+00	0.00e+00

Ethernet

	Local	Peer
Ethernet link mode	1000Base-T/FD	1000Base-T/FD

Service access

	Local	Peer
IPv4 address	192.168.141.226/24	192.168.141.227/24
Services	HTTP(S), SSH	HTTP(S), SSH
Management VLAN	off	off

Refresh
 Start
Stop

Fig. 6.5: Menu Status

Menu *Status – Brief* and *Status – Detailed* contains basic information about local and remote (Peer) station. Information is refreshed manually by pressing the Refresh button, or automatically after pressing the Start button.

Status – Brief shows only the most important values. *Status – Detailed* provides further details. Below is a list of all values - according to the menu *Status – Detailed*.

6.2.1. Status – Device

The *Device* menu provides basic information about local and remote station. Informations are valid at the moment the page is open, or the *Refresh* button is pushed.

- Unit code** Station type indicator.
- Serial no.** Station serial number.
- Station name** Station name selected by user.
- Station location** Unit location assigned by user.

Firmware version	Station's firmware version.
Date, Time	The internal real-time clock. The clock is set manually or it is synchronized with NTP server and set for both stations.
Inside temperature [°C]	Temperature inside the station.
Voltage [V]	Station's power supply voltage level.

6.2.2. Status – Radio

Radio type	Radio unit type: L (Lower) or U (Upper) part of the frequency band.
Polarization	Horizontal or vertical polarization based on the physical installation. Indicates the polarization of received signal. Local and Peer are indicated separately. The proper position of the cable is sideways down. Notice for ISM connections (RAy17, RAY24): One side of the link must be installed in vertical polarization and the other in the horizontal polarization.
Frequency table	Displays the currently selected frequency table.
Bandwidth [MHz]	Nominal width of the channel. Both units in a link have to use the same bandwidth.
TX channel [GHz] RX channel [GHz]	Used channels. Both number of the channel and frequency in GHz are listed.
TX modulation	Modulation type currently used for transmitting. When adaptive modulation is enabled, the ACM letters are displayed as well as information about maximum permitted modulation: "current modulation ACM / maximum modulation"
TX power [dBm]	Current output power on the RF channel in dBm. If ATPC is enabled, the ATPC letters are displayed as well as information about maximum permitted power: "current power ATPC / maximum power"
Net bitrate [Mbps]	Current transfer capacity of radio channel for user data.
Max. net bitrate [Mbps]	The maximum RF channel capacity according to installed feature key.
RSS [dBm]	Received signal strength. If ATPC is enabled, the ATPC letters are displayed as well as information about threshold value for activation of power control loop: "current RSS ATPC / threshold RSS"
SNR [dB]	Signal to Noise Ratio. If ATPC is enabled, the ATPC letters are displayed as well as information about threshold value for activation of power control loop: "current SNR ATPC / threshold SNR"
BER [-]	Bit Error Rate registered at the receiving end. Instantaneous value.
Link uptime	Time elapsed since the current link connection has been established.

6.2.3. Status – Ethernet

Ethernet link mode	Status of ethernet interface. Current bit rate (10 = 10BASE-T, 100 = 100BASE-TX and 1000 = 1000BASE-T) and state of duplex (FD = full duplex, HD = half duplex).
MDIX	Status of the internal crossover of ethernet cables. (MDIX = internally crossed pairs, MDI = direct connection, N/A means an unknown state).
Storm control	Switch blocking protection status.
QoS	Switch Quality of Service status.

6.2.4. Status – Service access

MAC address	HW address of the ethernet module.
IPv4 address	IP address in the standard dotted decimal notation, including the bit width of netmask after the forward slash.
Services	Services enabled for station management and monitoring (HTTPS, SSH, Telnet SNMP, NTP).
Management VLAN	Service access via VLAN management only.

6.2.5. Status – Statistics

Detailed traffic statistics in the user interface.

In All Packets	Number of all received packets.
In Unicast Packets	Counter of unicast packets received.
In Multicast Packets	Counter of multicast packets received.
In Broadcast Packets	Counter of broadcast packets received.
In All Errors	Counter of all packet errors (including dropped).
In Dropped Packets	Counter of received packets, dropped.
In Crc Errors	Counter of corrupted packets (CRC error) received. Usually indicates a problem on Eth cable or connector.
Out All Packets	Number of all outgoing packets.
Out Unicast Packets	Counter of outgoing unicast packets.
Out Multicast Packets	Counter of outgoing multicast packets.
Out Broadcast Packets	Counter of outgoing broadcast packets.
Out All Errors	Number of outgoing packet errors.
Out Dropped Packets	Counter of dropped outgoing packets.
Out Collision Packets	Counter of detected collisions in transmission.

Information on statistical data

Statistics cleared	Time of log clearing.
Statistics period	Period of log refresh.

Radio link statistics

Overall Link Uptime	Overall time the link has been connected.
Overall Link Downtime	Overall time the link has been disconnected.
Reliability [%]	The ratio of "Uptime" and "Downtime".
Current Link Uptime	Current time the link has been connected.
The Longest Drop	The longest downtime period recorded.
The Last Drop	Length of the last link interruption.
No of Drops	Number of link interruptions.

6.3. Settings

6.3.1. Settings – General

Status	Local: Location_A / 12:43	Link: Ok	Peer: Location_B / 12:43																																										
Settings	General																																												
<ul style="list-style-type: none"> > General Radio Ethernet QoS Service access Alarm limits 																																													
Diagnostics																																													
<ul style="list-style-type: none"> Graphs Logs 																																													
Tools																																													
<ul style="list-style-type: none"> Ping Graphics Maintenance 																																													
Help																																													
	<table border="1"> <thead> <tr> <th></th> <th>Local</th> <th>Peer</th> </tr> </thead> <tbody> <tr> <td>Unit code</td> <td>RAY17</td> <td>RAY17</td> </tr> <tr> <td>Serial no.</td> <td>28282</td> <td>80808</td> </tr> <tr> <td>Station name</td> <td><input type="text" value="Location_A"/></td> <td><input type="text" value="Location_B"/></td> </tr> <tr> <td>Station location</td> <td><input type="text" value="Rokytno"/></td> <td><input type="text" value="Pohledec"/></td> </tr> <tr> <td>LED indicators</td> <td><input checked="" type="checkbox"/></td> <td><input checked="" type="checkbox"/></td> </tr> <tr> <td>Date</td> <td>2013-04-19</td> <td>2013-04-19</td> </tr> <tr> <td>Time</td> <td>12:43:42</td> <td>12:43:39</td> </tr> <tr> <td>Time source</td> <td><input type="text" value="manual"/></td> <td><input type="text" value="manual"/></td> </tr> <tr> <td>Adjust time</td> <td colspan="2"><input type="button" value="Adjust time"/></td> </tr> <tr> <td>NTP source IP</td> <td><input type="text" value="0.0.0.0"/></td> <td><input type="text" value="0.0.0.0"/></td> </tr> <tr> <td>NTP period</td> <td><input type="text" value="1 m"/></td> <td><input type="text" value="1 m"/></td> </tr> <tr> <td>Time zone</td> <td colspan="2"><input type="text" value="(GMT) Greenwich Mean Time"/></td> </tr> <tr> <td>Daylight saving</td> <td><input type="text" value="off"/></td> <td><input type="text" value="off"/></td> </tr> </tbody> </table>		Local	Peer	Unit code	RAY17	RAY17	Serial no.	28282	80808	Station name	<input type="text" value="Location_A"/>	<input type="text" value="Location_B"/>	Station location	<input type="text" value="Rokytno"/>	<input type="text" value="Pohledec"/>	LED indicators	<input checked="" type="checkbox"/>	<input checked="" type="checkbox"/>	Date	2013-04-19	2013-04-19	Time	12:43:42	12:43:39	Time source	<input type="text" value="manual"/>	<input type="text" value="manual"/>	Adjust time	<input type="button" value="Adjust time"/>		NTP source IP	<input type="text" value="0.0.0.0"/>	<input type="text" value="0.0.0.0"/>	NTP period	<input type="text" value="1 m"/>	<input type="text" value="1 m"/>	Time zone	<input type="text" value="(GMT) Greenwich Mean Time"/>		Daylight saving	<input type="text" value="off"/>	<input type="text" value="off"/>		
	Local	Peer																																											
Unit code	RAY17	RAY17																																											
Serial no.	28282	80808																																											
Station name	<input type="text" value="Location_A"/>	<input type="text" value="Location_B"/>																																											
Station location	<input type="text" value="Rokytno"/>	<input type="text" value="Pohledec"/>																																											
LED indicators	<input checked="" type="checkbox"/>	<input checked="" type="checkbox"/>																																											
Date	2013-04-19	2013-04-19																																											
Time	12:43:42	12:43:39																																											
Time source	<input type="text" value="manual"/>	<input type="text" value="manual"/>																																											
Adjust time	<input type="button" value="Adjust time"/>																																												
NTP source IP	<input type="text" value="0.0.0.0"/>	<input type="text" value="0.0.0.0"/>																																											
NTP period	<input type="text" value="1 m"/>	<input type="text" value="1 m"/>																																											
Time zone	<input type="text" value="(GMT) Greenwich Mean Time"/>																																												
Daylight saving	<input type="text" value="off"/>	<input type="text" value="off"/>																																											

Fig. 6.6: Menu Settings – General

Setup of general parameters of the link.

Unit code	Station type indicator.
Serial no.	Station serial number.
Station name	Station name selected by user.
Station location	Unit location assigned by user.
LED indicators	Enable LED status indicators on the body of the station. You can turn off all LEDs with this option.
Date, Time	The internal real-time clock. The clock is set manually or it is synchronized with NTP server and set for both stations.
Time source	Time synchronization source setup. Manual setup or NTP protocol use. For easier diagnostics of link operation, it is recommended to use the NTP time synchronization.

Adjust time

Manual time setup. Use the dialog box to manually set the current date and time. You can copy time from browser (local PC).

NTP source IP

IP address of the time synchronization server.

NTP period

Time synchronization interval.

Time zone

Time zone

Daylight saving

Enable daylight saving time



Note

When the time zone and/or daylight saving time is changed, the original values set in the RAY unit are kept. The actual change takes place after OS restart in order to prevent unexpected states related with local time change.

6.3.2. Settings – Radio

	Local	Peer
Radio type	L	U
Polarization	horizontal	vertical
Bandwidth [MHz]	28 MHz	28 MHz
TX channel [GHz]	L4 17.11400	U29 17.20150
RX channel [GHz]	U29 17.20150	L4 17.11400
Duplex spacing [MHz]	87.500	
ACM	<input checked="" type="checkbox"/>	<input checked="" type="checkbox"/>
TX modulation	QAM128	QAM256
ATPC	<input type="checkbox"/>	<input type="checkbox"/>
TX power [dBm]	-20	-15
Antenna gain [dBi]	8.00	10.00
EIRP ?= limit [dBm]	-12.00 <= 20.00	-5.00 <= 20.00

Fig. 6.7: Configuration menu Settings – Radio

Setup of general parameters of the radio link.

Radio type

Information about the type of radio unit: L(ower) or U(pper) band.

Polarization	Horizontal or vertical polarization based on the physical installation. Indicates the polarization of received signal. Local and Peer are indicated separately. The proper position of the cable is sideways down. Notice for ISM connections (RAy17, RAY24): One side of the link must be installed in vertical polarization and the other in the horizontal polarization.
Bandwidth [MHz]	One of standard channel widths can be selected. This parameter must be set identically in local and remote.
TX channel [GHz] RX channel [GHz]	TX and RX channels are selected from a list of channels. The basic configuration has the TX and RX options interconnected. In this case the basic duplex spacing between channels is preserved and by selecting one channel, the other three are defined as well. For stations operating in free bands, it is possible to disconnect the TX-RX lock and select TX and RX channels individually. Corresponding channels at peer station are set automatically. <i>Notice</i> – Non-standard duplex setting leads to non-effective use of the spectrum.
Duplex spacing [MHz]	Information about duplex spacing of TX and RX channel.
ACM	Enable automatic control of modulation.
TX modulation	Modulation level for TX channel. You can select in range from QPSK (high sensitivity for difficult conditions) to 256QAM (high speed under appropriate conditions). In case of enabled ACM it has the meaning of the maximum (highest) allowed modulation.
ATPC	Enable automatic control of RF power. Power is regulated towards lower values while maintaining highest modulation level. Maximum output power is limited by Tx power parameter. The power control loop is primarily controlled by RSS. The SNR value is taken into account as well, because the situation of high interference value can lead to high RSS but low SNR.
TX power [dBm]	Desired output RF power. In case of enabled ATPC it has the meaning of the maximum allowed power.
Antenna gain [dBi]	Only for links operating in the ISM band (RAy17, RAY24). Gain of used antenna. It is used to calculate approximate EIRP.
EIRP ?= limit [dBm]	Only for links operating in the ISM band (RAy17, RAY24). Approximate calculation of EIRP. Number on the right shows the allowed EIRP limit. Sign between numbers gives information on compliance/non-compliance with allowed EIRP limits.

6.3.3. Settings – Ethernet

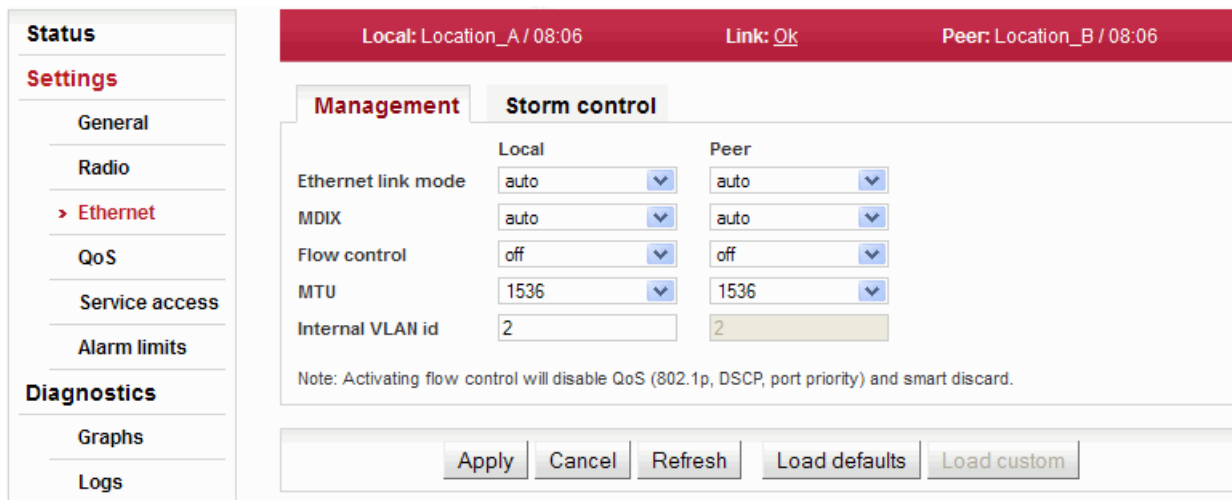

Fig. 6.8: Configuration menu Settings – Ethernet

Management

Ethernet interface physical layer parameters setup.

Ethernet link mode	Switching between transfer speed and flow control automatic negotiation or manual setting.
MDIX	Media Dependent Interface Crossover enables working with both types of ethernet cables, straight-through and crossover. The default option "auto" switches on automatic detection and performs an internal crossover if necessary.
Flow control	Mechanism for temporarily stopping the transmission of data on an ethernet network. Enabling flow control allows use of buffers of connected active network elements for levelling uneven flow of user data. If flow control is enabled, you cannot use the built-in QoS functions. For correct operation it is necessary to also enable Flow control on the connected device.
MTU	Setup of maximum allowed length of Ethernet frame. If transfer of tagged frames is not needed, you can choose smaller MTU. If you select smaller MTU, more storage space is available for QoS.
Internal VLAN id	The RAY unit uses one VLAN id for internal needs. It can be changed if there is a conflict with user data.

Storm control

Protection against packet flooding and subsequent device input switch blocking:

Broadcast	traffic directed to broadcast address (DA=FFFFFFFFFFFFH)
Multicast	traffic directed to multicast addresses (DA[40]=1B)
Un-learned unicast	un-learned unicast traffic
100Mb/1Gb 10Mb threshold [pkts/50ms]	Setting the threshold to activate protection. Set as number of packets per 50ms. Set separately for 10Mb link speed, or for 100Mb and 1Gb link speeds.

6.3.4. Settings – QoS

The Quality of Service (QoS) menu groups together multiple options of manipulating user data flow.

Ingress policing

Fig. 6.9: Configuration menu Settings – QoS

Ingress policing – causes user data flow to be limited to certain value. The excessive packets are discarded.

Ingress policing Enable Ingress policing. Applies to the device user port.

Speed [Mbps] Data rate to limit the Ethernet traffic to. If this speed is exceeded, Flow control is initiated. If packets are still incoming, they are dropped.

Mode Ingress policer operation mode:

- **soft** – Flow control is activated at low fill of input buffer. Good to use if the connected device has Flow control enabled and has a large buffer.
- **default** – Universal settings. Close to “hard” settings, but with Flow control enabled at connected device, packet loss is not possible.
- **hard** – Flow control is activated only after the input buffer is completely full. Good to use if the connected device has a small buffer.



Warning

The Ingress policing activation deactivates the switch QoS functions.

802.1p

Local: Location_A / 12:52 Link: Ok Peer: Location_B / 12:52

Ingress policing **802.1p** **DSCP** **TCP / UDP ports** **Queue management**

	Local	Peer
802.1p	<input checked="" type="checkbox"/>	<input checked="" type="checkbox"/>
Prefer DSCP	<input type="checkbox"/>	<input type="checkbox"/>
Class of service		
0	0	0
1	0	0
2	1	1
3	1	1
4	2	2
5	2	2
6	3	3
7	3	3

Note: Activating QoS will disable flow control and ingress policing.

Apply Cancel Refresh Load defaults Load custom

Fig. 6.10: Configuration menu Settings – QoS – 802.1p

Setup of QoS controlled by priority bits according to IEEE 802.1p.

802.1p Enabling QoS according to 802.1p

Prefer DSCP If priority control is enabled according to DSCP and incoming packet is coloured both by 802.1p priority and by DSCP – prioritization is governed (when enabling this option) by the DSCP rules.

Class of service 0..7 Arranging individual priorities (coded in priority bits according to IEEE 802.1p) into selected output queue (0..3).



Warning

The QoS activation deactivates the Flow control and Ingress policing.

DSCP

Local: Location_A / 12:53
Link: [Ok](#)
Peer: Location_B / 12:53

Status

Settings

General

Radio

Ethernet

> QoS

Service access

Alarm limits

Diagnostics

Graphs

Logs

Tools

Ping

Graphics

Maintenance

Help

Ingress policing
802.1p
DSCP
TCP / UDP ports
Queue management

Local
Peer

DSCP

DSCP	Local	Peer	DSCP	Local	Peer	DSCP	Local	Peer	DSCP	Local	Peer
0	0	0	16	1	1	32	2	2	48	3	3
1	0	0	17	1	1	33	2	2	49	3	3
2	0	0	18	1	1	34	2	2	50	3	3
3	0	0	19	1	1	35	2	2	51	3	3
4	0	0	20	1	1	36	2	2	52	3	3
5	0	0	21	1	1	37	2	2	53	3	3
6	0	0	22	1	1	38	2	2	54	3	3
7	0	0	23	1	1	39	2	2	55	3	3
8	0	0	24	1	1	40	2	2	56	3	3
9	0	0	25	1	1	41	2	2	57	3	3
10	0	0	26	1	1	42	2	2	58	3	3
11	0	0	27	1	1	43	2	2	59	3	3
12	0	0	28	1	1	44	2	2	60	3	3
13	0	0	29	1	1	45	2	2	61	3	3
14	0	0	30	1	1	46	2	2	62	3	3
15	0	0	31	1	1	47	2	2	63	3	3

Note: Activating QoS will disable flow control and ingress policing.

Apply
Cancel
Refresh
Load defaults
Load custom

Fig. 6.11: Configuration menu Settings – QoS – DSCP

Setting of QoS governed by DSCP priority bits (Differentiated Services, or DiffServ) in the IP header.

DSCP Enabling QoS according to DSCP

DSCP 0..63 Arranging individual priorities (coded in DS field of IP header) into selected output queue (0..3).

**Warning**

The QoS activation deactivates the Flow control and Ingress policing.

TCP/UDP ports

Fig. 6.12: Configuration menu Settings – QoS – TCP/UDP ports

Setting of QoS governed by number or range of TCP/UDP ports.

TCP/UDP ports Enabling QoS according to TCP/UDP ports.

Prefer DSCP If priority control is enabled according to DSCP and incoming packet is coloured both by DSCP priority and matches one of the rules listed here – prioritization is governed (with this option enabled) by the DSCP rules.

Stream 0..7 Up to 8 ranges of TCP/UDP ports can be configured. The range applies to both protocols: TCP and UDP.

- **From** – Start of TCP/UDP ports range.
- **To** – End of TCP/UDP ports range. If we want to prioritize only one port, use same values for “From” and “To”. The range of TCP/UDP ports can be up to 255.
- **Side** – Defines whether it is a source or destination TCP/UDP port(s).
- **Queue** – The target output queue for packets matching the rule.



Warning

The QoS activation deactivates the Flow control and Ingress policing.

Queue management

Local: Location_A / 13:42
Link: [Ok](#)
Peer: Location_B / 13:42

Status

Settings

General

Radio

Ethernet

> **QoS**

Service access

Alarm limits

Diagnostics

Graphs

Logs

Tools

Ping

Graphics

Maintenance

Help

Ingress policing
802.1p
DSCP
TCP / UDP ports
Queue management

Queue mode

	Local		Peer	
	Strict	WFQ	Strict	WFQ
Mode	<input checked="" type="checkbox"/>	<input type="checkbox"/>	<input type="checkbox"/>	<input checked="" type="checkbox"/>
Ratio Mode				<input checked="" type="checkbox"/>

Queue	Bitrate [Mbps]		Bitrate [Mbps]	
0	<input type="text" value="400"/>	<input type="text" value="1"/>	<input type="text" value="400"/>	<input type="text" value="2"/>
1	<input type="text" value="100"/>	<input type="text" value="1"/>	<input type="text" value="400"/>	<input type="text" value="1"/>
2	<input type="text" value="50"/>	<input type="text" value="1"/>	<input type="text" value="400"/>	<input type="text" value="1"/>
3	<input type="text" value="100"/>	<input type="text" value="1"/>	<input type="text" value="400"/>	<input type="text" value="1"/>

Smart discard

Queue	Local	Peer
0	<input type="text" value="Mode 0 (0/0)"/> <input type="button" value="v"/>	<input type="text" value="Mode 0 (0/0)"/> <input type="button" value="v"/>
1	<input type="text" value="Mode 1 (0/25)"/> <input type="button" value="v"/>	<input type="text" value="Mode 0 (0/0)"/> <input type="button" value="v"/>
2	<input type="text" value="Mode 0 (0/0)"/> <input type="button" value="v"/>	<input type="text" value="Mode 0 (0/0)"/> <input type="button" value="v"/>
3	<input type="text" value="Mode 0 (0/0)"/> <input type="button" value="v"/>	<input type="text" value="Mode 0 (0/0)"/> <input type="button" value="v"/>

Note: For enabling queue management mode activate at least one QoS rule (802.1p, DSCP, port priority).
Note: Activating smart discard will disable flow control.

Fig. 6.13: Configuration menu Settings – QoS – Queue management

Setting the operation mode of output queues. These are internal switch queues for organization of packets based on individual QoS rules.

**Note**

To enable configuring output queues, you must enable at least one of the QoS rules.

Mode

Regime for sending out packets from individual queues.

- **Strict** – If there are packets in a high priority queue, packets from that queue are sent out. Only after this queue is completely empty, packets from a lower priority queue are sent out.
- **WFQ** – Weighted Fair Queuing. Packets from individual queues are sent out according to set ratios (see below).

Ratio Mode

Turns on the WFQ regime sending out ratio.

Queue 0..3

Setting parameters (ratios) of packets sending out for individual queues.

- **Strict column** – Maximum output speed [Mbps] for individual queues. Allowed range 0 .. 400 [Mbps]
- **WFQ Column** – Packet sending out ratios for individual queues. Higher values means more frequent sending out from the given queue.

Smart discard

Setting mode for packet dropping in case of insufficient output channel capacity. Packets are dropped with certain probability before the queue is filled completely. For example, this mechanism prevents blocking of high priority packets by low priority packets. The “early random discard” mechanism is proving to be useful particularly for TCP traffic.

Smart discard mode can be used independently of QoS. To ensure correct function of *Smart discard* (i.e. Mode 1..3) *Flow control* is off.

Queue 0..3 Setting drop mode for individual output queues

- Mode 0 (0/0) – Packets are dropped only after output queue is fully congested. Smart discard mode is therefore turned off.
- Mode 1 (0/25) – When the queue is full to 3/4, packets will be dropped with 25% probability.
- Mode 2 (25/50) – When the queue is full to 2/3, packets will be dropped with 25% probability. When the queue is full to 3/4, packets will be dropped with 50% probability.
- Mode 3 (50/75) – When the queue is full to 2/3, packets will be dropped with 50% probability. When the queue is full to 3/4, packets will be dropped with 75% probability.



Warning

The *Smart discard* mode activation deactivates the *Flow control*.

6.3.5. Settings – Service access

Services

Access routes for link configuration.

	Local	Peer
IPv4 address	192.168.141.226	192.168.141.227
Netmask	24	24
Gateway	192.168.141.254	192.168.141.254
HTTP(S)	<input checked="" type="checkbox"/>	<input checked="" type="checkbox"/>
Telnet	<input type="checkbox"/>	<input type="checkbox"/>
SSH	on	on
Management VLAN	<input type="checkbox"/>	<input type="checkbox"/>
Management VLAN id	1	1
SHIMP	<input type="checkbox"/>	<input type="checkbox"/>
SHIMP community string	public	public
SHIMP trap IP	0.0.0.0	0.0.0.0
Internal link watchdog	<input type="checkbox"/>	<input type="checkbox"/>

Fig. 6.14: Configuration menu Settings – Service access – Services

IPv4 address Service IP address, by default 192.168.169.169 for L station and 192.168.169.170 for U station. Four addresses 169.254.173.236/30 are used for internal communication. Must not be used as service IP address.

Unknown IP address For easier identification of service IP address, RAY is equipped with LLDP protocol. Protocol sends a broadcast every 60 seconds with the following information:

- IP address – under LLDP: Management address
- Serial number – LLDP: System Description
- Type (e.g. RAY17_L) – LLDP: Chassis Subtype
- DATA_PORT for version with 1 eth or SERVICE_PORT for version with 2 eth – under LLDP: Port Subtype

Message can be recorded and converted into a readable form using a LLDP client. A suitable tool for this purpose is Wireshark IP traffic analysing tool, with free licenses available both for Windows and Linux. To locate the message easily, use the Capture filter "ether proto 0x88cc" in Wireshark.

Netmask Mask for service access, 24 by default.

Gateway Default gateway for service access, empty by default.

HTTP(S) Allowing access via HTTP server (for HTTP and HTTPS protocol). Attention: after disabling access via HTTP server, you will not be able to access the unit using a web browser!

- Telnet** Enabling access via Telnet server. Provides access to CLI (Command Line Interface) for simple telnet clients. Disabled by default.
- SSH** Enabling access via SSH server. Provides secure access to CLI. If preventing unauthorized access to the station is number one priority, leave only this server on.
- Management VLAN** Enabling access via VLAN management. Blocks access for https, ssh and telnet configuration via untagged packets (without VLAN) making only VLAN access possible. VLAN management is off by default. In case of RAY unit with two ports, VLAN management applies to the service port.
- ATTENTION-
By enabling VLAN management, ALL accesses are blocked for configuration using normal (untagged) LAN! During tests, you may enable VLAN management on one unit only. Then it is possible to access the link via LAN and VLAN either directly or via radio link.
- Management VLAN id** VLAN management id, by default 1. This field has to be filled out even when VLAN management is not active.
- SNMP** Enabling SNMP server. Off by default.
- SNMP community string** SNMP community string. Can contain both lower and uppercase letters, numbers, four characters . : _ - and can be up to 256 characters long.
- SNMP trap IP** Address for sending SNMP traps.
- Internal link watchdog** Watching over connection of both link units. In case of prolonged failure (10 min) a cold restart is done (the equivalent of turning off the power). Off by default.

Users

List and setup of users. There can be different users on either side of the link.

Local: Location_A / 09:38 Link: [Ok](#) Peer: Location_B / 09:37

Services **Users**

Local

Username	Group	Password	SSH key	Edit
super	cli_super	Set	Set	
admin	cli_admin	Set	None	Edit
guest	cli_guest	Set	None	
servis	cli_admin	Set	None	
guest2	cli_guest	Set	None	
distributor	cli_super	Set	None	

Peer

Username	Group	Password	SSH key
super	cli_super	Set	None
admin	cli_admin	Set	None
guest	cli_guest	Set	None
pepe	cli_guest	Set	None
pepek	cli_admin	Set	None
distributor	cli_super	Set	None

[Add user](#) [Refresh](#) [Mirror users](#)

Fig. 6.15: Configuration menu Settings – Service access – Users

Local, Peer List of users on Local and Peer stations.

Username User name. This name is entered as Login to log into the link management.

Group User group to which the user belongs.

cli_guest This group has the right to only view the setting of the link. Does not have rights to modify the settings. A group can contain a maximum of 10 users.

cli_admin The group has all the rights of group cli_guest plus:
Right to configure the link. Has the right to view and modify all settings (except for user accounts and special actions of the user *distributor*). A group can contain a maximum of 10 users.

cli_super Same rights as cli_admin plus:
Right to configure user accounts including SSH keys.. This group contains only two users:

User *super*.

User *distributor* has an additional right to change special configuration items. The password for this user cannot be changed.

Password Information about whether user has a password

SSH key Information about whether user has at least one ssh key defined.

Edit user

Clicking *Edit* next to a username opens a screen with configuration of the given account.

The screenshot shows a web interface for editing a user. At the top, there are two tabs: 'Services' and 'Users', with 'Users' selected. Below the tabs is a form titled 'Edit user'. The form contains the following fields and options:

- Username:** admin
- Group:** cli_admin
- Password:** Radio buttons for 'Delete' and 'Set' (selected).
- New password:** Text input field.
- Confirm password:** Text input field.
- SSH key:** Radio buttons for 'Delete', 'Set/replace' (selected), and 'Add'.
- Key file:** Text input field with a 'Procházet...' button next to it.

At the bottom of the form, there are two buttons: 'Apply' and 'Cancel'.

Configuration menu Settings – Service access – Users – Edit

- Username** User name
 - Group** The group to which the user belongs.
 - Password** Password can be set or deleted.
 - Delete** – User will not have a password. The user will only be able to log in with a ssh key. In order to delete the password, you must first upload ssh key.
 - Set** – Password settings.
 - New password** New password.
 - Confirm password** Repeat password.
 - SSH key** Working with ssh key.
 - Delete** – Clear all ssh keys of the user.
 - Set/replace** – Add a new key. If there already was any key(s), it will be overwritten.
 - Add** – Add a new key. You can enter multiple ssh keys this way.
 - Key file** Insert key file.
- Save the menu content by clicking on the button *Apply*.

Delete user

Users from the group cli_super have a *Delete* button next to them. You can delete a user using that button. User is removed without further queries. Users from the group cli_super cannot be deleted.

Add user

The button is located on the bottom bar.

For users from the group cli_super, the *Add user* button is active. You can use it to create a new user from groups cli_quest or cli_admin.

Username	Name of new user.
Group	The group to which this user will belong.
New password	Password for this user.
Confirm password	Repeat password.
SSH key	If you want the user to have access using ssh protocol and identity verification using ssh key, enter the ssh key here.

Create a new user by clicking on the button *Apply*.

Mirror users

The button is located on the bottom bar.

For users from the group `cli_super`, the *Mirror users* button is active. Selecting this function will copy all user accounts from Local station to Peer station. Existing user accounts on the Peer station are deleted (except for the password of distributor, which is unique for each station).

6.3.6. Settings – Alarm limits

The screenshot shows the 'Alarm limits' configuration page. At the top, there is a status bar with 'Local: Location_A / 09:52', 'Link: Ok', and 'Peer: Location_B / 09:52'. Below this is a table of alarm limits. The table has columns for 'Local Limit', 'SNMP trap', and 'Peer Limit'. The rows include 'Inside temperature [°C]', 'Memory usage [%]', 'Voltage min [V]', 'Voltage max [V]', 'RSS [dBm]', 'SNR [dB]', 'BER [-]', 'Peer disconnect', and 'Peer eth link down'. Each row has a comparison operator (> or <), a text input field for the limit value, and a checkbox for the SNMP trap. The 'Apply', 'Cancel', 'Refresh', 'Load defaults', and 'Load custom' buttons are at the bottom.

	Local Limit	SNMP trap	Peer Limit	SNMP trap
Inside temperature [°C]	> 80	<input type="checkbox"/>	80	<input type="checkbox"/>
Memory usage [%]	> 95	<input type="checkbox"/>	95	<input type="checkbox"/>
Voltage min [V]	< 40	<input type="checkbox"/>	40	<input type="checkbox"/>
Voltage max [V]	> 60	<input type="checkbox"/>	60	<input type="checkbox"/>
RSS [dBm]	< -80	<input type="checkbox"/>	-80	<input type="checkbox"/>
SNR [dB]	< 10	<input type="checkbox"/>	10	<input type="checkbox"/>
BER [-]	> 10e-6	<input type="checkbox"/>	10e-6	<input type="checkbox"/>
Peer disconnect		<input type="checkbox"/>		<input type="checkbox"/>
Peer eth link down		<input type="checkbox"/>		<input type="checkbox"/>

Fig. 6.16: Configuration menu Settings – Alarm limits

Diagnostic system of the link monitors the operation of the station. It generates various events as output. There are two kinds of events: Warnings and Alarms. The event is always written to the system log and indicated in the status bar. Some events have configurable thresholds. For each event you can choose whether a SNMP trap should be sent if the event occurs.

List of configurable events with default thresholds:

Warning

Inside temperature [°C]	>80	Temperature inside the station (on the modem board.)
Memory usage [%]	>90	Memory usage.
Voltage min [V]	<40	Lower threshold of supply voltage.
Voltage max [V]	>70	Upper threshold of supply voltage, SNMP trap on/off is generated same as for Voltage min.
RSS [dBm]	<-80	Received signal strength.
SNR [dBm]	<10	Signal to Noise Ratio.

Alarm

BER	>10e⁻⁶	Bit Error Rate registered at the receiving end. Instantaneous value.
Peer disconnect		Interruption of radio link.
Peer eth link down		User eth link on Peer station interrupted.
RF power fail		Loss of transmit power (not for RAY17 neither RAY24).

6.4. Diagnostics

6.4.1. Diagnostics – Graphs

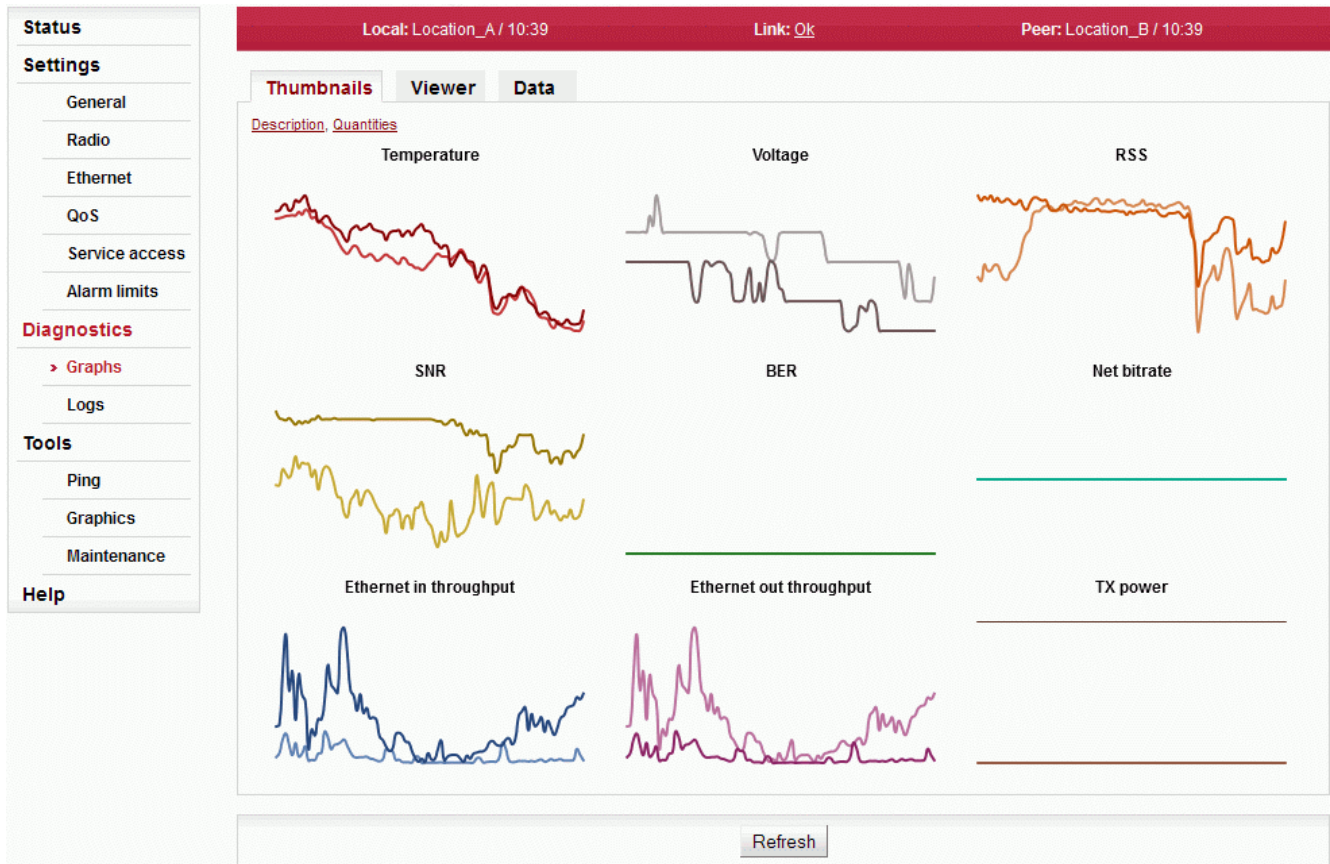

Fig. 6.17: Configuration menu Diagnostics – Graphs

Station continuously stores information about the values of important variables:

Temperature inside the station	Instantaneous value of temperature inside the station. Measured on the modem board. Temperature of radio board is available via SNMP.
Supply voltage	Instantaneous value of station supply voltage.
RSS	Received signal strength.
SNR	Signal-to-noise ratio of the received signal.
BER	Instantaneous bit error rate on link.
Net bitrate	Instantaneous transmission capacity.
Ethernet in throughput	Instantaneous speed (20s average) of incoming user data on the user Ethernet port.
Ethernet out throughput	Instantaneous speed (20s average) of outgoing user data on the user Ethernet port.
TX power	Instantaneous value of transmission power.

The values are saved in the following resolutions and history lengths

- Resolution 1 minute, length of history 1 week
- Resolution 15 minutes, length of history 30 days
- Resolution 1 day, length of history about 180 days

Stored values can be viewed using three methods:

Thumbnails	Preview all values for the last 24 hours
Viewer	Detailed graphical view of one or two selected values for the given interval
Data	Numerical view of all values

Viewer

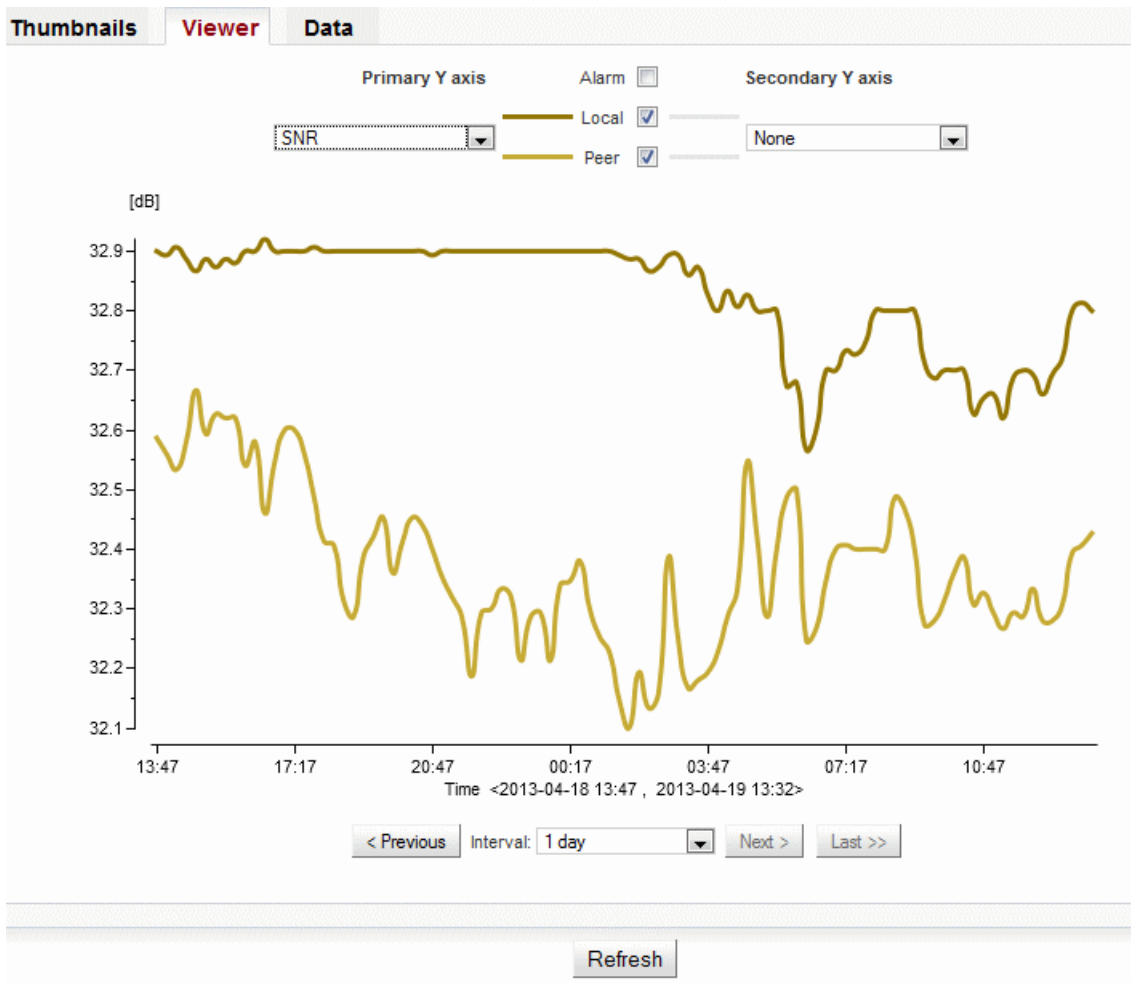

Fig. 6.18: Configuration menu Diagnostics – Graphs – Viewer

Detailed graphical view of one or two selected values for the given interval. You can choose to view data from Local or Peer or both.

- Primary Y axis** Selecting one of the observed values.
- Secondary Y axis** Selecting a second value.
- Alarm** Enables the display of alarms, if there were any.
- Local** Displays graph from Local unit.
- Peer** Displays graph from Peer unit.
- Interval** Selecting width of interval to be displayed. Based on the interval width, data are displayed in a suitable grid: Up to 3 hours in at one minute. Up to 4 days at 15 minutes. For longer intervals at one day.
- Previous** Move by one width of selected interval towards older values.
- Next** Move by one width of selected interval towards newer values.
- Last** Move to the newest values.

Data

Local: Location_A / 12:37 Link: [Ok](#) Peer: Location_B / 12:37

Quantities Plotted Local Peer All

Time	Tempe...	RSS [d...	Tempe...	RSS [d...
2013-04-22 12:30	58.51	-60.60	58.05	-65.70
2013-04-22 12:45	58.92	-60.60	58.19	-65.70
2013-04-22 13:00	58.96	-60.60	58.36	-65.71
2013-04-22 13:15	58.58	-60.60	58.49	-65.70
2013-04-22 13:30	58.50	-60.60	58.50	-65.71
2013-04-22 13:45	58.67	-60.62	58.50	-65.79
2013-04-22 14:00	58.49	-60.63	58.49	-65.76
2013-04-22 14:15	57.69	-60.60	58.03	-65.76
2013-04-22 14:30	57.44	-60.60	57.71	-65.88
2013-04-22 14:45	57.00	-60.60	57.50	-65.81

Fig. 6.19: Configuration menu Diagnostics – Graphs – Data

Detailed graphical view of values for selected interval.

Plotted

Shows only the values that are selected for the graph.

Local

Shows all logged values. Filtering of values from local, remote or both.

Peer**All**

6.4.2. Diagnostics – Logs

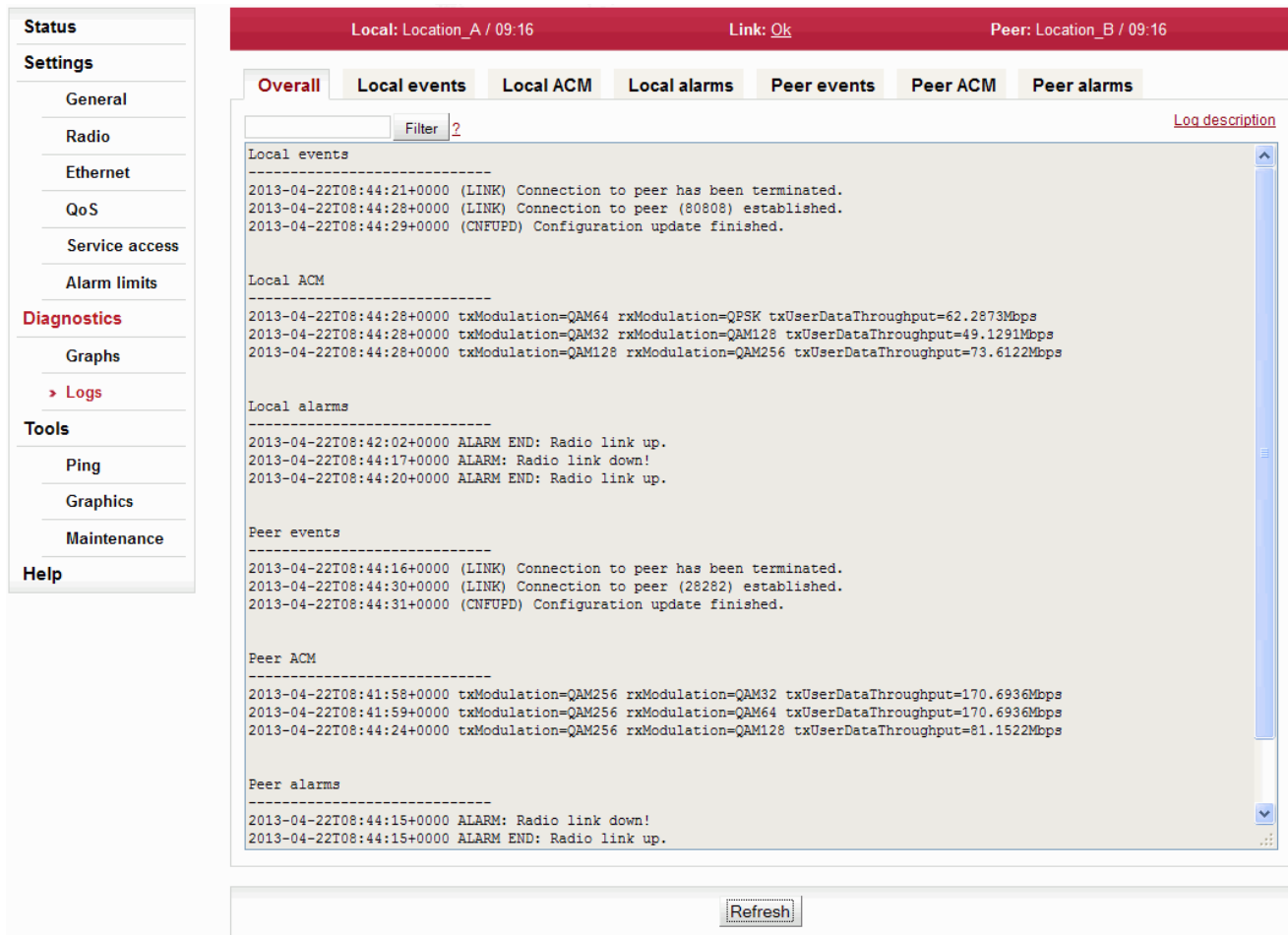

Fig. 6.20: Configuration menu Diagnostics – Logs

Shows internal station logs. Individual tabs allow total or filtered view.

When you first open the screen, it is necessary to start browsing logs by pressing the Refresh button.

Listings of all logs can be filtered. You can enter text in the upper left corner window for filtering listings. For example, you want to know when was the configuration of the station modified: On the Local events screen, enter “Configuration” and hit Enter.

You can use plain text or regular expressions for filtering (JavaScript format).

- Overall** Displays the last 3 records from all types of logs.
- Local events, Peer events** Events from Local or Peer station.
- Local ACM, Peer ACM** History of modulation switching if ACM is enabled. Local and Peer station.
- Local alarms, Peer alarms** Alarms from Local or Peer station.

Maximum length of displayed logs is 250 entries. If you need to display longer history, use of CLI interface is needed.

6.5. Tools

Menu Tools contains several support tools for link diagnostics and management.

6.5.1. Tools – Ping

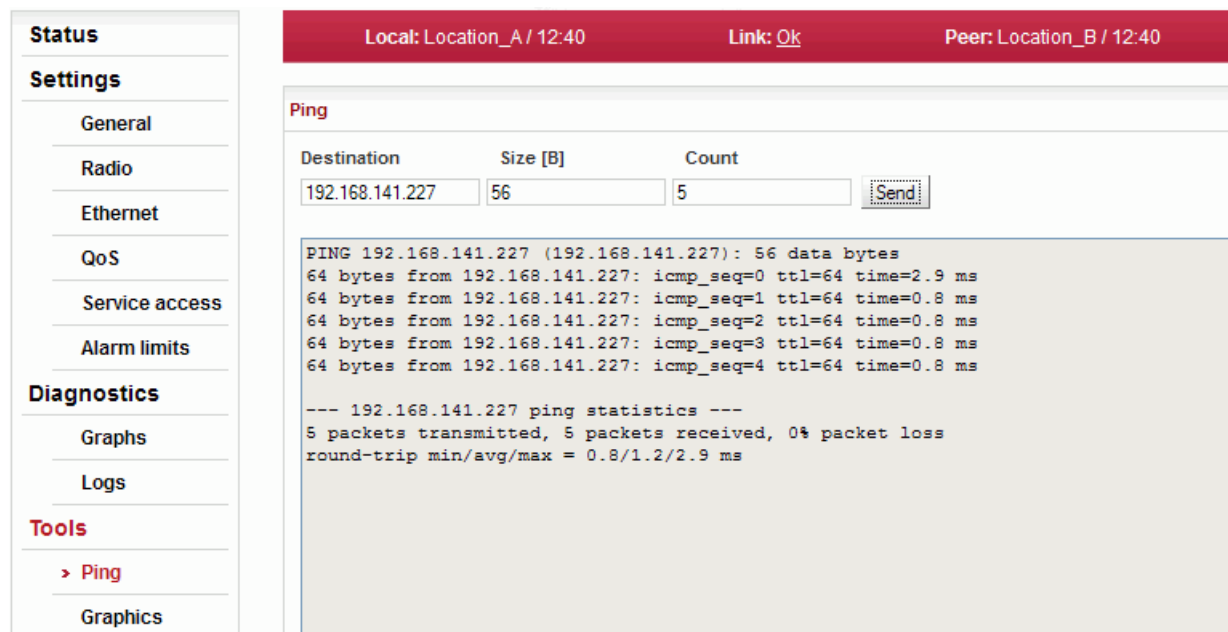

Fig. 6.21: Configuration menu Tools – Ping

The Ping tool allows sending ICMP pings to a selected address

Destination	Destination address in dotted decimal notation. The default address 127.0.0.1 is the localhost address - i.e. the station itself.
Size [B]	Length of sent data 7 to 1500 bytes, 8 bytes of the header will be added.
Timeout	The period for sending pings is constant: 1000 ms.
Count	Number of sent pings.

Start the test by clicking on **Send**. The result is displayed in the text window.

6.5.2. Tools – Graphics

Bar indicators

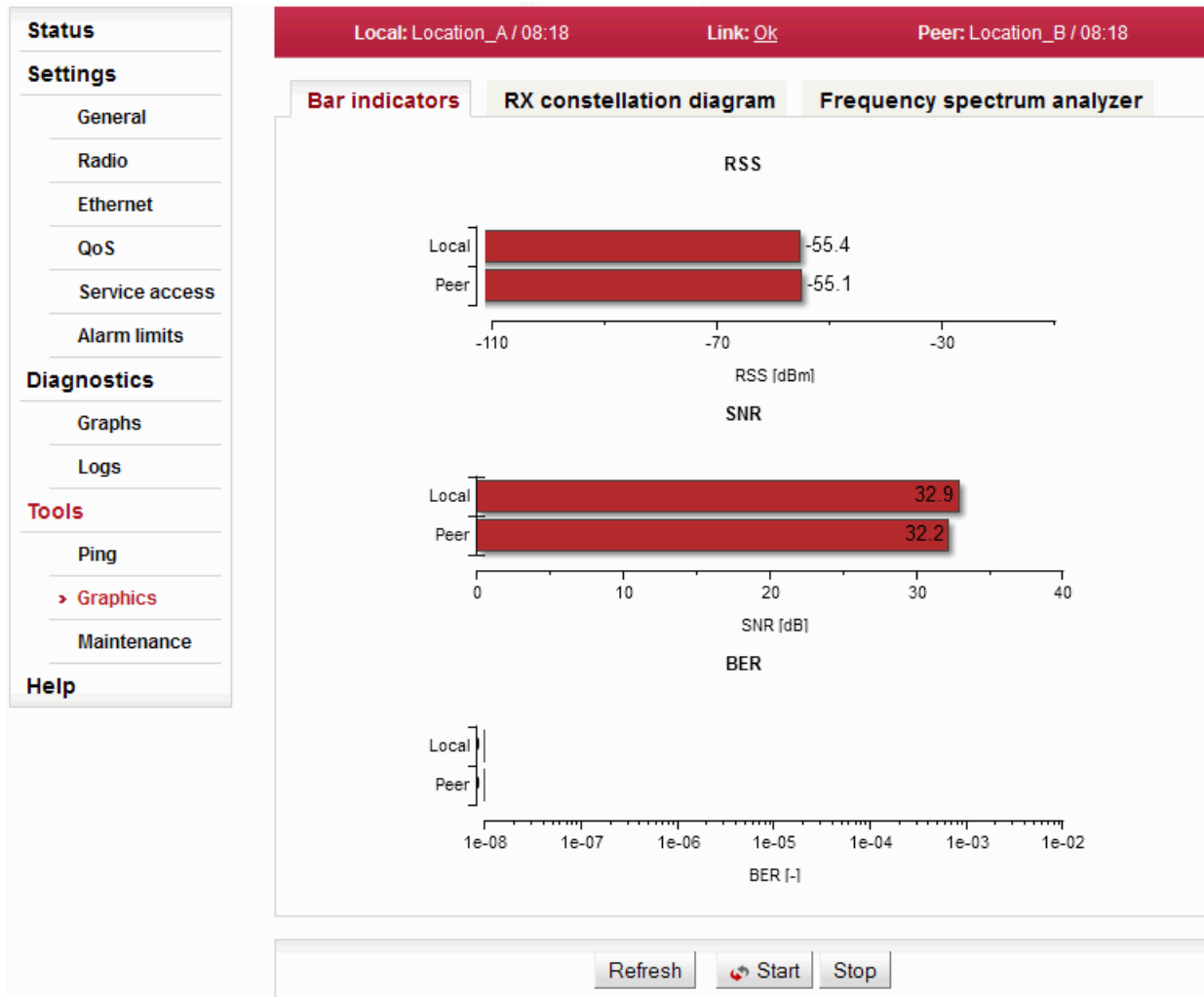

Fig. 6.22: Configuration menu Tools – Graphics – Bar indicators

Graphical indication of BER, SNR and RSS.

Refresh

One-time update of displayed values.

Start, Stop

Use the Start button to start automatic update of displayed values with a period of 1 second. Use the Stop button to stop it.

RX constellation diagram

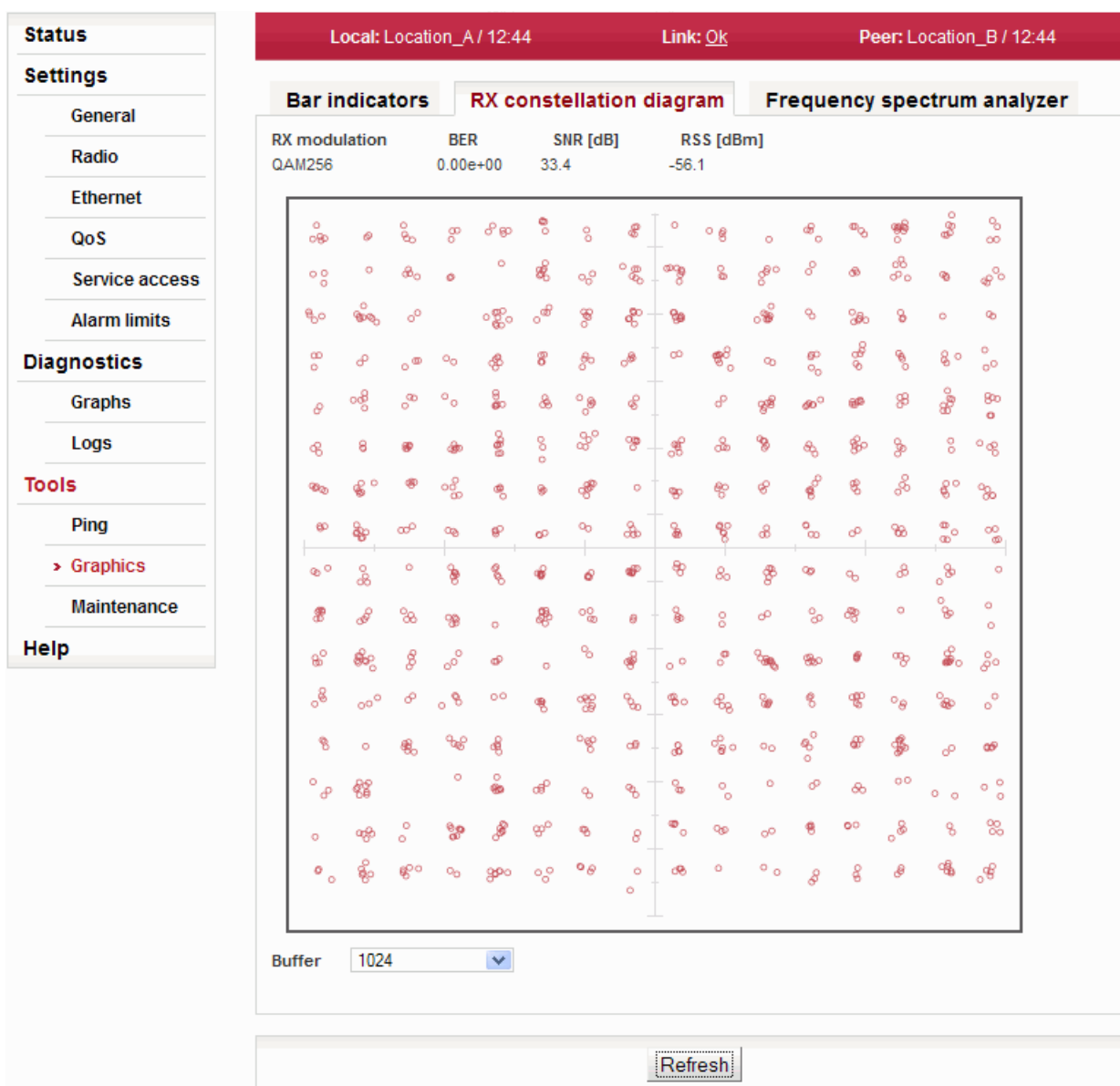

Fig. 6.23: Configuration menu Tools – Graphics – RX constellation diagram

Constellation diagram shows the quality of received signal.

Buffer	Number of plotted points.
Refresh	One-time update of diagram.

Frequency analyser

The screenshot shows the 'Frequency analyser' configuration page. On the left is a sidebar menu with categories: Status, Settings (General, Radio, Ethernet, QoS, Service access, Alarm limits), Diagnostics (Graphs, Logs), Tools (Ping, Graphics, Maintenance), and Help. The 'Graphics' tool is selected. The main panel shows connection details: Local: Location_B / 13:10, Link: Ok, Peer: Location_A / 13:10. Three tabs are visible: Bar indicators, RX constellation diagram, and Frequency spectrum analyzer. The 'Frequency spectrum analyzer' tab is active, displaying a bar chart of Received Signal Strength (RSS) in dBm versus frequency (f) in GHz. The y-axis ranges from -110 to -10 dBm, and the x-axis ranges from 17.10 to 17.30 GHz. The chart shows a noise floor at -110 dBm and three distinct peaks between 17.14 and 17.18 GHz, with the highest peak at approximately -65 dBm. Below the chart are controls for 'Frequency spectrum measure time' (set to 'single'), 'Mute peer TX' (checkbox), and a warning message: 'Warning! Before starting the Frequency spectrum analyzer, make sure that the link can really go down (it will)'. At the bottom are 'Enable' and 'Start' buttons.

Fig. 6.24: Configuration menu Tools – Graphics – Frequency analyser

A very useful tool for identifying in-band interference and locating a free channel. It is not a full-blown spectrum analyser as it scans the spectrum with 7MHz channel resolution. The accuracy of measured results is given by the accuracy of measuring RSS.



Warning

Running spectrum measurement causes interruption of user data flow between stations!

Spectrum measure time Selection of measurement length in range:
single sweep ... up to 15 min

Mute peer TX The deactivation of Peer station transmission during measurement.

Enable Opening analyser functions

Start Interrupts communication on the link and starts scanning frequencies in the band.

6.5.3. Tools – Maintenance

■ Restart

The screenshot shows the 'Restart' configuration page. On the left is a sidebar with 'Status' and 'Settings' sections. The main content area has a red header with 'Local: Location_B / 13:19', 'Link: Ok', and 'Peer: Location_A / 13:19'. Below the header are tabs for 'Restart', 'Backup', 'Feature keys', 'Firmware', and 'Radio adaptation'. The 'Restart' tab is active, showing options for 'Target' (Local and Peer), 'Restart mode' (warm), and a 'System restart' button.

Fig. 6.25: Configuration menu Tools – Maintenance – Restart

Target	Restart of selected unit, Local or Peer.
Restart mode	Warm – reboot management system. Cold – restart the whole station as if power was removed.
System restart	Performs the selected restart.

■ Backup

The screenshot shows the 'Backup' configuration page. On the left is a sidebar with 'Status', 'Settings', 'Diagnostics', 'Tools', and 'Help' sections. The main content area has a red header with 'Local: Location_B / 13:20', 'Link: Ok', and 'Peer: Location_A / 13:20'. Below the header are tabs for 'Restart', 'Backup', 'Feature keys', 'Firmware', and 'Radio adaptation'. The 'Backup' tab is active, showing sections for 'Settings', 'Factory settings', 'Users', 'Management Information Base', and 'Diagnostic package', each with 'Download' or 'Restore' buttons.

Fig. 6.26: Configuration menu Tools – Maintenance – Backup

Settings

Saving and restoring configuration.

- Backup** Saving configuration to backup file.
- Upload** Upload configuration from a backup file into buffer. RAY continues to run with the current configuration.
- Custom settings** Restoring the configuration parameters from the buffer. Parameters must be prepared using *Upload*.
- Default settings** Applying default values to all configuration parameters.

Factory settings

Using the factory settings function will return the unit to its original state. All configuration items, user accounts, measured values and system messages (logs) will be irreversibly deleted.



Warning

This task takes a few minutes to complete. Do not interrupt the power supply during the operation.

- Local** Applying Factory settings to Local station.

Users

Saving and restoring user accounts.

- Backup** Saving user accounts to backup file.
- Restore** Restoring user accounts from a backup file.

Management Information Base

- SNMP MIB** Provides MIB table.

Diagnostic package

To facilitate communication with the technical support you can create an archive file with detailed information about the station. If connection with Peer station is functional, information from both stations is saved.

- Backup** Saving a file with information about the station (Local and Peer).

■ Feature keys

Local: Location_B / 13:22 Link: Ok Peer: Location_A / 13:22

Restart Backup **Feature keys** Firmware Radio adaptation

Local

Note: Changes of feature keys takes effect after [restart](#).

Feature	Limit	Remove
speed	50	Delete
speed	75	Delete
master	1	Delete

Upload local feature keys

Note: Changes of feature keys takes effect after [restart](#).

Upload Open file upload

Peer

Feature	Limit
speed	49
master	1

Refresh

Fig. 6.27: Configuration menu Tools – Maintenance – Firmware

The sub-set of RAY parameters is affected by use of Feature keys.

The feature keys limiting data transfer speed [Mbps] are now available. Speed of the transferred data is determined by a combination of the radio channel bandwidth (parameter Bandwidth [MHz]) and modulation order (parameter TX modulation). The Feature key limiting the data transfer speed enables only certain combinations of the channel bandwidth and modulation order to get the data transfer speed according to the Feature key. The data transfer speed is typically slightly higher than declared.

When installed, the Feature key is activated after the **station restart**. The station can be restarted using the *Tools-Maintenance-Restart* menu. Choose the *warm Restart* mode.

Local

The active Feature keys in the Local station.

Feature	Name of the function controlled by the Feature key.
Limit	The numeric value set by the key.
Remove	The specific Feature key can be deleted using the Delete button. The parameters controlled by this Feature key are reset to their default values after the station restart. Note: The link radio parameters can be changed subsequently (e.g. to a different operating frequency)!
Upload local feature keys	Feature keys are installed into the station from the binary files.
Open file upload	Dialog for the Feature key binary file selection is open.

Peer

Peer station active Feature keys. Feature keys of the Peer station are only displayed. They can be neither added, nor deleted. To be able to manipulate the Feature keys, it is necessary to access directly management interface of the relevant station - use the IP address of the relevant station.

Feature Name of the function controlled by the Feature key.

Limit The numeric value set by the key.

■ **Firmware**

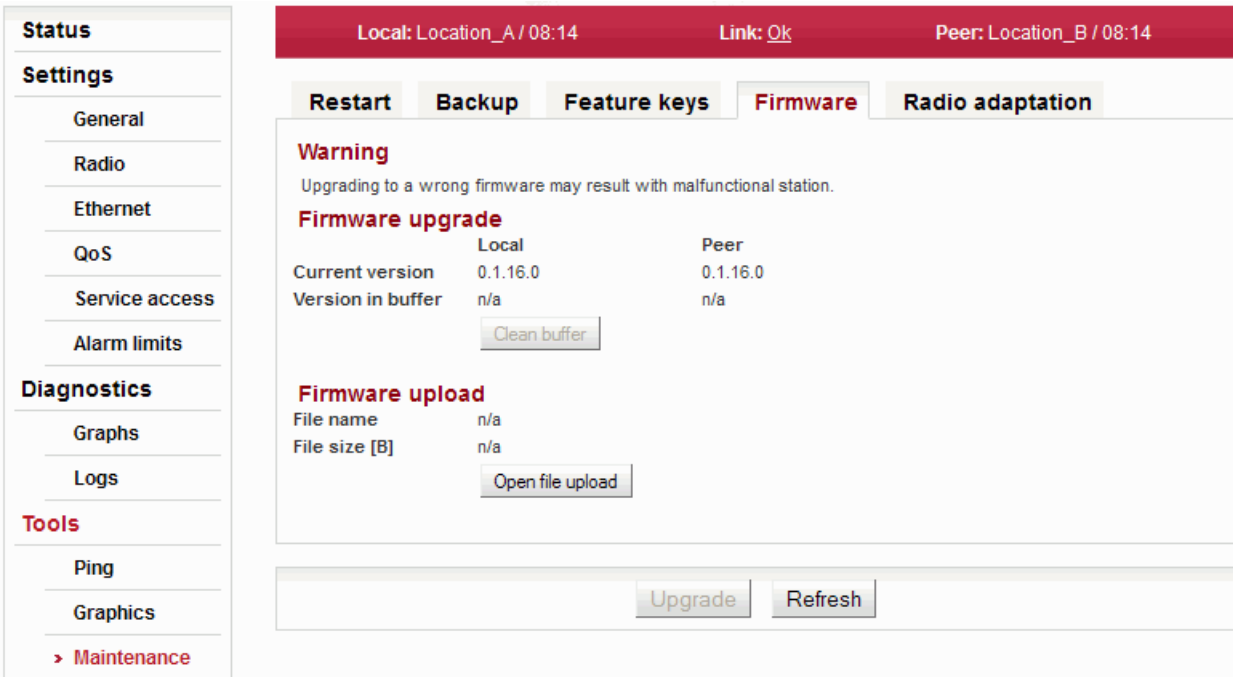

Fig. 6.28: Configuration menu Tools – Maintenance – Firmware

If a new firmware version is released for the given microwave link type, you can upload it to your RAY units.

Firmware upgrade

Current version Information about the current firmware version on Local and Peer station.

Version in buffer Information about firmware version prepared in the buffer for installation into the unit (Local, Peer). This firmware must first be prepared in the Firmware upload section (see below).

Clean buffer You can use the Clean buffer button to delete prepared firmware package in the buffer.

Firmware upload

File name Name of the firmware file

File size [B] Size of the firmware file

Open file upload Opens a dialog for uploading firmware package to the unit buffer. Only after firmware has been prepared in the buffer, you can perform the actual upgrade.

Upgrade Use the *Upgrade* button on the bottom bar to perform the firmware installation.



Warning

Installing the firmware takes several minutes (about 10 minutes). During this time, transmission of user data is interrupted (for about 8 minutes). Do not interrupt the power supply during firmware installation!

■ Radio adaptation

Fig. 6.29: Configuration menu Tools – Maintenance – Radio adaptation

Radio type



Important

Applies only to links operating in the ISM band (RAy17, RAY24).

Hardware of these links is universal for the entire frequency band. To facilitate the configuration of radio parameters, units are coded for L (Lower) and U (Upper) part of the band. L or U band assignment can be modified.

Radio type Radio unit type: L (Lower) or U (Upper) part of the frequency band. Use the *Change* button to change the radio type.

Frequency tables

The microwave link contains one or more frequency tables. These tables contain the following information:

- List of available bandwidths and modulations.
- Assignment of frequencies to the channels and the names of these channels. These channels are used to configure radio parameters of the link (see screen Settings-Radio).
- Default values of radio parameters.
- A set of radio parameters, needed for the ATPC operation.

Active

Name of the currently used frequency table.

New

Select a new frequency table. Use the *Change* button to change the table.



Warning

Using the wrong frequency table can lead to violation of the corresponding telecommunications regulations.

6.6. Help

The Help screen displays contents of the embedded help. The help text is displayed in the whole configuration window. The text structure corresponds to individual configuration screens.

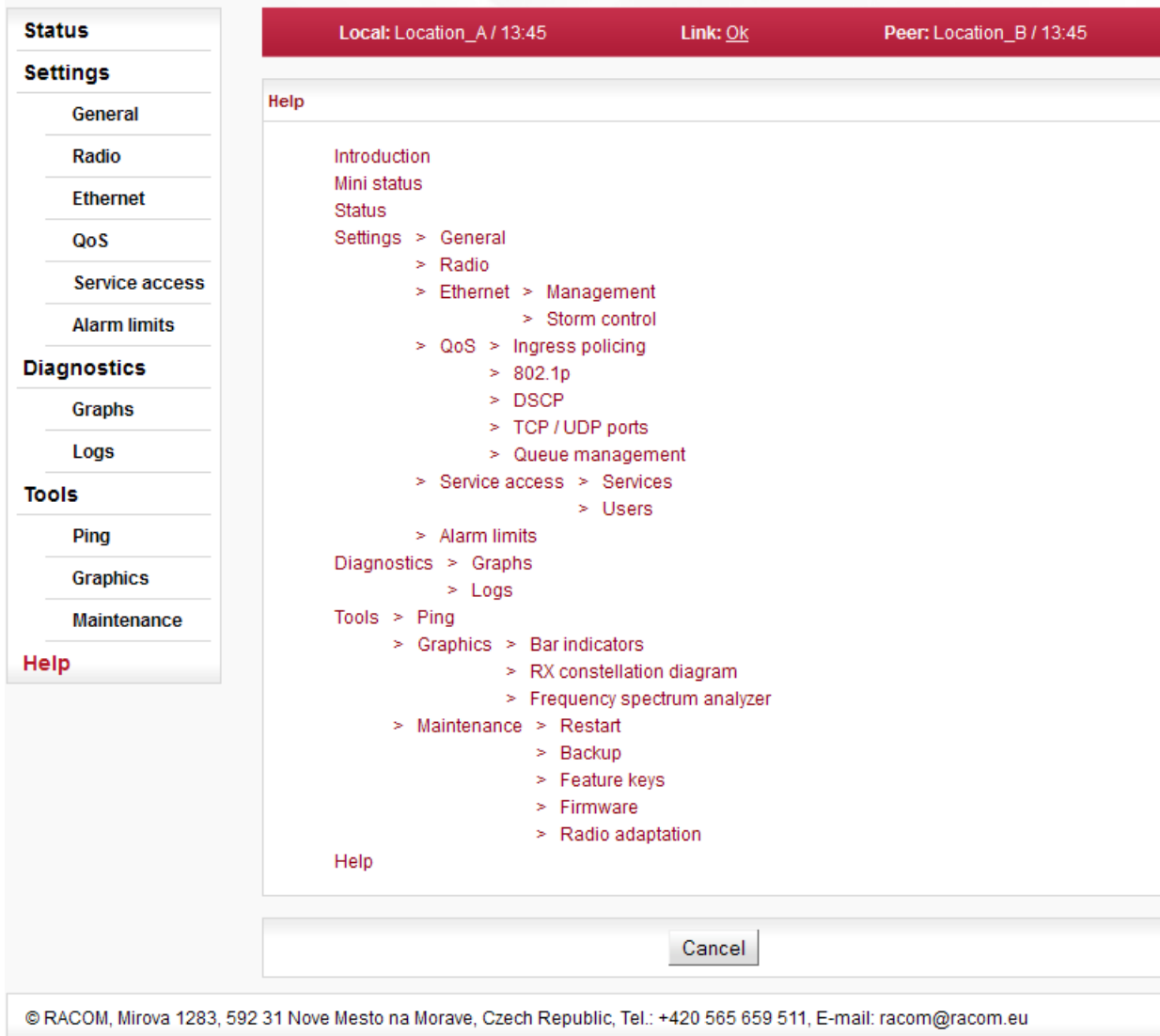

Fig. 6.30: Menu Help

Every item of this Help opens the specific menu help.

Clicking the name of the specific parameter in the configuration menu brings the help belonging to this parameter. The help text is displayed in the pop up window:

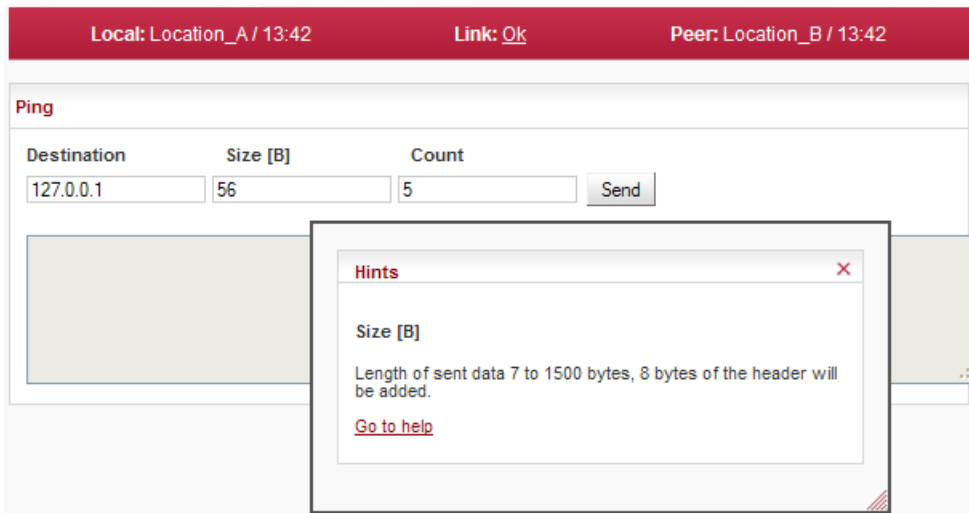

Fig. 6.31: Parameter help

The window can be moved by dragging the *Hints* bar. Resize it by dragging the bottom corner.

There is a *Go to help* link within the help text. The whole configuration menu help text is displayed by clicking this link:

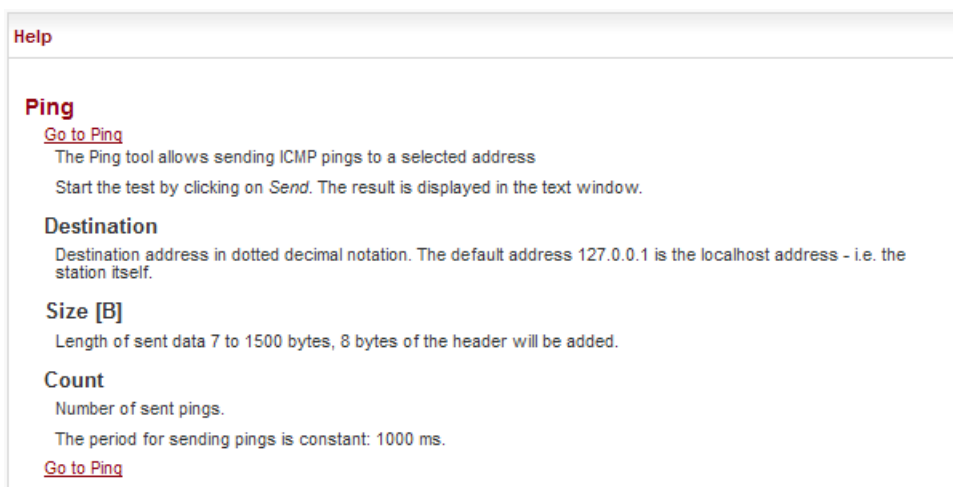

Fig. 6.32: Configuration menu help

There is a link at the beginning and end of each help screen which points to the respective configuration screen.

7. Command Line Interface

Command Line Interface (CLI) provides an alternative to HTTPS access. CLI allows you to work in text regime using a ssh (putty) or telnet client.

7.1. Connection via CLI

Using the **telnet** client to connect to unit with service IP address 192.168.169.169. Type this in the command prompt:

```
telnet 192.168.169.169
```

Then use the username and password from the menu `Service access/Users` for https access (by default `admin, admin`). Works if `Service access/Services/Telnet` is checked in https access.

Connection using **putty client**. Type this into the Host Name (or IP address) field:

```
admin@192.168.169.169
```

Click Open. Then enter the password `admin`. This procedure (without key) is subject to selection `Service access/Services/SSH` **on** in https access.

If you own the private key part, then you do not need a password. In putty, continue by selecting `Connection/SSH/Auth` and selecting path to file with key e.g. `key.ppk`. Use `Session/Logging` to save the putty configuration. To access the unit via CLI simply select the connection in putty and click Open.

Connection using client **ssh** in Linux.

```
ssh admin@192.168.169.169 -i key
```

If you know the password and it is enabled in `Service access/Services/SSH` **onlykey** in https access, you can skip the key and use password in the next query.

7.2. Working with CLI

- Overview of CLI options

cli_help

```

192.168.141.202 - PuTTY
Using username "admin".
admin@192.168.141.202's password:

BusyBox v1.2.2 (2012.10.10-19:50+0000) Built-in shell (ash)
Enter 'help' for a list of built-in commands.
Fri Nov 30 07:38:20 UTC 2012
Welcome to Ray Command Line Interface (CLI) on station: RAY17L

For help try: cli_help

CLI(admin):/rrusrhomes/admin$ cli_help
CLI commands:
- configuration:
  cli_cnf_backup_get      - create configuration backup package
  cli_cnf_def_show        - show default configuration
  cli_cnf_factory_set     - return to factory settings
  cli_cnf_set             - update configuration
  cli_cnf_show            - show configuration
  cli_time_set           - change time
- radio channel configuration:
  cli_rcinfo_list        - show list of stored and active rcinfo files
  cli_rcinfo_load        - load rcinfo package into storage
    
```

Fig. 7.1: CLI menu

- Parameters of CLI commands are listed in the help. For example:

- h help listing
- t target unit
- t l local, default option
- t b both, both units, command item for remote unit has PEER_ prefix
- t p peer, opposite unit, when reading using the show command

- When inserting commands, adding with tabulator can help
- Incorrect command is rejected (e.g. inserting forbidden frequency)
- Parameter that caused the loss of the connection is restored after 1 minute (Rollback)
- Reading parameters of local unit
cli_cnf_show
- Reading radio parameters of peer unit
cli_cnf_show -t p | grep RADIO
- Entering parameters (TX power of local unit)
cli_cnf_set RADIO_TX_PWR=-3
Items of command (RADIO_TX_PWR=) are taken from the list cli_cnf_show

- Entering more parameters in both units

```
cli_cnf_set -t b RADIO_TX_CHAN=17128000 PEER_RADIO_RX_CHAN=17128000
```

- Put parameters containing space in quotation marks:

```
cli_time_set -t b -T '2012-11-27 10:55:00'
```

Set time in both units

7.2.1. SSH keys

- Generation using ssh-keygen

```
[user@laptop ~]$ ssh-keygen -t dsa -f usr_ssh_key
```

Uses working directory to save private `usr_ssh_key` and public part of the key `usr_ssh_key.pub`

- Copying the key into the RAY unit

```
[user@laptop ~]$ scp usr_ssh_key.pub admin@192.168.141.202:/tmp
```

The public part of the key is written to the folder `/tmp`

- Installation of key in RAY unit

```
CLI(admin):/rrusrhomes/admin$ cli_user_authkey -c a -k /tmp/usr_ssh_key.pub
```

- Test of access to RAY unit using SSH key

```
[user@laptop ~]$ ssh -i usr_ssh_key admin@192.168.141.202
```

7.2.2. Scripts

- Script example with access using key

```
[user@laptop ~]$ ssh -i usr_ssh_key admin@192.168.141.202
"source /etc/profile;cli_info_link;echo \${?};cli_cnf_show | grep TX_PWR;echo $?"
Warning: Permanently added '192.168.141.202' (DSA) to the list of known hosts.
cli_info_link: Link status: up
0
RADIO_TX_PWR=4
0
[user@laptop ~]$
```

- The script contains:

<code>source /etc/profile;</code>	environment settings
<code>cli_info_link;</code>	query for link status
<code>echo \\${?};</code>	reading return value
<code>cli_cnf_show grep TX_PWR;</code>	query for radio power
<code>echo \\${?}</code>	reading return value
<code>cli_info_link: Link status:up</code>	return value
<code>0</code>	OK command
<code>RADIO_TX_PWR=4</code>	power +4 dBm
<code>0</code>	OK command

7.3. Configuration with CLI

7.3.1. Configuration file

- Configuration backup
`cli_cnf_backup_get`
Saves the configuration of both units to file `cnf_backup.tgz` into the working directory.
- Configuration restore
`cli_cnf_set -t b -b cnf_backup.tgz`
Restores configuration of both units from file `cnf_backup.tgz`
- Default configuration - list
`cli_cnf_def_show`
Attention, the command
`cli_cnf_factory_set`
is not a default setting - it uses factory settings, deletes all logs and saved data. It is very likely that the connection to peer station will be interrupted!

7.3.2. Firmware upgrade

- Current version of fw
`cli_info_station`
- Preparation of files
fw package, for example `bm4-RACOM-0.1.12.0.cpio` copy using ssh or putty into folder `/tmp` in RAY17
Command
`cli_fw_clear_buffer`
Clears the RAY buffer
`cli_fw_buffer_status`
Checks buffer status
- Saving into buffers
`cli_fw_load_package -f /tmp/bm4-RACOM-0.1.12.0.cpio`
A new fw package is loaded into the buffer (20 sec)
`cli_fw_upload2peer`
The fw package is also loaded into the peer unit (20 sec)
- Upgrade
`cli_fw_upgrade -t b`
Firmware in both units will be replaced with new version from the buffer. After 3 minutes, this message appears:
`Firmware upgrade started. Estimated time to finish is 370 s.`
Connection is terminated. After a few minutes, log in to RAY again

7.3.3. Remote unit authorization

The RAY unit in default configuration, establishes a connection with any remote unit and both units act as a communication pair. Should the higher protection from the unauthorized communication take-over be required, it is possible to use so called Secured mode of remote unit authorization. This mode is based on locking the two specific units into one communication pair. The units with Secured mode

activated refuse to make a connection with any other communication unit. The units are locked using the unique authorization keys. The keys are exchanged between the affected units. The authorization keys can be backed up to an external medium to be able to make a service unit exchange, if necessary.

The Secured mode set up process consists of a few steps:

- Unique authorization keys generation:
`cli_link_key_gen -t b`
- Authorization keys exchange between the two communication units:
`cli_link_key_swap`
- Authorization keys activation:
`cli_link_key_apply -t b`
Parameter `-t` determines, whether we configure the whole link (`-t b`) or only one unit (`-t 1`).
- Secured mode activation. Both sides of the link has to have identically secured mode set On or Off:
`cli_cnf_set -t b SVC_SECURE_PEER_MODE=on PEER_SVC_SECURE_PEER_MODE=on`
- Secured mode de-activation:
`cli_cnf_set -t b SVC_SECURE_PEER_MODE=off PEER_SVC_SECURE_PEER_MODE=off`
- Backup of the keys to an external medium. The backup has to be performed to be able to make service exchange of the corrupted unit, if necessary. The new exchanged unit is not able to make an active connection with the other unit if it is not loaded with the proper authorization key.
`cli_link_key_save -s s -f <file>`
The key is backed up to selected file in the internal unit file system. It can be transferred to an external medium for example using the scp client.
- Authorization key restoration from the external medium.
The key has to be transferred to the unit internal file system first. Scp client can be used. The CLI commands can be applied subsequently:
`cli_link_key_load -t b -f <file>`
`cli_link_key_apply -t b`

8. Troubleshooting

- **Polarization incorrect**

To receive the *horizontal* or *vertical* message for TX the transmission axis must be horizontal, the handgrip must be either horizontal or vertical and the connectors must point downward at an angle. Each unit is evaluated separately.

- **The link cannot be established**

Start with the most “resilient” configuration. This configuration depends on the type of unit. We recommend to use the narrowest available bandwidth (e.g. 3.5 MHz), the lowest modulation level (QPSK) and maximum available output power. TX and RX channels must be the same as the RX and TX channels in the remote unit. When the connection has been established and the antennas have been directed, continue to operation parameters.

The units operating in licensed bands (RAy10, RAY11) are mounted with the same TX polarization (both unit handles horizontally or both vertically).

The units working in ISM band (RAY17, RAY24) must be mounted one with TX horizontal polarisation (horizontal handle) and the second with TX vertical polarisation (vertical handle).

- **Access to the Local unit is blocked**

Access to the Local unit may be accidentally blocked, for instance by disabling HTTPS access. If you can access the Remote unit over HTTPS, type its address in your web browser's address field. The link will transfer the packet over the Local unit with blocked service access all the way to the Remote unit, which will give you access to the control menus of both units. Attention, the Remote unit will report as Local.

- **Distinguishing Local-Remote**

The unit accessed via service access always reports as Local. If you connect through another (peer) unit and radio channel, certain amount of caution is necessary. For example, not to reduce the transmission power so that the link interrupts accidentally. Errors of this type should be fixed by rollback function within approx. 1 minute.

Resolution can be done by comparing the length of ping on Local and Remote. Pinging the unit behind the radio channel is slower. The difference is more pronounced in case of a long packet and the low speed of the radio channel.

- **Access security**

For better protection against unauthorised access to configuration you should only allow as few kinds of access as possible. The most secure type is SSH with key – leave only SSH checked.

- **RSS**

To configure the link and monitor its state, several menus display the RSS signal strength. Please keep in mind, that Ray is not a measuring instrument, hence the precision of the RSS reading is limited. Though in most situations the RSS reading accuracy is better than ± 2 dB, the absolute RSS value should not be used for accurate comparisons e.g. between two links.

- **Problem with https certificate**

See the Appendix E, *Https certificate*

9. Technical parameters

The RAY10 basic technical parameters are stated here for clarity, see the manual¹.

9.1. General parameters

9.1.1. Technical parameters overview

Type	Licensed bands		ISM bands	
	RAY10	RAY11	RAY17	RAY24
Band [GHz] sub-bands A,B..	A: 10.30 – 10.59 B: 10.15 – 10.65	A,B: 10.70 – 11.70 C,D: 10.50 – 10.68	17.1 – 17.3	24.0 – 24.25
ODU inits	Unit L and U		One universal unit	
Duplex spacing [MHz]	any combination L and U units	A,B: 490, 530 C,D: 91	optional min 60	optional min 60
Channel spacing CS [MHz]	7, 14, 28	A,B: 1.75, 3.5, 7, 14, 28, 30, 40, 56 C,D: 1.75, 3.5, 7, 14, 28	3.5, 7, 14, 28, 40, 56	3.5, 7, 14, 28, 40, 56
Channel freq.	detail ²	detail	detail	detail
User speed [Mbps]	8.5 – 170 detail ³	A,B: 2.5 – 360 C,D: 2.5 - 177 detail	4.9 – 360 detail	4.9 – 360 detail
Latency [μs]	140 (64B/170Mbps)	81 (64B/359Mbps), 234 (1518B/359Mbps)		
Sensitivity, BER 10 ⁻⁶ [dBm]	-96 (8.5 Mbps) -69 (166 Mbps) detail ⁴	-99 (2.5 Mbps) -67 (340 Mbps) detail	-96 (4.9 Mbps) -66 (340 Mbps) detail	-96 (4.9 Mbps) -65 (340 Mbps) detail
Output Power [dBm]	-5 – +10	-5 – +23 (QPSK) -5 – +17 (256QAM)	-25 – +5	-30 – +10
ATPC	no	yes	yes	yes
Consumption [W]	17	24	21	23
Weight [kg]	2.9	2.8	2.5	2.5
Radio param.	EN 302 217-2-2 V 1.3.1		EN 300 440-2 V 1.4.1	

ver. 2.1

¹ <http://www.racom.eu/eng/products/m/ray/index.html>

² http://www.racom.eu/eng/products/m/ray/tech_par.html#kmit10a

³ http://www.racom.eu/eng/products/m/ray/tech_par.html#mod10

⁴ http://www.racom.eu/cz/products/m/ray/tech_par.html#rad10

Technical parameters

Modulation	fixed QPSK, 16, 32, 64, 128, 256 QAM or ACM
FEC	LDPC
User interface	1 Gb Eth. (10/100/1000) (IEEE 802.3ac 1000BASE-T) , MTU1536B, recommended cable S/FTP CAT7
Service (optional)	100 Mb (10/100) Eth. (IEEE 802.3u 100BASE-TX) , S/FTP CAT7 or CAT5
Power	PoE, 40 - 60 VDC , IEEE 802.3at up to 100m , user interface
Operating temperature range	-30 – +55°C (ETSI EN 300019-1-4, class 4.1.)
Mechanical design	FOD (Full Outdoor)
Dimensions	245 × 245 × 150 mm
EMC	ETSI EN 301 489-1 V 1.8.1 (2008-04), ETSI EN 301 489-17 V1.3.2 (2008-04)
Electrical safety	EN 60 950-1:2004

ver. 1.0

9.1.2. Link speed

Nominal link speed

RAY xx		User data rate [Mbps]							
Modulation / CS	1.75 MHz	3.5 MHz	7 MHz	14 MHz	28 / 30 MHz		40 MHz	56 MHz	56 MHz TO
	ACCP	ACCP	ACCP	ACCP	ACCP	ACAP	ACCP	ACCP	ACCP
QPSK	2.5	4.9	8.5	19.9	36.8	38.3	50.1	72.9	85.8
16-QAM	4.9	9.6	17.2	38.8	80.9	84.1	110.0	160.2	169.9
32-QAM	6.3	12.1	22.1	49.1	102.4	106.4	139.2	202.7	206.2
64-QAM	7.4	14.3	29.7	62.3	129.8	135.0	176.5	256.9	268.1
128-QAM	8.9	17.2	34.7	73.6	155.5	161.7	211.4	303.7	309.0
256-QAM		19.7	40.7	81.2	170.7	185.2	232.1	337.7	358.9

ver. 2.5

Link speed according to RFC 2544

RAY xx		Link speed [Mbps] for frames 64 - 1518 B								minimum maximum values
Modulation / CS	1.75 MHz	3.5 MHz	7 MHz	14 MHz	28 / 30 MHz		40 MHz	56 MHz	56 MHz TO	
	ACCP	ACCP	ACCP	ACCP	ACCP	ACAP	ACCP	ACCP	ACCP	
QPSK	2.1	4.2	7.5	17.6	32.6	33.8	44.3	64.7	76.1	
	2.3	4.6	8.3	19.6	36.5	37.9	49.6	72.3	85.2	
16-QAM	4.3	8.4	15.1	34.3	71.7	74.6	97.5	142.1	150.7	
	4.8	9.3	17.0	38.5	80.2	83.4	109.2	159.0	168.6	
32-QAM	5.4	10.6	19.6	43.4	90.7	94.3	123.4	179.9	182.9	
	6.0	11.9	21.8	48.6	101.5	105.6	138.2	201.3	204.8	
64-QAM	6.5	12.6	26.1	55.2	115.1	119.7	156.6	228.0	238.1	
	7.2	14.1	29.3	61.7	128.8	133.9	175.3	255.1	266.4	
128-QAM	7.8	15.1	30.7	65.2	138.0	143.5	187.7	269.7	274.5	
	8.7	17.0	34.3	73.0	154.5	160.5	209.9	301.6	307.1	
256-QAM		17.4	36.1	71.9	151.5	164.4	206.1	300.2	318.8	
		19.4	40.3	80.5	169.5	184.0	230.7	335.8	356.5	

ver. 1.1

9.1.3. Duplex spacing

Duplex spacing L and U channels			
RAy10			
Sub-bands			
A	All combinations of channels		
B	All combinations of channels		
RAy11			
Sub-bands	Duplex spacing [MHz]		
A, B	490, 530		
C,D	91		
RAy17			
	Optional duplex spacing		
Channel width	minimum	default	maximum
[MHz]	[MHz]	[MHz]	[MHz]
3.5	60	73.5	192.5
7	60	73.5	192.5
14	65	87.5	185.5
28	70	87.5	171.5
40	70	73.5	157.5
56	85	87.5	143.5
RAy24			
	Optional duplex spacing		
Channel width	minimum	default	maximum
[MHz]	[MHz]	[MHz]	[MHz]
3.5	60	73.5	241.5
7	60	73.5	238.0
14	65	87.5	234.5
28	70	87.5	220.5
40	70	73.5	206.5
56	85	87.5	192.5

ver. 2.2

9.1.4. Frequency overview 10 GHz and 11 GHz, for CS 28 MHz

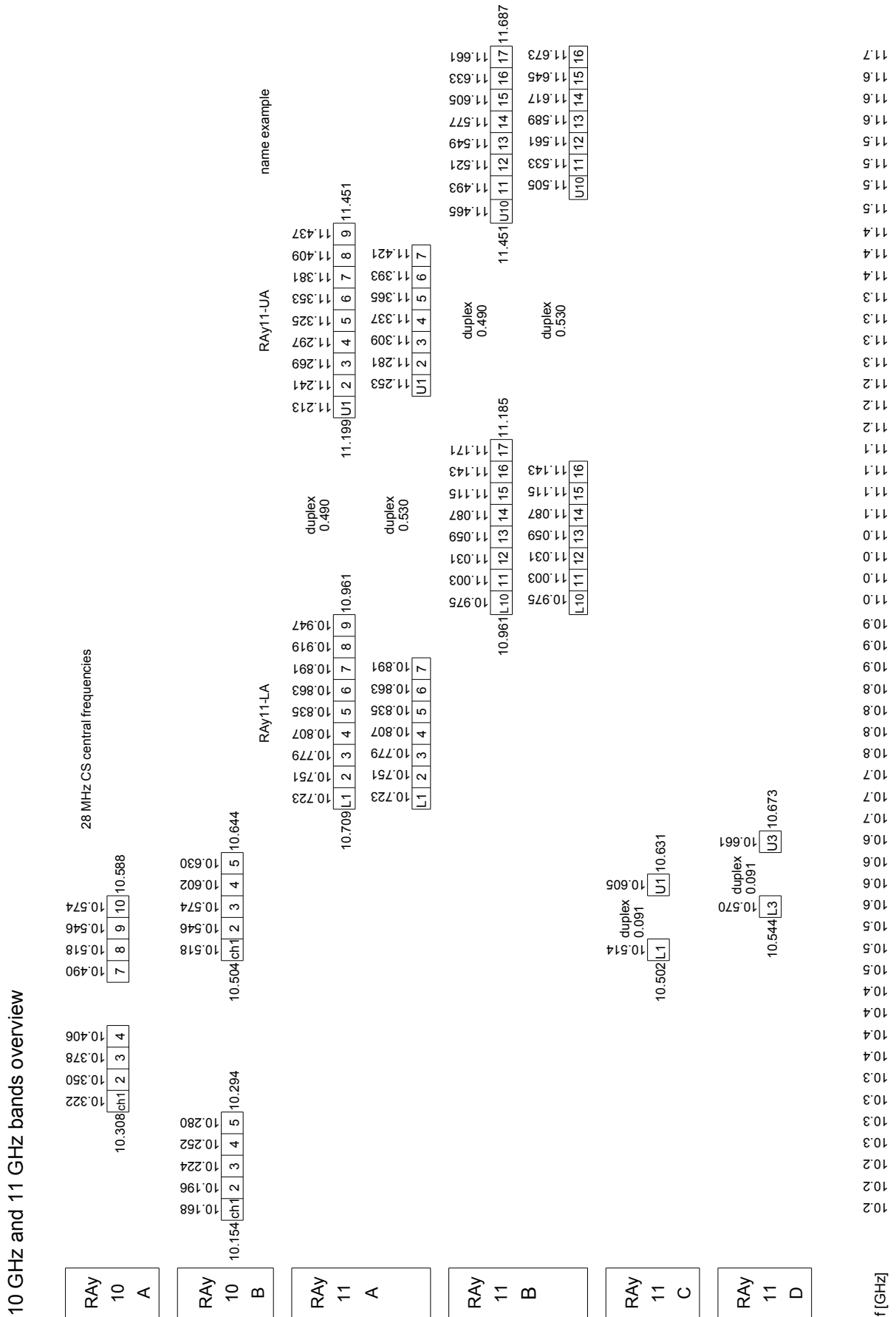

9.1.5. Nominal frequency tables description

RAy11 – xA , RAY11 – xB ¹⁾			TX channel nominal frequencies		
Bandwidth: 56 MHz (CS 80) ²⁾			Band 10.7 – 11.7 GHz, ³⁾ duplex frequency 490 MHz ⁴⁾		
A sub-band ⁶⁾ (Freq.table: rcinfo11_A_490, rcinfo11_A_490_n) ⁷⁾			B sub-band (Freq.table: rcinfo11_B_490, rcinfo11_B_490_n)		
Ch.No.	Lower [MHz]	Upper [MHz]	Ch.No.	Lower [MHz]	Upper [MHz]
1 ⁸⁾	10755 ⁹⁾	11245 ¹⁰⁾	7	10995	11485
2	10795	11285	8	11035	11525
3	10835	11325	9	11075	11565
4	10875	11365	10	11115	11605
5	10915	11405	11	11155	11645

ver. 1.0 ¹¹⁾

- 1) The respective RAY unit name. The letter “x” stands for “L” or “U” (Lower or Upper band unit).

Example: “RAY11-xA” means both “RAY11-LA” and “RAY11-UA” units. See overview table for details.

Note: The optional last figure in the unit name (e.g. RAY11-LA-2) denotes number of Ethernet ports and it is not relevant for the Nominal frequency tables.

- 2) The respective channel set (nominal frequencies) name in the Ray unit configuration interface (see Configuration, item “Bandwith [MHz]”. In addition to the bandwidth definition, the name may contain additional text which defines the respective alternative of channel plan.

Examples: “Bandwith: 40 MHz (ITU)” means that the nominal frequencies in the table follow the recommendation ITU-R F.387 rec.1.2. for 40 MHz bandwidth, see also the note 5) below.

“Bandwith: 40 MHz (ACMA)” means that the table describes the 40 MHz channel plan defined by ITU-R F.387 rec. 1.1. (b), applied e.g. in Australia.

- 3) The whole frequency range.
- 4) Duplex spacing – the frequency difference between the Upper and Lower channels in a duplex pair.
- 5) The name of standard or recommendation defining the respective channel plan.
- 6) Name of the sub-band defined by channels in the table.
- 7) Name of the “Frequency table” containing the channel set described (see Configuration, item “Frequency tables”).
- 8) The channel number according to RAY unit configuration interface (see Configuration, item “TX channel [GHz]”).
- 9) The nominal TX frequency of the Lower-band channel
- 10) The nominal TX frequency of the Upper-band channel.
- 11) Table version.

9.2. RAY11 A,B parameters

9.2.1. Output power

RAY11-xA, RAY11-xB	TX power	
	Max [dBm]	Min [dBm]
QPSK	23	-5
16-QAM	20	-5
32-QAM	19	-5
64-QAM	18	-5
128-QAM	18	-5
256-QAM	17	-5

ver. 2.0

9.2.2. Radio parameters

RAY11-xA, RAY11-xB		Channel spacing 1.75 MHz; ACCP operation						
Modulation	Raw Bit Rate	User Bit Rate	RSS / SNR for BER 10 ⁻⁶		Co-channel rejection		Adjacent channel Selectivity	
			RSS	SNR	1 dB	3 dB	1 dB	3 dB
					declared / limit	declared / limit	declared / limit	declared / limit
[-]	[Mbps]	[dBm]	[dB]	[dB]	[dB]	[dB]	[dB]	[dB]
QPSK	3.1	2.5	-99	9.5	15 / 23	12 / 19	-12 / 0	-14 / -4
16-QAM	6.3	4.9	-93	15.0	22 / 30	20 / 26.5	-11 / -3	-13 / -7
32-QAM	7.8	6.3	-89	19.0	24 / 30	22 / 26.5	-10 / -3	-12 / -7
64-QAM	9.4	7.4	-88	20.5	29 / 30	26 / 26.5	-9 / -3	-10 / -7
128-QAM	11.0	8.9	-85	23.5	30 / 30	28 / 26.5	-8 / -3	-7 / -7

ver. 2.1

RAY11-xA, RAY11-xB		Channel spacing 3.5 MHz; ACCP operation						
Modulation	Raw Bit Rate	User Bit Rate	RSS / SNR for BER 10 ⁻⁶		Co-channel rejection		Adjacent channel Selectivity	
			RSS	SNR	1 dB	3 dB	1 dB	3 dB
					declared / limit	declared / limit	declared / limit	declared / limit
[-]	[Mbps]	[dBm]	[dB]	[dB]	[dB]	[dB]	[dB]	[dB]
QPSK	6	4.9	-97	9.5	15 / 23	12 / 19	-14 / 0	-16 / -4
16-QAM	12	9.6	-90	15.0	22 / 30	20 / 26.5	-13 / -3	-15 / -7
32-QAM	15	12.1	-87	18.5	24 / 30	22 / 26.5	-12 / -3	-14 / -7
64-QAM	18	14.3	-84	20.5	29 / 30	26 / 26.5	-11 / -3	-12 / -7
128-QAM	21	17.1	-83	23.5	30 / 30	28 / 26.5	-9 / -3	-8 / -7
256-QAM	24	19.7	-81	26.0	33 / 30	31 / 26.5	-5 / -3	-7 / -7

ver. 2.1

RAY11-xA, RAY11-xB		Channel spacing 7 MHz; ACCP operation						
Modulation	Raw Bit Rate	User Bit Rate	RSS / SNR for BER 10 ⁻⁶		Co-channel rejection		Adjacent channel Selectivity	
			RSS	SNR	1 dB	3 dB	1 dB	3 dB
					declared / limit	declared / limit	declared / limit	declared / limit
[-]	[Mbps]	[dBm]	[dB]	[dB]	[dB]	[dB]	[dB]	[dB]
QPSK	12	8.5	-95	8.5	15 / 23	12 / 19	-20 / 0	-22 / -4
16-QAM	24	17.2	-88	15.0	22 / 30	20 / 26.5	-18 / -3	-19 / -7
32-QAM	30	22.1	-85	18.5	24 / 37	22 / 33	-16 / -2	-18 / -6
64-QAM	36	29.7	-81	21.5	29 / 37	26 / 33	-14 / -2	-16 / -6
128-QAM	42	34.7	-78	25.0	32 / 37	30 / 33	-12 / -2	-14 / -6
256-QAM	49	40.7	-77	26.0	33 / 37	31 / 33	-10 / -2	-12 / -6

ver. 2.2

RAY11-xA, RAY11-xB			Channel spacing 14 MHz; ACCP operation					
Modulation	Raw Bit Rate	User Bit Rate	RSS / SNR for BER 10^{-6}		Co-channel rejection		Adjacent channel Selectivity	
					1 dB	3 dB	1 dB	3 dB
			RSS	SNR	declared / limit	declared / limit	declared / limit	declared / limit
[-]	[Mbps]	[dBm]	[dB]	[dB]	[dB]	[dB]	[dB]	
QPSK	24	19.9	-93	8.5	14 / 23	12 / 19	-21 / 0	-23 / -4
16-QAM	48	38.8	-86	15.0	20 / 30	18 / 26.5	-19 / -3	-21 / -7
32-QAM	60	49.1	-82	18.5	26 / 33	23 / 29	-17 / -5	-19 / -9
64-QAM	72	62.3	-79	21.5	28 / 37	26 / 33	-14 / -2	-17 / -6
128-QAM	84	73.6	-75	25.0	30 / 37	28 / 33	-12 / -2	-14 / -6
256-QAM	96	81.2	-72	28.0	33 / 37	31 / 33	-10 / -2	-12 / -6

ver. 2.0

RAY11-xA, RAY11-xB			Channel spacing 28 / 30 MHz; ACCP operation					
Modulation	Raw Bit Rate	User Bit Rate	RSS / SNR for BER 10^{-6}		Co-channel rejection		Adjacent channel Selectivity	
					1 dB	3 dB	1 dB	3 dB
			RSS	SNR	declared / limit	declared / limit	declared / limit	declared / limit
[-]	[Mbps]	[dBm]	[dB]	[dB]	[dB]	[dB]	[dB]	
QPSK	50	36.8	-91	7.5	12 / 23	10 / 19	-21 / 0	-23 / -4
16-QAM	100	80.9	-83	15.0	20 / 30	18 / 26.5	-18 / -3	-20 / -7
32-QAM	125	102.4	-79	18.5	24 / 33	22 / 29	-16 / -5	-19 / -9
64-QAM	150	129.8	-76	21.5	28 / 35	26 / 32	-12 / -5	-15 / -8
128QAM	175	155.5	-72	25.0	30 / 35	28 / 32	-9 / -5	-12 / -8
256-QAM	200	170.7	-70	26.5	33 / 35	31 / 32	-6 / -5	-9 / -8

ver. 2.0

RAY11-xA, RAY11-xB			Channel spacing 28 / 30 MHz; ACAP operation					
Modulation	Raw Bit Rate	User Bit Rate	RSS / SNR for BER 10^{-6}		Co-channel rejection		Adjacent channel Selectivity	
					1 dB	3 dB	1 dB	3 dB
			RSS	SNR	declared / limit	declared / limit	declared / limit	declared / limit
[-]	[Mbps]	[dBm]	[dB]	[dB]	[dB]	[dB]	[dB]	
QPSK	52	38.3	-89.5	7.5	12 / 23	10 / 19	-15 / 0	-17 / -4
16-QAM	104	84.1	-82.5	15.0	20 / 30	18 / 26.5	-12 / -3	-14 / -7
32-QAM	130	106.4	-78.5	18.5	24 / 37	22 / 33	-10 / 3	-13 / -1
64-QAM	156	135.0	-75.5	21.5	28 / 37	26 / 33	-6 / 3	-9 / -1
128QAM	182	161.7	-71.5	25.0	30 / 37	28 / 33	-3 / 3	-6 / -1
256-QAM	208	185.2	-69.5	26.5	33 / 41	31 / 38	0 / 10	-3 / 7

ver. 2.1

RAY11-xA, RAY11-xB					Channel spacing 40 MHz; ACCP operation			
Modulation	Raw Bit Rate	User Bit Rate	RSS / SNR for BER 10 ⁻⁶		Co-channel rejection		Adjacent channel Selectivity	
			RSS	SNR	1 dB	3 dB	1 dB	3 dB
					declared / limit	declared / limit	declared / limit	declared / limit
[-]	[Mbps]	[dBm]	[dB]	[dB]	[dB]	[dB]	[dB]	[dB]
QPSK.	68	50.1	-88	7.5	12 / 33	10 / 29	-22 / -4	-24 / -8
16-QAM	136	110.0	-81	15.0	19 / 33	17 / 29	-18 / -4	-21 / -8
32-QAM	170	139.2	-77	18.5	24 / 33	21 / 29	-16 / -4	-19 / -8
64-QAM	204	176.5	-74	21.5	27 / 33	25 / 29	-14 / -4	-16 / -8
128QAM	238	211.4	-70	25.0	30 / 37	28 / 33	-10 / -4	-12 / -8
256-QAM	272	232.1	-68	26.5	33 / 37	30 / 33	-8 / -4	-10 / -8

ver. 2.0

RAY11-xA, RAY11-xB					Channel spacing 56 MHz; ACCP operation			
Modulation	Raw Bit Rate	User Bit Rate	RSS / SNR for BER 10 ⁻⁶		Co-channel rejection		Adjacent channel Selectivity	
			RSS	SNR	1 dB	3 dB	1 dB	3 dB
					declared / limit	declared / limit	declared / limit	declared / limit
[-]	[Mbps]	[dBm]	[dB]	[dB]	[dB]	[dB]	[dB]	[dB]
QPSK	99	72.9	-87	7.5	12 / 23	10 / 19	-26 / 0	-28 / -4
16-QAM	198	160.2	-80	15.0	19 / 30	17 / 26.5	-19 / -3	-21 / -7
32-QAM	247.5	202.7	-76	18.5	24 / 33	22 / 29	-15 / -5	-17 / -9
64-QAM	297	256.9	-73	21.5	27 / 35	25 / 32	-14 / -5	-16 / -8
128QAM	346.5	303.7	-69	25.0	30 / 35	28 / 32	-10 / -5	-12 / -8
256-QAM	396	337.7	-67	26.5	33 / 35	30 / 32	-8 / -5	-10 / -8

ver. 2.0

RAY11-xA, RAY11-xB					Channel spacing 56 MHz TO; ACCP operation			
Modulation	Raw Bit Rate	User Bit Rate	RSS / SNR for BER 10 ⁻⁶		Co-channel rejection		Adjacent channel Selectivity	
			RSS	SNR	1 dB	3 dB	1 dB	3 dB
					declared / limit	declared / limit	declared / limit	declared / limit
[-]	[Mbps]	[dBm]	[dB]	[dB]	[dB]	[dB]	[dB]	[dB]
QPSK	99	85.8	-85	10.0	13 / 23	11 / 19	-24 / 0	-26 / -4
16-QAM	198	169.9	-78	16.0	20 / 30	18 / 26.5	-18 / -3	-20 / -7
32-QAM	247.5	206.2	-74	19.0	25 / 33	23 / 29	-14 / -5	-15 / -9
64-QAM	297	268.1	-70	22.5	29 / 35	26 / 32	-9 / -5	-11 / -8
128QAM	346.5	309.0	-67	25.5	32 / 35	29 / 32	-8 / -5	-10 / -8
256-QAM	396	358.9	-64	27.5	35 / 35	32 / 32	-7 / -5	-8 / -8

ver. 2.1

9.2.3. Nominal frequencies, duplex 490 MHz

RAy11 – xA , RAY11 – xB			TX channel nominal frequencies								
			Band 10.7 – 11.7 GHz, duplex spacing 490 MHz								
Bandwidth: 1.75 MHz			Channel arrangements based on 28 MHz channels								
A sub-band (Freq.table: rcinfo11_A_490_n)			B sub-band (Freq.table: rcinfo11_B_490_n)								
Ch.No.	Lower [MHz]	Upper [MHz]	Ch.No.	Lower [MHz]	Upper [MHz]	Ch.No.	Lower [MHz]	Upper [MHz]	Ch.No.	Lower [MHz]	Upper [MHz]
1	10709.875	11199.875	74	10837.625	11327.625	136	10946.125	11436.125	205	11066.875	11556.875
2	10711.625	11201.625	75	10839.375	11329.375	137	10947.875	11437.875	206	11068.625	11558.625
3	10713.375	11203.375	76	10841.125	11331.125	138	10949.625	11439.625	207	11070.375	11560.375
4	10715.125	11205.125	77	10842.875	11332.875	139	10951.375	11441.375	208	11072.125	11562.125
5	10716.875	11206.875	78	10844.625	11334.625	140	10953.125	11443.125	209	11073.875	11563.875
6	10718.625	11208.625	79	10846.375	11336.375	141	10954.875	11444.875	210	11075.625	11565.625
7	10720.375	11210.375	80	10848.125	11338.125	142	10956.625	11446.625	211	11077.375	11567.375
8	10722.125	11212.125	81	10849.875	11339.875	143	10958.375	11448.375	212	11079.125	11569.125
9	10723.875	11213.875	82	10851.625	11341.625	144	10960.125	11450.125	213	11080.875	11570.875
10	10725.625	11215.625	83	10853.375	11343.375	145	10961.875	11451.875	214	11082.625	11572.625
11	10727.375	11217.375	84	10855.125	11345.125	146	10963.625	11453.625	215	11084.375	11574.375
12	10729.125	11219.125	85	10856.875	11346.875	147	10965.375	11455.375	216	11086.125	11576.125
13	10730.875	11220.875	86	10858.625	11348.625	148	10967.125	11457.125	217	11087.875	11577.875
14	10732.625	11222.625	87	10860.375	11350.375	149	10968.875	11458.875	218	11089.625	11579.625
15	10734.375	11224.375	88	10862.125	11352.125	150	10970.625	11460.625	219	11091.375	11581.375
16	10736.125	11226.125	89	10863.875	11353.875	151	10972.375	11462.375	220	11093.125	11583.125
17	10737.875	11227.875	90	10865.625	11355.625	152	10974.125	11464.125	221	11094.875	11584.875
18	10739.625	11229.625	91	10867.375	11357.375	153	10975.875	11465.875	222	11096.625	11586.625
19	10741.375	11231.375	92	10869.125	11359.125	154	10977.625	11467.625	223	11098.375	11588.375
20	10743.125	11233.125	93	10870.875	11360.875	155	10979.375	11469.375	224	11100.125	11590.125
21	10744.875	11234.875	94	10872.625	11362.625	156	10981.125	11471.125	225	11101.875	11591.875
22	10746.625	11236.625	95	10874.375	11364.375	157	10982.875	11472.875	226	11103.625	11593.625
23	10748.375	11238.375	96	10876.125	11366.125	158	10984.625	11474.625	227	11105.375	11595.375
24	10750.125	11240.125	97	10877.875	11367.875	159	10986.375	11476.375	228	11107.125	11597.125
25	10751.875	11241.875	98	10879.625	11369.625	160	10988.125	11478.125	229	11108.875	11598.875
26	10753.625	11243.625	99	10881.375	11371.375	161	10989.875	11479.875	230	11110.625	11600.625
27	10755.375	11245.375	100	10883.125	11373.125	162	10991.625	11481.625	231	11112.375	11602.375
28	10757.125	11247.125	101	10884.875	11374.875	163	10993.375	11483.375	232	11114.125	11604.125
29	10758.875	11248.875	102	10886.625	11376.625	164	10995.125	11485.125	233	11115.875	11605.875
30	10760.625	11250.625	103	10888.375	11378.375	165	10996.875	11486.875	234	11117.625	11607.625
31	10762.375	11252.375	104	10890.125	11380.125	166	10998.625	11488.625	235	11119.375	11609.375
32	10764.125	11254.125	105	10891.875	11381.875	167	11000.375	11490.375	236	11121.125	11611.125
33	10765.875	11255.875	106	10893.625	11383.625	168	11002.125	11492.125	237	11122.875	11612.875
34	10767.625	11257.625	107	10895.375	11385.375	169	11003.875	11493.875	238	11124.625	11614.625
35	10769.375	11259.375	108	10897.125	11387.125	170	11005.625	11495.625	239	11126.375	11616.375
36	10771.125	11261.125	109	10898.875	11388.875	171	11007.375	11497.375	240	11128.125	11618.125
37	10772.875	11262.875	110	10900.625	11390.625	172	11009.125	11499.125	241	11129.875	11619.875
38	10774.625	11264.625	111	10902.375	11392.375	173	11010.875	11500.875	242	11131.625	11621.625
39	10776.375	11266.375	112	10904.125	11394.125	174	11012.625	11502.625	243	11133.375	11623.375
40	10778.125	11268.125	113	10905.875	11395.875	175	11014.375	11504.375	244	11135.125	11625.125
41	10779.875	11269.875	114	10907.625	11397.625	176	11016.125	11506.125	245	11136.875	11626.875
42	10781.625	11271.625	115	10909.375	11399.375	177	11017.875	11507.875	246	11138.625	11628.625
43	10783.375	11273.375	116	10911.125	11401.125	178	11019.625	11509.625	247	11140.375	11630.375
44	10785.125	11275.125	117	10912.875	11402.875	179	11021.375	11511.375	248	11142.125	11632.125
45	10786.875	11276.875	118	10914.625	11404.625	180	11023.125	11513.125	249	11143.875	11633.875
46	10788.625	11278.625	119	10916.375	11406.375	181	11024.875	11514.875	250	11145.625	11635.625
47	10790.375	11280.375	120	10918.125	11408.125	182	11026.625	11516.625	251	11147.375	11637.375
48	10792.125	11282.125	121	10919.875	11409.875	183	11028.375	11518.375	252	11149.125	11639.125
49	10793.875	11283.875	122	10921.625	11411.625	184	11030.125	11520.125	253	11150.875	11640.875
50	10795.625	11285.625	123	10923.375	11413.375	185	11031.875	11521.875	254	11152.625	11642.625
51	10797.375	11287.375	124	10925.125	11415.125	186	11033.625	11523.625	255	11154.375	11644.375
52	10799.125	11289.125	125	10926.875	11416.875	187	11035.375	11525.375	256	11156.125	11646.125
53	10800.875	11290.875	126	10928.625	11418.625	188	11037.125	11527.125	257	11157.875	11647.875
54	10802.625	11292.625	127	10930.375	11420.375	189	11038.875	11528.875	258	11159.625	11649.625
55	10804.375	11294.375	128	10932.125	11422.125	190	11040.625	11530.625	259	11161.375	11651.375
56	10806.125	11296.125	129	10933.875	11423.875	191	11042.375	11532.375	260	11163.125	11653.125
57	10807.875	11297.875	130	10935.625	11425.625	192	11044.125	11534.125	261	11164.875	11654.875
58	10809.625	11299.625	131	10937.375	11427.375	193	11045.875	11535.875	262	11166.625	11656.625
59	10811.375	11301.375	132	10939.125	11429.125	194	11047.625	11537.625	263	11168.375	11658.375
60	10813.125	11303.125	133	10940.875	11430.875	195	11049.375	11539.375	264	11170.125	11660.125
61	10814.875	11304.875	134	10942.625	11432.625	196	11051.125	11541.125	265	11171.875	11661.875
62	10816.625	11306.625	135	10944.375	11434.375	197	11052.875	11542.875	266	11173.625	11663.625
63	10818.375	11308.375	136	10946.125	11436.125	198	11054.625	11544.625	267	11175.375	11665.375
64	10820.125	11310.125	137	10947.875	11437.875	199	11056.375	11546.375	268	11177.125	11667.125
65	10821.875	11311.875	138	10949.625	11439.625	200	11058.125	11548.125	269	11178.875	11668.875
66	10823.625	11313.625	139	10951.375	11441.375	201	11059.875	11549.875	270	11180.625	11670.625
67	10825.375	11315.375	140	10953.125	11443.125	202	11061.625	11551.625	271	11182.375	11672.375
68	10827.125	11317.125	141	10954.875	11444.875	203	11063.375	11553.375	272	11184.125	11674.125
69	10828.875	11318.875	142	10956.625	11446.625	204	11065.125	11555.125			
70	10830.625	11320.625	143	10958.375	11448.375						
71	10832.375	11322.375	144	10960.125	11450.125						
72	10834.125	11324.125	145	10961.875	11451.875						
73	10835.875	11325.875	146	10963.625	11453.625						

ver. 2.1

RAy11 – xA , RAY11 – xB			TX channel nominal frequencies								
			Band 10.7 – 11.7 GHz, duplex spacing 490 MHz								
Bandwidth: 3.5 MHz			Channel arrangements based on 28 MHz channels								
A sub-band (Freq.table: rcinfo11_A_490, rcinfo11_A_490_n)			B sub-band (Freq.table: rcinfo11_B_490, rcinfo11_B_490_n)								
Ch.No.	Lower [MHz]	Upper [MHz]	Ch.No.	Lower [MHz]	Upper [MHz]	Ch.No.	Lower [MHz]	Upper [MHz]	Ch.No.	Lower [MHz]	Upper [MHz]
1	10710.75	11200.75	38	10840.25	11330.25	69	10948.75	11438.75	103	11067.75	11557.75
2	10714.25	11204.25	39	10843.75	11333.75	70	10952.25	11442.25	104	11071.25	11561.25
3	10717.75	11207.75	40	10847.25	11337.25	71	10955.75	11445.75	105	11074.75	11564.75
4	10721.25	11211.25	41	10850.75	11340.75	72	10959.25	11449.25	106	11078.25	11568.25
5	10724.75	11214.75	42	10854.25	11344.25	73	10962.75	11452.75	107	11081.75	11571.75
6	10728.25	11218.25	43	10857.75	11347.75	74	10966.25	11456.25	108	11085.25	11575.25
7	10731.75	11221.75	44	10861.25	11351.25	75	10969.75	11459.75	109	11088.75	11578.75
8	10735.25	11225.25	45	10864.75	11354.75	76	10973.25	11463.25	110	11092.25	11582.25
9	10738.75	11228.75	46	10868.25	11358.25	77	10976.75	11466.75	111	11095.75	11585.75
10	10742.25	11232.25	47	10871.75	11361.75	78	10980.25	11470.25	112	11099.25	11589.25
11	10745.75	11235.75	48	10875.25	11365.25	79	10983.75	11473.75	113	11102.75	11592.75
12	10749.25	11239.25	49	10878.75	11368.75	80	10987.25	11477.25	114	11106.25	11596.25
13	10752.75	11242.75	50	10882.25	11372.25	81	10990.75	11480.75	115	11109.75	11599.75
14	10756.25	11246.25	51	10885.75	11375.75	82	10994.25	11484.25	116	11113.25	11603.25
15	10759.75	11249.75	52	10889.25	11379.25	83	10997.75	11487.75	117	11116.75	11606.75
16	10763.25	11253.25	53	10892.75	11382.75	84	11001.25	11491.25	118	11120.25	11610.25
17	10766.75	11256.75	54	10896.25	11386.25	85	11004.75	11494.75	119	11123.75	11613.75
18	10770.25	11260.25	55	10899.75	11389.75	86	11008.25	11498.25	120	11127.25	11617.25
19	10773.75	11263.75	56	10903.25	11393.25	87	11011.75	11501.75	121	11130.75	11620.75
20	10777.25	11267.25	57	10906.75	11396.75	88	11015.25	11505.25	122	11134.25	11624.25
21	10780.75	11270.75	58	10910.25	11400.25	89	11018.75	11508.75	123	11137.75	11627.75
22	10784.25	11274.25	59	10913.75	11403.75	90	11022.25	11512.25	124	11141.25	11631.25
23	10787.75	11277.75	60	10917.25	11407.25	91	11025.75	11515.75	125	11144.75	11634.75
24	10791.25	11281.25	61	10920.75	11410.75	92	11029.25	11519.25	126	11148.25	11638.25
25	10794.75	11284.75	62	10924.25	11414.25	93	11032.75	11522.75	127	11151.75	11641.75
26	10798.25	11288.25	63	10927.75	11417.75	94	11036.25	11526.25	128	11155.25	11645.25
27	10801.75	11291.75	64	10931.25	11421.25	95	11039.75	11529.75	129	11158.75	11648.75
28	10805.25	11295.25	65	10934.75	11424.75	96	11043.25	11533.25	130	11162.25	11652.25
29	10808.75	11298.75	66	10938.25	11428.25	97	11046.75	11536.75	131	11165.75	11655.75
30	10812.25	11302.25	67	10941.75	11431.75	98	11050.25	11540.25	132	11169.25	11659.25
31	10815.75	11305.75	68	10945.25	11435.25	99	11053.75	11543.75	133	11172.75	11662.75
32	10819.25	11309.25	69	10948.75	11438.75	100	11057.25	11547.25	134	11176.25	11666.25
33	10822.75	11312.75	70	10952.25	11442.25	101	11060.75	11550.75	135	11179.75	11669.75
34	10826.25	11316.25	71	10955.75	11445.75	102	11064.25	11554.25	136	11183.25	11673.25
35	10829.75	11319.75	72	10959.25	11449.25						
36	10833.25	11323.25	73	10962.75	11452.75						
37	10836.75	11326.75									

ver. 2.1

RAy11 – xA , RAY11 – xB			TX channel nominal frequencies		
Bandwidth: 7 MHz			Band 10.7 – 11.7 GHz, duplex spacing 490 MHz		
Channel arrangements based on 28 MHz channels					
A sub-band (Freq.table: rcinfo11_A_490, rcinfo11_A_490_n)			B sub-band (Freq.table: rcinfo11_B_490, rcinfo11_B_490_n)		
Ch.No.	Lower [MHz]	Upper [MHz]	Ch.No.	Lower [MHz]	Upper [MHz]
1	10712.5	11202.5	35	10950.5	11440.5
2	10719.5	11209.5	36	10957.5	11447.5
3	10726.5	11216.5	37	10964.5	11454.5
4	10733.5	11223.5	38	10971.5	11461.5
5	10740.5	11230.5	39	10978.5	11468.5
6	10747.5	11237.5	40	10985.5	11475.5
7	10754.5	11244.5	41	10992.5	11482.5
8	10761.5	11251.5	42	10999.5	11489.5
9	10768.5	11258.5	43	11006.5	11496.5
10	10775.5	11265.5	44	11013.5	11503.5
11	10782.5	11272.5	45	11020.5	11510.5
12	10789.5	11279.5	46	11027.5	11517.5
13	10796.5	11286.5	47	11034.5	11524.5
14	10803.5	11293.5	48	11041.5	11531.5
15	10810.5	11300.5	49	11048.5	11538.5
16	10817.5	11307.5	50	11055.5	11545.5
17	10824.5	11314.5	51	11062.5	11552.5
18	10831.5	11321.5	52	11069.5	11559.5
19	10838.5	11328.5	53	11076.5	11566.5
20	10845.5	11335.5	54	11083.5	11573.5
21	10852.5	11342.5	55	11090.5	11580.5
22	10859.5	11349.5	56	11097.5	11587.5
23	10866.5	11356.5	57	11104.5	11594.5
24	10873.5	11363.5	58	11111.5	11601.5
25	10880.5	11370.5	59	11118.5	11608.5
26	10887.5	11377.5	60	11125.5	11615.5
27	10894.5	11384.5	61	11132.5	11622.5
28	10901.5	11391.5	62	11139.5	11629.5
29	10908.5	11398.5	63	11146.5	11636.5
30	10915.5	11405.5	64	11153.5	11643.5
31	10922.5	11412.5	65	11160.5	11650.5
32	10929.5	11419.5	66	11167.5	11657.5
33	10936.5	11426.5	67	11174.5	11664.5
34	10943.5	11433.5	68	11181.5	11671.5
35	10950.5	11440.5			
36	10957.5	11447.5			

ver. 2.1

RAy11 – xA , RAy11 – xB			TX channel nominal frequencies		
Bandwidth: 14 MHz			Band 10.7 – 11.7 GHz, duplex spacing 490 MHz		
A sub-band (Freq.table: rcinfo11_A_490, rcinfo11_A_490_n)			B sub-band (Freq.table: rcinfo11_B_490, rcinfo11_B_490_n)		
Ch.No.	Lower [MHz]	Upper [MHz]	Ch.No.	Lower [MHz]	Upper [MHz]
1	10716	11206	19	10968	11458
2	10730	11220	20	10982	11472
3	10744	11234	21	10996	11486
4	10758	11248	22	11010	11500
5	10772	11262	23	11024	11514
6	10786	11276	24	11038	11528
7	10800	11290	25	11052	11542
8	10814	11304	26	11066	11556
9	10828	11318	27	11080	11570
10	10842	11332	28	11094	11584
11	10856	11346	29	11108	11598
12	10870	11360	30	11122	11612
13	10884	11374	31	11136	11626
14	10898	11388	32	11150	11640
15	10912	11402	33	11164	11654
16	10926	11416	34	11178	11668
17	10940	11430			
18	10954	11444			

ver. 2.1

RAy11 – xA , RAy11 – xB			TX channel nominal frequencies		
Bandwidth: 28 MHz			Band 10.7 – 11.7 GHz, duplex spacing 490 MHz		
A sub-band (Freq.table: rcinfo11_A_490, rcinfo11_A_490_n)			B sub-band (Freq.table: rcinfo11_B_490, rcinfo11_B_490_n)		
Ch.No.	Lower [MHz]	Upper [MHz]	Ch.No.	Lower [MHz]	Upper [MHz]
1	10723	11213	10	10975	11465
2	10751	11241	11	11003	11493
3	10779	11269	12	11031	11521
4	10807	11297	13	11059	11549
5	10835	11325	14	11087	11577
6	10863	11353	15	11115	11605
7	10891	11381	16	11143	11633
8	10919	11409	17	11171	11661
9	10947	11437			

ver. 2.1

RAy11 – xA , RAY11 – xB			TX channel nominal frequencies		
Bandwidth: 30 MHz			Band 10.7 – 11.7 GHz, duplex spacing 490 MHz		
IC					
A sub-band (Freq.table: rcinfo11_A_490, rcinfo11_A_490_n)			B sub-band (Freq.table: rcinfo11_B_490, rcinfo11_B_490_n)		
Ch.No.	Lower [MHz]	Upper [MHz]	Ch.No.	Lower [MHz]	Upper [MHz]
1	10725	11215	9	10965	11455
2	10755	11245	10	10995	11485
3	10785	11275	11	11025	11515
4	10815	11305	12	11055	11545
5	10845	11335	13	11085	11575
6	10875	11365	14	11115	11605
7	10905	11395	15	11145	11635
8	10935	11425	16	11175	11665

ver. 1.0

RAy11 – xA , RAY11 – xB			TX channel nominal frequencies		
Bandwidth: 40 MHz (ITU)			Band 10.7 – 11.7 GHz, duplex spacing 490 MHz		
ITU-R F.387 rec.1.2, CEPT 12-06 Annex B.1					
A sub-band (Freq.table: rcinfo11_A_490, rcinfo11_A_490_n)			B sub-band (Freq.table: rcinfo11_B_490, rcinfo11_B_490_n)		
Ch.No.	Lower [MHz]	Upper [MHz]	Ch.No.	Lower [MHz]	Upper [MHz]
1	10735	11225	7	10975	11465
2	10775	11265	8	11015	11505
3	10815	11305	9	11055	11545
4	10855	11345	10	11095	11585
5	10895	11385	11	11135	11625
6	10935	11425	12	11175	11665

ver. 1.0

RAy11 – xA , RAY11 – xB			TX channel nominal frequencies		
Bandwidth: 40 MHz (ACMA)			Band 10.7 – 11.7 GHz, duplex spacing 490 MHz		
ITU-R F.387 rec. 1.1 (b)					
A sub-band (Freq.table: rcinfo11_A_490, rcinfo11_A_490_n)			B sub-band (Freq.table: rcinfo11_B_490, rcinfo11_B_490_n)		
Ch.No.	Lower [MHz]	Upper [MHz]	Ch.No.	Lower [MHz]	Upper [MHz]
1	10715	11205	8	10995	11485
2	10755	11245	9	11035	11525
3	10795	11285	10	11075	11565
4	10835	11325	11	11115	11605
5	10875	11365	12	11155	11645
6	10915	11405			

ver. 1.0

RAy11 – xA , RAY11 – xB			TX channel nominal frequencies		
Bandwidth: 56 MHz			Band 10.7 – 11.7 GHz, duplex spacing 490 MHz		
CEPT 12-06, Annex C					
A sub-band (Freq.table: rcinfo11_A_490, rcinfo11_A_490_n)			B sub-band (Freq.table: rcinfo11_B_490, rcinfo11_B_490_n)		
Ch.No.	Lower [MHz]	Upper [MHz]	Ch.No.	Lower [MHz]	Upper [MHz]
1	10737	11227	10	10989	11479
2	10765	11255	11	11017	11507
3	10793	11283	12	11045	11535
4	10821	11311	13	11073	11563
5	10849	11339	14	11101	11591
6	10877	11367	15	11129	11619
7	10905	11395	16	11157	11647
8	10933	11423			

ver. 2.1

RAy11 – xA , RAY11 – xB			TX channel nominal frequencies		
Bandwidth: 56 MHz (CS 80)			Band 10.7 – 11.7 GHz, duplex spacing 490 MHz		
CEPT 12-06 Annex C					
A sub-band (Freq.table: rcinfo11_A_490, rcinfo11_A_490_n)			B sub-band (Freq.table: rcinfo11_B_490, rcinfo11_B_490_n)		
Ch.No.	Lower [MHz]	Upper [MHz]	Ch.No.	Lower [MHz]	Upper [MHz]
1	10755	11245	7	10995	11485
2	10795	11285	8	11035	11525
3	10835	11325	9	11075	11565
4	10875	11365	10	11115	11605
5	10915	11405	11	11155	11645

ver. 1.0

9.2.4. Nominal frequencies, duplex 530 MHz

RAY11 – xA , RAY11 – xB			TX channel nominal frequencies								
			Band 10.7 – 11.7 GHz, duplex spacing 530 MHz								
Bandwidth: 1.75 MHz			Channel arrangements based on 7 MHz channels								
A sub-band (Freq.table: rcinfo11_A_530_n)			B sub-band (Freq.table: rcinfo11_B_530_n)								
Ch.No.	Lower [MHz]	Upper [MHz]	Ch.No.	Lower [MHz]	Upper [MHz]	Ch.No.	Lower [MHz]	Upper [MHz]	Ch.No.	Lower [MHz]	Upper [MHz]
1	10709.875	11239.875	64	10820.125	11350.125	136	10946.125	11476.125	199	11056.375	11586.375
2	10711.625	11241.625	65	10821.875	11351.875	137	10947.875	11477.875	200	11058.125	11588.125
3	10713.375	11243.375	66	10823.625	11353.625	138	10949.625	11479.625	201	11059.875	11589.875
4	10715.125	11245.125	67	10825.375	11355.375	139	10951.375	11481.375	202	11061.625	11591.625
5	10716.875	11246.875	68	10827.125	11357.125	140	10953.125	11483.125	203	11063.375	11593.375
6	10718.625	11248.625	69	10828.875	11358.875	141	10954.875	11484.875	204	11065.125	11595.125
7	10720.375	11250.375	70	10830.625	11360.625	142	10956.625	11486.625	205	11066.875	11596.875
8	10722.125	11252.125	71	10832.375	11362.375	143	10958.375	11488.375	206	11068.625	11598.625
9	10723.875	11253.875	72	10834.125	11364.125	144	10960.125	11490.125	207	11070.375	11600.375
10	10725.625	11255.625	73	10835.875	11365.875	145	10961.875	11491.875	208	11072.125	11602.125
11	10727.375	11257.375	74	10837.625	11367.625	146	10963.625	11493.625	209	11073.875	11603.875
12	10729.125	11259.125	75	10839.375	11369.375	147	10965.375	11495.375	210	11075.625	11605.625
13	10730.875	11260.875	76	10841.125	11371.125	148	10967.125	11497.125	211	11077.375	11607.375
14	10732.625	11262.625	77	10842.875	11372.875	149	10968.875	11498.875	212	11079.125	11609.125
15	10734.375	11264.375	78	10844.625	11374.625	150	10970.625	11500.625	213	11080.875	11610.875
16	10736.125	11266.125	79	10846.375	11376.375	151	10972.375	11502.375	214	11082.625	11612.625
17	10737.875	11267.875	80	10848.125	11378.125	152	10974.125	11504.125	215	11084.375	11614.375
18	10739.625	11269.625	81	10849.875	11379.875	153	10975.875	11505.875	216	11086.125	11616.125
19	10741.375	11271.375	82	10851.625	11381.625	154	10977.625	11507.625	217	11087.875	11617.875
20	10743.125	11273.125	83	10853.375	11383.375	155	10979.375	11509.375	218	11089.625	11619.625
21	10744.875	11274.875	84	10855.125	11385.125	156	10981.125	11511.125	219	11091.375	11621.375
22	10746.625	11276.625	85	10856.875	11386.875	157	10982.875	11512.875	220	11093.125	11623.125
23	10748.375	11278.375	86	10858.625	11388.625	158	10984.625	11514.625	221	11094.875	11624.875
24	10750.125	11280.125	87	10860.375	11390.375	159	10986.375	11516.375	222	11096.625	11626.625
25	10751.875	11281.875	88	10862.125	11392.125	160	10988.125	11518.125	223	11098.375	11628.375
26	10753.625	11283.625	89	10863.875	11393.875	161	10989.875	11519.875	224	11100.125	11630.125
27	10755.375	11285.375	90	10865.625	11395.625	162	10991.625	11521.625	225	11101.875	11631.875
28	10757.125	11287.125	91	10867.375	11397.375	163	10993.375	11523.375	226	11103.625	11633.625
29	10758.875	11288.875	92	10869.125	11399.125	164	10995.125	11525.125	227	11105.375	11635.375
30	10760.625	11290.625	93	10870.875	11400.875	165	10996.875	11526.875	228	11107.125	11637.125
31	10762.375	11292.375	94	10872.625	11402.625	166	10998.625	11528.625	229	11108.875	11638.875
32	10764.125	11294.125	95	10874.375	11404.375	167	11000.375	11530.375	230	11110.625	11640.625
33	10765.875	11295.875	96	10876.125	11406.125	168	11002.125	11532.125	231	11112.375	11642.375
34	10767.625	11297.625	97	10877.875	11407.875	169	11003.875	11533.875	232	11114.125	11644.125
35	10769.375	11299.375	98	10879.625	11409.625	170	11005.625	11535.625	233	11115.875	11645.875
36	10771.125	11301.125	99	10881.375	11411.375	171	11007.375	11537.375	234	11117.625	11647.625
37	10772.875	11302.875	100	10883.125	11413.125	172	11009.125	11539.125	235	11119.375	11649.375
38	10774.625	11304.625	101	10884.875	11414.875	173	11010.875	11540.875	236	11121.125	11651.125
39	10776.375	11306.375	102	10886.625	11416.625	174	11012.625	11542.625	237	11122.875	11652.875
40	10778.125	11308.125	103	10888.375	11418.375	175	11014.375	11544.375	238	11124.625	11654.625
41	10779.875	11309.875	104	10890.125	11420.125	176	11016.125	11546.125	239	11126.375	11656.375
42	10781.625	11311.625	105	10891.875	11421.875	177	11017.875	11547.875	240	11128.125	11658.125
43	10783.375	11313.375	106	10893.625	11423.625	178	11019.625	11549.625	241	11129.875	11659.875
44	10785.125	11315.125	107	10895.375	11425.375	179	11021.375	11551.375	242	11131.625	11661.625
45	10786.875	11316.875	108	10897.125	11427.125	180	11023.125	11553.125	243	11133.375	11663.375
46	10788.625	11318.625	109	10898.875	11428.875	181	11024.875	11554.875	244	11135.125	11665.125
47	10790.375	11320.375	110	10900.625	11430.625	182	11026.625	11556.625	245	11136.875	11666.875
48	10792.125	11322.125	111	10902.375	11432.375	183	11028.375	11558.375	246	11138.625	11668.625
49	10793.875	11323.875	112	10904.125	11434.125	184	11030.125	11560.125	247	11140.375	11670.375
50	10795.625	11325.625	113	10905.875	11435.875	185	11031.875	11561.875	248	11142.125	11672.125
51	10797.375	11327.375	114	10907.625	11437.625	186	11033.625	11563.625	249	11143.875	11673.875
52	10799.125	11329.125	115	10909.375	11439.375	187	11035.375	11565.375	250	11145.625	11675.625
53	10800.875	11330.875	116	10911.125	11441.125	188	11037.125	11567.125	251	11147.375	11677.375
54	10802.625	11332.625	117	10912.875	11442.875	189	11038.875	11568.875	252	11149.125	11679.125
55	10804.375	11334.375	118	10914.625	11444.625	190	11040.625	11570.625	253	11150.875	11680.875
56	10806.125	11336.125	119	10916.375	11446.375	191	11042.375	11572.375	254	11152.625	11682.625
57	10807.875	11337.875	120	10918.125	11448.125	192	11044.125	11574.125	255	11154.375	11684.375
58	10809.625	11339.625	121	10919.875	11449.875	193	11045.875	11575.875	256	11156.125	11686.125
59	10811.375	11341.375	122	10921.625	11451.625	194	11047.625	11577.625	257	11157.875	11687.875
60	10813.125	11343.125	123	10923.375	11453.375	195	11049.375	11579.375	258	11159.625	11689.625
61	10814.875	11344.875	124	10925.125	11455.125	196	11051.125	11581.125	259	11161.375	11691.375
62	10816.625	11346.625	125	10926.875	11456.875	197	11052.875	11582.875	260	11163.125	11693.125
63	10818.375	11348.375				198	11054.625	11584.625			

ver. 2.1

RAy11 – xA , RAY11 – xB			TX channel nominal frequencies								
			Band 10.7 – 11.7 GHz, duplex spacing 530 MHz								
Bandwidth: 3.5 MHz			Channel arrangements based on 7 MHz channels								
A sub-band (Freq.table: rcinfo11_A_530, rcinfo11_A_530_n)			B sub-band (Freq.table: rcinfo11_B_530, rcinfo11_B_530_n)								
Ch.No.	Lower [MHz]	Upper [MHz]	Ch.No.	Lower [MHz]	Upper [MHz]	Ch.No.	Lower [MHz]	Upper [MHz]	Ch.No.	Lower [MHz]	Upper [MHz]
1	10710.75	11240.75	32	10819.25	11349.25	69	10948.75	11478.75	100	11057.25	11587.25
2	10714.25	11244.25	33	10822.75	11352.75	70	10952.25	11482.25	101	11060.75	11590.75
3	10717.75	11247.75	34	10826.25	11356.25	71	10955.75	11485.75	102	11064.25	11594.25
4	10721.25	11251.25	35	10829.75	11359.75	72	10959.25	11489.25	103	11067.75	11597.75
5	10724.75	11254.75	36	10833.25	11363.25	73	10962.75	11492.75	104	11071.25	11601.25
6	10728.25	11258.25	37	10836.75	11366.75	74	10966.25	11496.25	105	11074.75	11604.75
7	10731.75	11261.75	38	10840.25	11370.25	75	10969.75	11499.75	106	11078.25	11608.25
8	10735.25	11265.25	39	10843.75	11373.75	76	10973.25	11503.25	107	11081.75	11611.75
9	10738.75	11268.75	40	10847.25	11377.25	77	10976.75	11506.75	108	11085.25	11615.25
10	10742.25	11272.25	41	10850.75	11380.75	78	10980.25	11510.25	109	11088.75	11618.75
11	10745.75	11275.75	42	10854.25	11384.25	79	10983.75	11513.75	110	11092.25	11622.25
12	10749.25	11279.25	43	10857.75	11387.75	80	10987.25	11517.25	111	11095.75	11625.75
13	10752.75	11282.75	44	10861.25	11391.25	81	10990.75	11520.75	112	11099.25	11629.25
14	10756.25	11286.25	45	10864.75	11394.75	82	10994.25	11524.25	113	11102.75	11632.75
15	10759.75	11289.75	46	10868.25	11398.25	83	10997.75	11527.75	114	11106.25	11636.25
16	10763.25	11293.25	47	10871.75	11401.75	84	11001.25	11531.25	115	11109.75	11639.75
17	10766.75	11296.75	48	10875.25	11405.25	85	11004.75	11534.75	116	11113.25	11643.25
18	10770.25	11300.25	49	10878.75	11408.75	86	11008.25	11538.25	117	11116.75	11646.75
19	10773.75	11303.75	50	10882.25	11412.25	87	11011.75	11541.75	118	11120.25	11650.25
20	10777.25	11307.25	51	10885.75	11415.75	88	11015.25	11545.25	119	11123.75	11653.75
21	10780.75	11310.75	52	10889.25	11419.25	89	11018.75	11548.75	120	11127.25	11657.25
22	10784.25	11314.25	53	10892.75	11422.75	90	11022.25	11552.25	121	11130.75	11660.75
23	10787.75	11317.75	54	10896.25	11426.25	91	11025.75	11555.75	122	11134.25	11664.25
24	10791.25	11321.25	55	10899.75	11429.75	92	11029.25	11559.25	123	11137.75	11667.75
25	10794.75	11324.75	56	10903.25	11433.25	93	11032.75	11562.75	124	11141.25	11671.25
26	10798.25	11328.25	57	10906.75	11436.75	94	11036.25	11566.25	125	11144.75	11674.75
27	10801.75	11331.75	58	10910.25	11440.25	95	11039.75	11569.75	126	11148.25	11678.25
28	10805.25	11335.25	59	10913.75	11443.75	96	11043.25	11573.25	127	11151.75	11681.75
29	10808.75	11338.75	60	10917.25	11447.25	97	11046.75	11576.75	128	11155.25	11685.25
30	10812.25	11342.25	61	10920.75	11450.75	98	11050.25	11580.25	129	11158.75	11688.75
31	10815.75	11345.75	62	10924.25	11454.25	99	11053.75	11583.75	130	11162.25	11692.25

ver. 2.1

RAy11 – xA , RAY11 – xB			TX channel nominal frequencies		
Bandwidth: 7 MHz			Band 10.7 – 11.7 GHz, duplex spacing 530 MHz		
ITU-R F.387 , Annex 5					
A sub-band (Freq.table: rcinfo11_A_530, rcinfo11_A_530_n)			B sub-band (Freq.table: rcinfo11_B_530, rcinfo11_B_530_n)		
Ch.No.	Lower [MHz]	Upper [MHz]	Ch.No.	Lower [MHz]	Upper [MHz]
1	10712.5	11242.5	35	10950.5	11480.5
2	10719.5	11249.5	36	10957.5	11487.5
3	10726.5	11256.5	37	10964.5	11494.5
4	10733.5	11263.5	38	10971.5	11501.5
5	10740.5	11270.5	39	10978.5	11508.5
6	10747.5	11277.5	40	10985.5	11515.5
7	10754.5	11284.5	41	10992.5	11522.5
8	10761.5	11291.5	42	10999.5	11529.5
9	10768.5	11298.5	43	11006.5	11536.5
10	10775.5	11305.5	44	11013.5	11543.5
11	10782.5	11312.5	45	11020.5	11550.5
12	10789.5	11319.5	46	11027.5	11557.5
13	10796.5	11326.5	47	11034.5	11564.5
14	10803.5	11333.5	48	11041.5	11571.5
15	10810.5	11340.5	49	11048.5	11578.5
16	10817.5	11347.5	50	11055.5	11585.5
17	10824.5	11354.5	51	11062.5	11592.5
18	10831.5	11361.5	52	11069.5	11599.5
19	10838.5	11368.5	53	11076.5	11606.5
20	10845.5	11375.5	54	11083.5	11613.5
21	10852.5	11382.5	55	11090.5	11620.5
22	10859.5	11389.5	56	11097.5	11627.5
23	10866.5	11396.5	57	11104.5	11634.5
24	10873.5	11403.5	58	11111.5	11641.5
25	10880.5	11410.5	59	11118.5	11648.5
26	10887.5	11417.5	60	11125.5	11655.5
27	10894.5	11424.5	61	11132.5	11662.5
28	10901.5	11431.5	62	11139.5	11669.5
29	10908.5	11438.5	63	11146.5	11676.5
30	10915.5	11445.5	64	11153.5	11683.5
31	10922.5	11452.5	65	11160.5	11690.5

ver. 2.1

RAy11 – xA , RAY11 – xB			TX channel nominal frequencies		
Bandwidth: 14 MHz			Band 10.7 – 11.7 GHz, duplex spacing 530 MHz		
ITU-R F.387 , Annex 5					
A sub-band (Freq.table: rcinfo11_A_530, rcinfo11_A_530_n)			B sub-band (Freq.table: rcinfo11_B_530, rcinfo11_B_530_n)		
Ch.No.	Lower [MHz]	Upper [MHz]	Ch.No.	Lower [MHz]	Upper [MHz]
1	10716	11246	18	10954	11484
2	10730	11260	19	10968	11498
3	10744	11274	20	10982	11512
4	10758	11288	21	10996	11526
5	10772	11302	22	11010	11540
6	10786	11316	23	11024	11554
7	10800	11330	24	11038	11568
8	10814	11344	25	11052	11582
9	10828	11358	26	11066	11596
10	10842	11372	27	11080	11610
11	10856	11386	28	11094	11624
12	10870	11400	29	11108	11638
13	10884	11414	30	11122	11652
14	10898	11428	31	11136	11666
15	10912	11442	32	11150	11680

ver. 2.1

RAy11 – xA , RAY11 – xB			TX channel nominal frequencies		
Bandwidth: 28 MHz			Band 10.7 – 11.7 GHz, duplex spacing 530 MHz		
ITU-R F.387 , Annex 5					
A sub-band (Freq.table: rcinfo11_A_530, rcinfo11_A_530_n)			B sub-band (Freq.table: rcinfo11_B_530, rcinfo11_B_530_n)		
Ch.No.	Lower [MHz]	Upper [MHz]	Ch.No.	Lower [MHz]	Upper [MHz]
1	10723	11253	10	10975	11505
2	10751	11281	11	11003	11533
3	10779	11309	12	11031	11561
4	10807	11337	13	11059	11589
5	10835	11365	14	11087	11617
6	10863	11393	15	11115	11645
7	10891	11421	16	11143	11673

ver. 2.1

RAy11 – xA , RAY11 – xB			TX channel nominal frequencies		
Bandwidth: 40 MHz (ITU)			Band 10.7 – 11.7 GHz, duplex spacing 530 MHz		
ITU-R F.387 , rec. 1.1					
A sub-band (Freq.table: rcinfo11_A_530, rcinfo11_A_530_n)			B sub-band (Freq.table: rcinfo11_B_530, rcinfo11_B_530_n)		
Ch.No.	Lower [MHz]	Upper [MHz]	Ch.No.	Lower [MHz]	Upper [MHz]
1	10715	11245	8	10995	11525
2	10755	11285	9	11035	11565
3	10795	11325	10	11075	11605
4	10835	11365	11	11115	11645
5	10875	11405	12	11155	11685

ver. 1.0

RAy11 – xA , RAY11 – xB			TX channel nominal frequencies		
Bandwidth: 40 MHz (CEPT)			Band 10.7 – 11.7 GHz, duplex spacing 530 MHz		
CEPT 12-06, Annex A.1					
A sub-band (Freq.table: rcinfo11_A_530, rcinfo11_A_530_n)			B sub-band (Freq.table: rcinfo11_B_530, rcinfo11_B_530_n)		
Ch.No.	Lower [MHz]	Upper [MHz]	Ch.No.	Lower [MHz]	Upper [MHz]
1	10735	11265	7	10975	11505
2	10775	11305	8	11015	11545
3	10815	11345	9	11055	11585
4	10855	11385	10	11095	11625
5	10895	11425	11	11135	11665

ver. 1.0

RAy11 – xA , RAY11 – xB			TX channel nominal frequencies		
Bandwidth: 56 MHz			Band 10.7 – 11.7 GHz, duplex spacing 530 MHz		
CEPT 12-06, Annex C					
A sub-band (Freq.table: rcinfo11_A_530, rcinfo11_A_530_n)			B sub-band (Freq.table: rcinfo11_B_530, rcinfo11_B_530_n)		
Ch.No.	Lower [MHz]	Upper [MHz]	Ch.No.	Lower [MHz]	Upper [MHz]
1	10737	11267	10	10989	11519
2	10765	11295	11	11017	11547
3	10793	11323	12	11045	11575
4	10821	11351	13	11073	11603
5	10849	11379	14	11101	11631
6	10877	11407	15	11129	11659

ver. 2.1

RAy11 – xA , RAY11 – xB			TX channel nominal frequencies		
Bandwidth: 56 MHz (CS 80)			Band 10.7 – 11.7 GHz, duplex spacing 530 MHz		
CEPT 12-06, Annex C					
A sub-band (Freq.table: rcinfo11_A_530, rcinfo11_A_530_n)			B sub-band (Freq.table: rcinfo11_B_530, rcinfo11_B_530_n)		
Ch.No.	Lower [MHz]	Upper [MHz]	Ch.No.	Lower [MHz]	Upper [MHz]
1	10755	11285	7	10995	11525
2	10795	11325	8	11035	11565
3	10835	11365	9	11075	11605
4	10875	11405	10	11115	11645

ver. 1.0

9.3. RAY11 C,D parameters

9.3.1. Output power

RAY11-xC, RAY11-xD Modulation	TX power	
	Max [dBm]	Min [dBm]
QPSK	20	-5
16-QAM	18	-5
32-QAM	17	-5
64-QAM	16	-5
128-QAM	16	-5
256-QAM	15	-5

ver. 2.0

9.3.2. Radio parameters

RAY11-xC, RAY11-xD				Channel spacing 1.75 MHz; ACCP operation				
Modulation	Raw Bit Rate	User Bit Rate	RSS / SNR for BER 10 ⁻⁶		Co-channel rejection		Adjacent channel Selectivity	
					1 dB	3 dB	1 dB	3 dB
			RSS	SNR	declared / limit	declared / limit	declared / limit	declared / limit
[-]	[Mbps]	[dBm]	[dB]	[dB]	[dB]	[dB]	[dB]	
QPSK	3.1	2.5	-98	9.5	15 / 23	12 / 19	-12 / 0	-14 / -4
16-QAM	6.3	4.9	-92	15.0	22 / 30	20 / 26.5	-11 / -3	-13 / -7
32-QAM	7.8	6.3	-88	19.0	24 / 30	22 / 26.5	-10 / -3	-12 / -7
64-QAM	9.4	7.4	-87	20.5	29 / 30	26 / 26.5	-9 / -3	-10 / -7
128-QAM	11.0	8.9	-84	23.5	30 / 30	28 / 26.5	-8 / -3	-7 / -7

ver. 2.0

RAY11-xC, RAY11-xD				Channel spacing 3.5 MHz; ACCP operation				
Modulation	Raw Bit Rate	User Bit Rate	RSS / SNR for BER 10 ⁻⁶		Co-channel rejection		Adjacent channel Selectivity	
					1 dB	3 dB	1 dB	3 dB
			RSS	SNR	declared / limit	declared / limit	declared / limit	declared / limit
[-]	[Mbps]	[dBm]	[dB]	[dB]	[dB]	[dB]	[dB]	
QPSK	6	4.9	-96	9.5	15 / 23	12 / 19	-14 / 0	-16 / -4
16-QAM	12	9.6	-89	15.0	22 / 30	20 / 26.5	-13 / -3	-15 / -7
32-QAM	15	12.1	-86	18.5	24 / 30	22 / 26.5	-12 / -3	-14 / -7
64-QAM	18	14.3	-83	20.5	29 / 30	26 / 26.5	-11 / -3	-12 / -7
128-QAM	21	17.2	-82	23.5	30 / 30	28 / 26.5	-9 / -3	-8 / -7
256-QAM	24	19.7	-80	26.0	33 / 30	31 / 26.5	-5 / -3	-7 / -7

ver. 2.0

RAY11-xC, RAY11-xD				Channel spacing 7 MHz; ACCP operation				
Modulation	Raw Bit Rate	User Bit Rate	RSS / SNR for BER 10 ⁻⁶		Co-channel rejection		Adjacent channel Selectivity	
					1 dB	3 dB	1 dB	3 dB
			RSS	SNR	declared / limit	declared / limit	declared / limit	declared / limit
[-]	[Mbps]	[dBm]	[dB]	[dB]	[dB]	[dB]	[dB]	
QPSK	12	8.5	-94	8.5	15 / 23	12 / 19	-20 / 0	-22 / -4
16-QAM	24	17.2	-87	15.0	22 / 30	20 / 26.5	-18 / -3	-19 / -7
32-QAM	30	22.1	-84	18.5	24 / 37	22 / 33	-16 / -2	-18 / -6
64-QAM	36	29.7	-80	21.5	29 / 37	26 / 33	-14 / -2	-16 / -6
128-QAM	42	34.7	-78	25.0	32 / 37	30 / 33	-12 / -2	-14 / -6
256-QAM	49	40.7	-76	26.0	33 / 37	31 / 33	-10 / -2	-12 / -6

ver. 2.1

RAY11-xC, RAY11-xD					Channel spacing 14 MHz; ACCP operation			
Modulation	Raw Bit Rate	User Bit Rate	RSS / SNR for BER 10 ⁻⁶		Co-channel rejection		Adjacent channel Selectivity	
			RSS	SNR	1 dB	3 dB	1 dB	3 dB
					declared / limit	declared / limit	declared / limit	declared / limit
[-]	[Mbps]	[dBm]	[dB]	[dB]	[dB]	[dB]	[dB]	
QPSK	24	19.9	-92	8.5	14 / 23	12 / 19	-21 / 0	-23 / -4
16-QAM	48	38.8	-85	15.0	20 / 30	18 / 26.5	-19 / -3	-21 / -7
32-QAM	60	49.1	-81	18.5	26 / 33	23 / 29	-17 / -5	-19 / -9
64-QAM	72	62.3	-78	21.5	28 / 37	26 / 33	-14 / -2	-17 / -6
128-QAM	84	73.6	-74	25.0	30 / 37	28 / 33	-12 / -2	-14 / -6
256-QAM	96	81.2	-71	28.0	33 / 37	31 / 33	-10 / -2	-12 / -6

ver. 2.0

RAY11-xC, RAY11-xD					Channel spacing 28 / 30 MHz; ACCP operation			
Modulation	Raw Bit Rate	User Bit Rate	RSS / SNR for BER 10 ⁻⁶		Co-channel rejection		Adjacent channel Selectivity	
			RSS	SNR	1 dB	3 dB	1 dB	3 dB
					declared / limit	declared / limit	declared / limit	declared / limit
[-]	[Mbps]	[dBm]	[dB]	[dB]	[dB]	[dB]	[dB]	
QPSK	50	36.8	-90	7.5	12 / 23	10 / 19	-21 / 0	-23 / -4
16-QAM	100	80.9	-82	15.0	20 / 30	18 / 26.5	-18 / -3	-20 / -7
32-QAM	125	102.4	-78	18.5	24 / 33	22 / 29	-16 / -5	-19 / -9
64-QAM	150	129.8	-75	21.5	28 / 35	26 / 32	-12 / -5	-15 / -8
128QAM	175	155.5	-71	25.0	30 / 35	28 / 32	-9 / -5	-12 / -8
256-QAM	200	170.7	-69	26.5	33 / 35	31 / 32	-6 / -5	-9 / -8

ver. 2.0

RAY11-xC, RAY11-xD					Channel spacing 28 / 30 MHz; ACAP operation			
Modulation	Raw Bit Rate	User Bit Rate	RSS / SNR for BER 10 ⁻⁶		Co-channel rejection		Adjacent channel Selectivity	
			RSS	SNR	1 dB	3 dB	1 dB	3 dB
					declared / limit	declared / limit	declared / limit	declared / limit
[-]	[Mbps]	[dBm]	[dB]	[dB]	[dB]	[dB]	[dB]	
QPSK	52	38.3	-88.5	7.5	12 / 23	10 / 19	-15 / 0	-17 / -4
16-QAM	104	84.1	-81.5	15.0	20 / 30	18 / 26.5	-12 / -3	-14 / -7
32-QAM	130	106.4	-77.5	18.5	24 / 37	22 / 33	-10 / 3	-13 / -1
64-QAM	156	135.0	-74.5	21.5	28 / 37	26 / 33	-6 / 3	-9 / -1
128QAM	182	161.7	-70.5	25.0	30 / 37	28 / 33	-3 / 3	-6 / -1
256-QAM	208	185.2	-68.5	26.5	33 / 41	31 / 38	0 / 10	-3 / 7

ver. 2.1

9.3.3. Nominal frequencies

RAy11 – xC , RAY11 – xD			TX channel nominal frequencies		
Bandwidth: 1.75 MHz			Band 10.5 – 10.68 GHz, duplex spacing 91 MHz		
(Freq.table: rcinfo11_C_91)			(Freq.table: rcinfo11_D_91)		
Ch.No.	Lower [MHz]	Upper [MHz]	Ch.No.	Lower [MHz]	Upper [MHz]
1	10501.375	10592.375	25	10543.375	10634.375
2	10503.125	10594.125	26	10545.125	10636.125
3	10504.875	10595.875	27	10546.875	10637.875
4	10506.625	10597.625	28	10548.625	10639.625
5	10508.375	10599.375	29	10550.375	10641.375
6	10510.125	10601.125	30	10552.125	10643.125
7	10511.875	10602.875	31	10553.875	10644.875
8	10513.625	10604.625	32	10555.625	10646.625
9	10515.375	10606.375	33	10557.375	10648.375
10	10517.125	10608.125	34	10559.125	10650.125
11	10518.875	10609.875	35	10560.875	10651.875
12	10520.625	10611.625	36	10562.625	10653.625
13	10522.375	10613.375	37	10564.375	10655.375
14	10524.125	10615.125	38	10566.125	10657.125
15	10525.875	10616.875	39	10567.875	10658.875
16	10527.625	10618.625	40	10569.625	10660.625
17	10529.375	10620.375	41	10571.375	10662.375
18	10531.125	10622.125	42	10573.125	10664.125
19	10532.875	10623.875	43	10574.875	10665.875
20	10534.625	10625.625	44	10576.625	10667.625
21	10536.375	10627.375	45	10578.375	10669.375
22	10538.125	10629.125	46	10580.125	10671.125
23	10539.875	10630.875	47	10581.875	10672.875
24	10541.625	10632.625	48	10583.625	10674.625

ver. 1.1

RAy11 – xC , RAY11 – xD			TX channel nominal frequencies		
Bandwidth: 3.5 MHz (rec 2)			Band 10.5 – 10.68 GHz, duplex spacing 91 MHz		
ITU-R F.747 rec. 2					
C sub-band (Freq.table: rcinfo11_C_91)			D sub-band (Freq.table: rcinfo11_D_91)		
Ch.No.	Lower [MHz]	Upper [MHz]	Ch.No.	Lower [MHz]	Upper [MHz]
1	10504.0	10595.0	13	10546.0	10637.0
2	10507.5	10598.5	14	10549.5	10640.5
3	10511.0	10602.0	15	10553.0	10644.0
4	10514.5	10605.5	16	10556.5	10647.5
5	10518.0	10609.0	17	10560.0	10651.0
6	10521.5	10612.5	18	10563.5	10654.5
7	10525.0	10616.0	19	10567.0	10658.0
8	10528.5	10619.5	20	10570.5	10661.5
9	10532.0	10623.0	21	10574.0	10665.0
10	10535.5	10626.5	22	10577.5	10668.5
11	10539.0	10630.0	23	10581.0	10672.0

ver. 1.1

RAy11 – xC , RAY11 – xD			TX channel nominal frequencies		
Bandwidth: 3.5 MHz			Band 10.5 – 10.68 GHz, duplex spacing 91 MHz		
			based on 7 MHz		
C sub-band (Freq.table: rcinfo11_C_91)			D sub-band (Freq.table: rcinfo11_D_91)		
Ch.No.	Lower [MHz]	Upper [MHz]	Ch.No.	Lower [MHz]	Upper [MHz]
1	10502.25	10593.25	13	10544.25	10635.25
2	10505.75	10596.75	14	10547.75	10638.75
3	10509.25	10600.25	15	10551.25	10642.25
4	10512.75	10603.75	16	10554.75	10645.75
5	10516.25	10607.25	17	10558.25	10649.25
6	10519.75	10610.75	18	10561.75	10652.75
7	10523.25	10614.25	19	10565.25	10656.25
8	10526.75	10617.75	20	10568.75	10659.75
9	10530.25	10621.25	21	10572.25	10663.25
10	10533.75	10624.75	22	10575.75	10666.75
11	10537.25	10628.25	23	10579.25	10670.25
12	10540.75	10631.75	24	10582.75	10673.75

ver. 1.1

RAy11 – xC , RAY11 – xD			TX channel nominal frequencies		
Bandwidth: 7 MHz			Band 10.5 – 10.68 GHz, duplex spacing 91 MHz		
ITU-R F.747 Annex 1					
C sub-band (Freq.table: rcinfo11_C_91)			D sub-band (Freq.table: rcinfo11_D_91)		
Ch.No.	Lower [MHz]	Upper [MHz]	Ch.No.	Lower [MHz]	Upper [MHz]
1	10504	10595	7	10546	10637
2	10511	10602	8	10553	10644
3	10518	10609	9	10560	10651
4	10525	10616	10	10567	10658
5	10532	10623	11	10574	10665
6	10539	10630	12	10581	10672

ver. 1.2

RAy11 – xC , RAY11 – xD			TX channel nominal frequencies		
Bandwidth: 14 MHz			Band 10.5 – 10.68 GHz, duplex spacing 91 MHz		
based on 7 MHz					
C sub-band (Freq.table: rcinfo11_C_91)			D sub-band (Freq.table: rcinfo11_D_91)		
Ch.No.	Lower [MHz]	Upper [MHz]	Ch.No.	Lower [MHz]	Upper [MHz]
1	10507.5	10598.5	4	10549.5	10640.5
2	10521.5	10612.5	5	10563.5	10654.5
3	10535.5	10626.5	6	10577.5	10668.5

ver. 1.1

RAy11 – xC , RAY11 – xD			TX channel nominal frequencies		
Bandwidth: 28 MHz			Band 10.5 – 10.68 GHz, duplex spacing 91 MHz		
based on 7 MHz					
C sub-band (Freq.table: rcinfo11_C_91)			D sub-band (Freq.table: rcinfo11_D_91)		
Ch.No.	Lower [MHz]	Upper [MHz]	Ch.No.	Lower [MHz]	Upper [MHz]
1	10514.5	10605.5	3	10570.5	10661.5

ver. 1.1

9.4. RAY17 parameters

9.4.1. Output power

RAY17 Modulation	TX power	
	Max [dBm]	Min [dBm]
QPSK	5	-25
16-QAM	5	-25
32-QAM	5	-25
64-QAM	5	-25
128-QAM	5	-25
256-QAM	5	-25

ver. 2.0

9.4.2. Radio parameters

RAY17								Channel spacing 3.5 MHz; ACCP operation			
Modulation	Raw Bit Rate	User Bit Rate	RSS / SNR for BER 10^{-6}		Co-channel rejection		Adjacent channel Selectivity				
			RSS	SNR	1 dB	3 dB	1 dB	3 dB			
					declared / limit	declared / limit	declared / limit	declared / limit			
[-]	[Mbps]	[dBm]	[dB]	[dB]	[dB]	[dB]	[dB]				
QPSK	6	4.9	-96	10.0	15 / 23	12 / 19	-14 / 0	-16 / -4			
16-QAM	12	9.6	-89	15.5	21 / 30	18 / 26.5	-13 / -3	-15 / -7			
32-QAM	15	12.1	-85	20.0	25 / 30	22 / 26.5	-12 / -3	-14 / -7			
64-QAM	18	14.3	-82	23.5	26 / 30	23 / 26.5	-10 / -3	-12 / -7			

ver. 2.0

RAY17								Channel spacing 7 MHz; ACCP operation			
Modulation	Raw Bit Rate	User Bit Rate	RSS / SNR for BER 10^{-6}		Co-channel rejection		Adjacent channel Selectivity				
			RSS	SNR	1 dB	3 dB	1 dB	3 dB			
					declared / limit	declared / limit	declared / limit	declared / limit			
[-]	[Mbps]	[dBm]	[dB]	[dB]	[dB]	[dB]	[dB]				
QPSK	12	8.5	-94	8.5	15 / 23	12 / 19	-20 / 0	-22 / -4			
16-QAM	24	17.2	-87	15.0	22 / 30	20 / 26.5	-18 / -3	-19 / -7			
32-QAM	30	22.1	-84	18.5	24 / 37	22 / 33	-16 / -2	-18 / -6			
64-QAM	36	29.7	-80	21.5	29 / 37	26 / 33	-14 / -2	-16 / -6			
128-QAM	42	34.7	-77	25.0	32 / 37	30 / 33	-12 / -2	-14 / -6			

ver. 2.0

RAY17								Channel spacing 14 MHz; ACCP operation			
Modulation	Raw Bit Rate	User Bit Rate	RSS / SNR for BER 10^{-6}		Co-channel rejection		Adjacent channel Selectivity				
			RSS	SNR	1 dB	3 dB	1 dB	3 dB			
					declared / limit	declared / limit	declared / limit	declared / limit			
[-]	[Mbps]	[dBm]	[dB]	[dB]	[dB]	[dB]	[dB]				
QPSK	24	19.9	-92	8.5	14 / 23	12 / 19	-21 / 0	-23 / -4			
16-QAM	48	38.8	-85	15.0	20 / 30	18 / 26.5	-19 / -3	-21 / -7			
32-QAM	60	49.1	-81	18.5	26 / 33	23 / 29	-17 / -5	-19 / -9			
64-QAM	72	62.3	-78	21.5	28 / 37	26 / 33	-14 / -2	-17 / -6			
128-QAM	84	73.6	-74	25.0	30 / 37	28 / 33	-12 / -2	-14 / -6			
256-QAM	96	81.2	-72	28.0	33 / 37	31 / 33	-10 / -2	-12 / -6			

ver. 2.0

RAY17 Channel spacing 28 MHz; ACCP operation								
Modulation	Raw Bit Rate	User Bit Rate	RSS / SNR for BER 10 ⁻⁶		Co-channel rejection		Adjacent channel Selectivity	
			RSS	SNR	1 dB	3 dB	1 dB	3 dB
					declared / limit	declared / limit	declared / limit	declared / limit
[-]	[Mbps]	[dBm]	[dB]	[dB]	[dB]	[dB]	[dB]	[dB]
QPSK	50	36.8	-90	7.5	12 / 23	10 / 19	-21 / 0	-23 / -4
16-QAM	100	80.9	-83	15.0	20 / 30	18 / 26.5	-18 / -3	-20 / -7
32-QAM	125	102.4	-79	18.5	24 / 33	22 / 29	-16 / -5	-19 / -9
64-QAM	150	129.8	-76	21.5	28 / 35	26 / 32	-12 / -5	-15 / -8
128QAM	175	155.5	-72	25.0	30 / 35	28 / 32	-9 / -5	-12 / -8
256-QAM	200	170.7	-69	26.5	33 / 35	31 / 32	-6 / -5	-9 / -8

ver. 2.0

RAY17 Channel spacing 40 MHz; ACCP operation								
Modulation	Raw Bit Rate	User Bit Rate	RSS / SNR for BER 10 ⁻⁶		Co-channel rejection		Adjacent channel Selectivity	
			RSS	SNR	1 dB	3 dB	1 dB	3 dB
					declared / limit	declared / limit	declared / limit	declared / limit
[-]	[Mbps]	[dBm]	[dB]	[dB]	[dB]	[dB]	[dB]	[dB]
QPSK	68	50.1	-88	7.5	12 / 33	10 / 29	-22 / -4	-24 / -8
16-QAM	136	110.0	-81	15.0	19 / 33	17 / 29	-18 / -4	-21 / -8
32-QAM	170	139.2	-77	18.5	24 / 33	21 / 29	-16 / -4	-19 / -8
64-QAM	204	176.5	-74	21.5	27 / 33	25 / 29	-14 / -4	-16 / -8
128QAM	238	211.4	-70	25.0	30 / 37	28 / 33	-10 / -4	-12 / -8
256-QAM	272	232.1	-68	26.5	33 / 37	30 / 33	-8 / -4	-10 / -8

ver. 2.0

RAY17 Channel spacing 56 MHz; ACCP operation								
Modulation	Raw Bit Rate	User Bit Rate	RSS / SNR for BER 10 ⁻⁶		Co-channel rejection		Adjacent channel Selectivity	
			RSS	SNR	1 dB	3 dB	1 dB	3 dB
					declared / limit	declared / limit	declared / limit	declared / limit
[-]	[Mbps]	[dBm]	[dB]	[dB]	[dB]	[dB]	[dB]	[dB]
QPSK	99	72.9	-87	7.5	12 / 23	10 / 19	-24 / 0	-26 / -4
16-QAM	198	160.2	-80	15.0	19 / 30	17 / 26.5	-18 / -3	-21 / -7
32-QAM	247.5	202.7	-76	18.5	24 / 33	22 / 29	-16 / -5	-19 / -9
64-QAM	297	256.9	-73	21.5	27 / 35	25 / 32	-14 / -5	-16 / -8
128QAM	346.5	303.7	-69	25.0	30 / 35	28 / 32	-10 / -5	-12 / -8
256-QAM	396	337.7	-66	26.5	33 / 35	30 / 32	-8 / -5	-10 / -8

ver. 2.0

RAy17		Channel spacing 56 MHz TO; ACCP operation						
Modulation	Raw Bit Rate	User Bit Rate	RSS / SNR for BER 10^{-6}		Co-channel rejection		Adjacent channel Selectivity	
			RSS	SNR	1 dB	3 dB	1 dB	3 dB
					declared / limit	declared / limit	declared / limit	declared / limit
<i>[-]</i>	<i>[Mbps]</i>	<i>[dBm]</i>	<i>[dB]</i>	<i>[dB]</i>	<i>[dB]</i>	<i>[dB]</i>	<i>[dB]</i>	
QPSK	99	85.8	-85	10.0	13 / 23	11 / 19	-24 / 0	-26 / -4
16-QAM	198	169.9	-78	16.0	20 / 30	18 / 26.5	-18 / -3	-20 / -7
32-QAM	247.5	206.2	-74	19.0	25 / 33	23 / 29	-14 / -5	-15 / -9
64-QAM	297	268.1	-70	22.5	29 / 35	26 / 32	-9 / -5	-11 / -8
128-QAM	346.5	309.0	-67	25.5	32 / 35	29 / 32	-8 / -5	-10 / -8
256-QAM	396	358.9	-64	27.5	35 / 35	32 / 32	-7 / -5	-8 / -8

ver. 2.1

9.4.3. Nominal frequencies

RAy17		TX channel nominal frequencies					
Bandwidth: 3.5 MHz		Band 17.1 – 17.3 GHz, default duplex 73.5 MHz duplex range 60 – 192.5 MHz					
(Freq.table: rcinfo17-default:10)							
basic channels				optional channels			
Ch.No.	Lower [MHz]	Ch.No.	Upper [MHz]	Ch.No.	Lower [MHz]	Ch.No.	Upper [MHz]
		U19	17166.5	no more channels			
		U20	17170.0				
		U21	17173.5				
L1	17103.5	U22	17177.0				
L2	17107.0	U23	17180.5				
L3	17110.5	U24	17184.0				
L4	17114.0	U25	17187.5				
L5	17117.5	U26	17191.0				
L6	17121.0	U27	17194.5				
L7	17124.5	U28	17198.0				
L8	17128.0	U29	17201.5				
L9	17131.5	U30	17205.0				
L10	17135.0	U31	17208.5				
L11	17138.5	U32	17212.0				
L12	17142.0	U33	17215.5				
L13	17145.5	U34	17219.0				
L14	17149.0	U35	17222.5				
L15	17152.5	U36	17226.0				
L16	17156.0	U37	17229.5				
L17	17159.5	U38	17233.0				
L18	17163.0	U39	17236.5				
L19	17166.5	U40	17240.0				
L20	17170.0	U41	17243.5				
L21	17173.5	U42	17247.0				
L22	17177.0	U43	17250.5				
L23	17180.5	U44	17254.0				
L24	17184.0	U45	17257.5				
L25	17187.5	U46	17261.0				
L26	17191.0	U47	17264.5				
L27	17194.5	U48	17268.0				
L28	17198.0	U49	17271.5				
L29	17201.5	U50	17275.0				
L30	17205.0	U51	17278.5				
L31	17208.5	U52	17282.0				
L32	17212.0	U53	17285.5				
L33	17215.5	U54	17289.0				
L34	17219.0	U55	17292.5				
L35	17222.5	U56	17296.0				
L36	17226.0						
L37	17229.5						
L38	17233.0						

ver. 2.1

RAy17		TX channel nominal frequencies					
Bandwidth: 7 MHz		Band 17.1 – 17.3 GHz, default duplex 73.5 MHz duplex range 60 – 192.5 MHz					
(Freq.table: rcinfo17-default:10)							
basic channels				optional channels			
Ch.No.	Lower [MHz]	Ch.No.	Upper [MHz]	Ch.No.	Lower [MHz]	Ch.No.	Upper [MHz]
						U19	17166.5
		U20	17170			U21	17173.5
L1	17103.5	U22	17177				
L3	17110.5	U24	17184	L2	17107	U23	17180.5
L5	17117.5	U26	17191	L4	17114	U25	17187.5
L7	17124.5	U28	17198	L6	17121	U27	17194.5
L9	17131.5	U30	17205	L8	17128	U29	17201.5
L11	17138.5	U32	17212	L10	17135	U31	17208.5
L13	17145.5	U34	17219	L12	17142	U33	17215.5
L15	17152.5	U36	17226	L14	17149	U35	17222.5
L17	17159.5	U38	17233	L16	17156	U37	17229.5
L19	17166.5	U40	17240	L18	17163	U39	17236.5
L21	17173.5	U42	17247	L20	17170	U41	17243.5
L23	17180.5	U44	17254	L22	17177	U43	17250.5
L25	17187.5	U46	17261	L24	17184	U45	17257.5
L27	17194.5	U48	17268	L26	17191	U47	17264.5
L29	17201.5	U50	17275	L28	17198	U49	17271.5
L31	17208.5	U52	17282	L30	17205	U51	17278.5
L33	17215.5	U54	17289	L32	17212	U53	17285.5
L35	17222.5	U56	17296	L34	17219	U55	17292.5
L37	17229.5			L36	17226		
				L38	17233		

ver. 2.1

RAy17		TX channel nominal frequencies					
Bandwidth: 14 MHz		Band 17.1 – 17.3 GHz, default duplex 87.5 MHz					
		duplex range 65 – 185.5 MHz					
(Freq.table: rcinfo17-default:10)							
basic channels				optional channels			
Ch.No.	Lower [MHz]	Ch.No.	Upper [MHz]	Ch.No.	Lower [MHz]	Ch.No.	Upper [MHz]
						U21	17173.5
						U22	17177.0
		U23	17180.5				
						U24	17184.0
						U25	17187.5
						U26	17191.0
L2	17107	U27	17194.5				
				L3	17110.5	U28	17198.0
				L4	17114.0	U29	17201.5
				L5	17117.5	U30	17205.0
L6	17121	U31	17208.5				
				L7	17124.5	U32	17212.0
				L8	17128.0	U33	17215.5
				L9	17131.5	U34	17219.0
L10	17135	U35	17222.5				
				L11	17138.5	U36	17226.0
				L12	17142.0	U37	17229.5
				L13	17145.5	U38	17233.0
L14	17149	U39	17236.5				
				L15	17152.5	U40	17240.0
				L16	17156.0	U41	17243.5
				L17	17159.5	U42	17247.0
L18	17163	U43	17250.5				
				L19	17166.5	U44	17254.0
				L20	17170.0	U45	17257.5
				L21	17173.5	U46	17261.0
L22	17177	U47	17264.5				
				L23	17180.5	U48	17268.0
				L24	17184.0	U49	17271.5
				L25	17187.5	U50	17275.0
L26	17191	U51	17278.5				
				L27	17194.5	U52	17282.0
				L28	17198.0	U53	17285.5
				L29	17201.5	U54	17289.0
L30	17205	U55	17292.5				
				L31	17208.5		
				L32	17212.0		
				L33	17215.5		
L34	17219						
				L35	17222.5		
				L36	17226.0		

ver. 2.1

RAy17		TX channel nominal frequencies					
Bandwidth: 28 MHz		Band 17.1 – 17.3 GHz, default duplex 87.5 MHz					
		duplex range 70 – 171.5 MHz					
(Freq.table: rcinfo17-default:10)							
basic channels				optional channels			
Ch.No.	Lower [MHz]	Ch.No.	Upper [MHz]	Ch.No.	Lower [MHz]	Ch.No.	Upper [MHz]
						U24	17184.0
						U25	17187.5
						U26	17191.0
						U27	17194.5
						U28	17198.0
L4	17114	U29	17201.5				
				L5	17117.5	U30	17205.0
				L6	17121.0	U31	17208.5
				L7	17124.5	U32	17212.0
				L8	17128.0	U33	17215.5
				L9	17131.5	U34	17219.0
				L10	17135.0	U35	17222.5
				L11	17138.5	U36	17226.0
L12	17142	U37	17229.5				
				L13	17145.5	U38	17233.0
				L14	17149.0	U39	17236.5
				L15	17152.5	U40	17240.0
				L16	17156.0	U41	17243.5
				L17	17159.5	U42	17247.0
				L18	17163.0	U43	17250.5
				L19	17166.5	U44	17254.0
L20	17170	U45	17257.5				
				L21	17173.5	U46	17261.0
				L22	17177.0	U47	17264.5
				L23	17180.5	U48	17268.0
				L24	17184.0	U49	17271.5
				L25	17187.5	U50	17275.0
				L26	17191.0	U51	17278.5
				L27	17194.5	U52	17282.0
L28	17198	U53	17285.5				
				L29	17201.5		
				L30	17205.0		
				L31	17208.5		
				L32	17212.0		
				L33	17215.5		

ver. 2.1

RAy17				TX channel nominal frequencies			
Bandwidth: 40 MHz				Band 17.1 – 17.3 GHz, default duplex 73.5 MHz			
				duplex range 70 – 157.5 MHz			
(Freq.table: rcinfo17-default:10)							
basic channels				optional channels			
Ch.No.	Lower [MHz]	Ch.No.	Upper [MHz]	Ch.No.	Lower [MHz]	Ch.No.	Upper [MHz]
L6	17121	U27	17194.5			U26	17191.0
				L7	17124.5	U28	17198.0
				L8	17128.0	U29	17201.5
				L9	17131.5	U30	17205.0
				L10	17135.0	U31	17208.5
				L11	17138.5	U32	17212.0
				L12	17142.0	U33	17215.5
				L13	17145.5	U34	17219.0
				L14	17149.0	U35	17222.5
				L15	17152.5	U36	17226.0
				L16	17156.0	U37	17229.5
				L17	17159.5	U38	17233.0
L18	17163	U39	17236.5	L19	17166.5	U40	17240.0
				L20	17170.0	U41	17243.5
				L21	17173.5	U42	17247.0
				L22	17177.0	U43	17250.5
				L23	17180.5	U44	17254.0
				L24	17184.0	U45	17257.5
				L25	17187.5	U46	17261.0
				L26	17191.0	U47	17264.5
				L27	17194.5	U48	17268.0
				L28	17198.0	U49	17271.5
				L29	17201.5	U50	17275.0
L30	17205	U51	17278.5	L31	17208.5		

ver. 2.1

RAy17		TX channel nominal frequencies					
Bandwidth: 56 MHz		Band 17.1 – 17.3 GHz, default duplex 87.5 MHz duplex range 85 – 143.5 MHz					
(Freq.table: rcinfo17-default:10)							
basic channels				optional channels			
Ch.No.	Lower [MHz]	Ch.No.	Upper [MHz]	Ch.No.	Lower [MHz]	Ch.No.	Upper [MHz]
L8	17128	U33	17215.5	L9	17131.5	U34	17219.0
				L10	17135.0	U35	17222.5
				L11	17138.5	U36	17226.0
				L12	17142.0	U37	17229.5
				L13	17145.5	U38	17233.0
				L14	17149.0	U39	17236.5
				L15	17152.5	U40	17240.0
				L16	17156.0	U41	17243.5
				L17	17159.5	U42	17247.0
				L18	17163.0	U43	17250.5
				L19	17166.5	U44	17254.0
				L20	17170.0	U45	17257.5
				L21	17173.5	U46	17261.0
				L22	17177.0	U47	17264.5
				L23	17180.5	U48	17268.0
L24	17184	U49	17271.5				

ver. 2.1

9.5. RAY24 parameters

9.5.1. Output power

RAY24 Modulation	TX power	
	Max [dBm]	Min [dBm]
QPSK	10	-30
16-QAM	10	-30
32-QAM	10	-30
64-QAM	10	-30
128-QAM	10	-30
256-QAM	10	-30

ver. 1.0

9.5.2. Radio parameters

RAY24		Channel spacing 3.5 MHz; ACCP operation						
Modulation	Raw Bit Rate	User Bit Rate	RSS / SNR for BER 10 ⁻⁶		Co-channel rejection		Adjacent channel Selectivity	
			RSS	SNR	1 dB	3 dB	1 dB	3 dB
					declared / limit	declared / limit	declared / limit	declared / limit
[-]	[Mbps]	[dBm]	[dB]	[dB]	[dB]	[dB]	[dB]	
QPSK	6	4.9	-96	9.5	15 / 23	12 / 19	-14 / 0	-16 / -4
16-QAM	12	9.6	-89	15.0	22 / 30	20 / 26.5	-13 / -3	-15 / -7
32-QAM	15	12.1	-86	18.5	24 / 30	22 / 26.5	-12 / -3	-14 / -7
64-QAM	18	14.3	-83	20.5	29 / 30	26 / 26.5	-11 / -3	-12 / -7
128-QAM	21	17.2	-79	23.5	30 / 30	28 / 26.5	-9 / -3	-8 / -7
256-QAM	24	19.7	-77	26.0	33 / 30	31 / 26.5	-5 / -3	-7 / -7

ver. 1.0

RAY24		Channel spacing 7 MHz; ACCP operation						
Modulation	Raw Bit Rate	User Bit Rate	RSS / SNR for BER 10 ⁻⁶		Co-channel rejection		Adjacent channel Selectivity	
			RSS	SNR	1 dB	3 dB	1 dB	3 dB
					declared / limit	declared / limit	declared / limit	declared / limit
[-]	[Mbps]	[dBm]	[dB]	[dB]	[dB]	[dB]	[dB]	
QPSK	12	8.5	-93	8.5	15 / 23	12 / 19	-20 / 0	-22 / -4
16-QAM	24	17.2	-86	15.0	22 / 30	20 / 26.5	-18 / -3	-19 / -7
32-QAM	30	22.1	-83	18.5	24 / 37	22 / 33	-16 / -2	-18 / -6
64-QAM	36	29.7	-79	21.5	29 / 37	26 / 33	-14 / -2	-16 / -6
128-QAM	42	34.7	-76	25.0	32 / 37	30 / 33	-12 / -2	-14 / -6
256-QAM	49	40.7	-74	26.0	33 / 37	31 / 33	-10 / -2	-12 / -6

ver. 1.0

RAY24 Channel spacing 14 MHz; ACCP operation								
Modulation	Raw Bit Rate	User Bit Rate	RSS / SNR for BER 10 ⁻⁶		Co-channel rejection		Adjacent channel Selectivity	
			RSS	SNR	1 dB	3 dB	1 dB	3 dB
					declared / limit	declared / limit	declared / limit	declared / limit
[-]	[Mbps]	[dBm]	[dB]	[dB]	[dB]	[dB]	[dB]	[dB]
QPSK	24	19.9	-91	8.5	14 / 23	12 / 19	-21 / 0	-23 / -4
16-QAM	48	38.8	-84	15.0	20 / 30	18 / 26.5	-19 / -3	-21 / -7
32-QAM	60	49.1	-80	18.5	26 / 33	23 / 29	-17 / -5	-19 / -9
64-QAM	72	62.3	-77	21.5	28 / 37	26 / 33	-14 / -2	-17 / -6
128-QAM	84	73.6	-73	25.0	30 / 37	28 / 33	-12 / -2	-14 / -6
256-QAM	96	81.2	-71	28.0	33 / 37	31 / 33	-10 / -2	-12 / -6

ver. 1.0

RAY24 Channel spacing 28 MHz; ACCP operation								
Modulation	Raw Bit Rate	User Bit Rate	RSS / SNR for BER 10 ⁻⁶		Co-channel rejection		Adjacent channel Selectivity	
			RSS	SNR	1 dB	3 dB	1 dB	3 dB
					declared / limit	declared / limit	declared / limit	declared / limit
[-]	[Mbps]	[dBm]	[dB]	[dB]	[dB]	[dB]	[dB]	[dB]
QPSK	50	36.8	-89	7.5	12 / 23	10 / 19	-21 / 0	-23 / -4
16-QAM	100	80.9	-82	15.0	20 / 30	18 / 26.5	-18 / -3	-20 / -7
32-QAM	125	102.4	-78	18.5	24 / 33	22 / 29	-16 / -5	-19 / -9
64-QAM	150	129.8	-75	21.5	28 / 35	26 / 32	-12 / -5	-15 / -8
128-QAM	175	155.5	-71	25.0	30 / 35	28 / 32	-9 / -5	-12 / -8
256-QAM	200	170.7	-68	26.5	33 / 35	31 / 32	-6 / -5	-9 / -8

ver. 1.0

RAY24 Channel spacing 40 MHz; ACCP operation								
Modulation	Raw Bit Rate	User Bit Rate	RSS / SNR for BER 10 ⁻⁶		Co-channel rejection		Adjacent channel Selectivity	
			RSS	SNR	1 dB	3 dB	1 dB	3 dB
					declared / limit	declared / limit	declared / limit	declared / limit
[-]	[Mbps]	[dBm]	[dB]	[dB]	[dB]	[dB]	[dB]	[dB]
QPSK	68	50.1	-87	7.5	12 / 33	10 / 29	-22 / -4	-24 / -8
16-QAM	136	110.0	-80	15.0	19 / 33	17 / 29	-18 / -4	-21 / -8
32-QAM	170	139.2	-76	18.5	24 / 33	21 / 29	-16 / -4	-19 / -8
64-QAM	204	176.5	-75	21.5	27 / 33	25 / 29	-14 / -4	-16 / -8
128-QAM	238	211.4	-69	25.0	30 / 37	28 / 33	-10 / -4	-12 / -8
256-QAM	272	232.1	-67	26.5	33 / 37	30 / 33	-8 / -4	-10 / -8

ver. 1.0

RAY24 Channel spacing 56 MHz; ACCP operation								
Modulation	Raw Bit Rate	User Bit Rate	RSS / SNR for BER 10^{-6}		Co-channel rejection		Adjacent channel Selectivity	
					1 dB	3 dB	1 dB	3 dB
			RSS	SNR	declared / limit	declared / limit	declared / limit	declared / limit
[-]	[Mbps]	[dBm]	[dB]	[dB]	[dB]	[dB]	[dB]	[dB]
QPSK	99	72.9	-86	7.5	12 / 23	10 / 19	-26 / 0	-28 / -4
16-QAM	198	160.2	-79	15.0	19 / 30	17 / 26.5	-19 / -3	-21 / -7
32-QAM	247.5	202.7	-75	18.5	24 / 33	22 / 29	-15 / -5	-17 / -9
64-QAM	297	256.9	-72	21.5	27 / 35	25 / 32	-14 / -5	-16 / -8
128-QAM	346.5	303.7	-68	25.0	30 / 35	28 / 32	-10 / -5	-12 / -8
256-QAM	396	337.7	-65	26.5	33 / 35	30 / 32	-8 / -5	-10 / -8

ver. 1.0

RAY24 Channel spacing 56 MHz TO; ACCP operation								
Modulation	Raw Bit Rate	User Bit Rate	RSS / SNR for BER 10^{-6}		Co-channel rejection		Adjacent channel Selectivity	
					1 dB	3 dB	1 dB	3 dB
			RSS	SNR	declared / limit	declared / limit	declared / limit	declared / limit
[-]	[Mbps]	[dBm]	[dB]	[dB]	[dB]	[dB]	[dB]	[dB]
QPSK	99	85.8	-84	10.0	13 / 23	11 / 19	-24 / 0	-26 / -4
16-QAM	198	169.9	-77	16.0	20 / 30	18 / 26.5	-18 / -3	-20 / -7
32-QAM	247.5	206.2	-73	19.0	25 / 33	23 / 29	-14 / -5	-15 / -9
64-QAM	297	268.1	-69	22.5	29 / 35	26 / 32	-9 / -5	-11 / -8
128-QAM	346.5	309.0	-66	25.5	32 / 35	29 / 32	-8 / -5	-10 / -8
256-QAM	396	358.9	-63	27.5	35 / 35	32 / 32	-7 / -5	-8 / -8

ver. 1.1

9.5.3. Nominal frequencies - ISM

RAy24		TX channel nominal frequencies			
Bandwidth: 3.5 MHz		Band 24.0 – 24.25 GHz, default duplex sp. 73.5 MHz			
		duplex spacing range 60 – 241.5 MHz			
(Freq.table: rcinfo24_ISM)					
basic channels (default duplex)				optional channels	
Ch.No.	Lower [MHz]	Ch.No.	Upper [MHz]	Ch.No.	Upper [MHz]
		U19	24067.5	no more channels	
		U20	24071.0		
		U21	24074.5		
L1	24004.5	U22	24078.0		
L2	24008.0	U23	24081.5		
L3	24011.5	U24	24085.0		
L4	24015.0	U25	24088.5		
L5	24018.5	U26	24092.0		
L6	24022.0	U27	24095.5		
L7	24025.5	U28	24099.0		
L8	24029.0	U29	24102.5		
L9	24032.5	U30	24106.0		
L10	24036.0	U31	24109.5		
L11	24039.5	U32	24113.0		
L12	24043.0	U33	24116.5		
L13	24046.5	U34	24120.0		
L14	24050.0	U35	24123.5		
L15	24053.5	U36	24127.0		
L16	24057.0	U37	24130.5		
L17	24060.5	U38	24134.0		
L18	24064.0	U39	24137.5		
L19	24067.5	U40	24141.0		
L20	24071.0	U41	24144.5		
L21	24074.5	U42	24148.0		
L22	24078.0	U43	24151.5		
L23	24081.5	U44	24155.0		
L24	24085.0	U45	24158.5		
L25	24088.5	U46	24162.0		
L26	24092.0	U47	24165.5		
L27	24095.5	U48	24169.0		
L28	24099.0	U49	24172.5		
L29	24102.5	U50	24176.0		
L30	24106.0	U51	24179.5		
L31	24109.5	U52	24183.0		
L32	24113.0	U53	24186.5		
L33	24116.5	U54	24190.0		
L34	24120.0	U55	24193.5		
L35	24123.5	U56	24197.0		
L36	24127.0	U57	24200.5		
L37	24130.5	U58	24204.0		
L38	24134.0	U59	24207.5		
L39	24137.5	U60	24211.0		
L40	24141.0	U61	24214.5		
L41	24144.5	U62	24218.0		
L42	24148.0	U63	24221.5		
L43	24151.5	U64	24225.0		
L44	24155.0	U65	24228.5		
L45	24158.5	U66	24232.0		
L46	24162.0	U67	24235.5		
L47	24165.5	U68	24239.0		
L48	24169.0	U69	24242.5		
L49	24172.5	U70	24246.0		
L50	24176.0				
L51	24179.5				
L52	24183.0				

ver. 1.0

RAY24		TX channel nominal frequencies			
Bandwidth: 7 MHz		Band 24.0 – 24.25 GHz, default duplex sp. 73.5 MHz			
		duplex spacing range 60 – 241.5 MHz			
(Freq.table: rcinfo24_ISM)					
basic channels (default duplex)				optional channels	
Ch.No.	Lower [MHz]	Ch.No.	Upper [MHz]	Ch.No.	Upper [MHz]
		U20	24071.0	U19	24067.5
L1	24004.5	U22	24078.0	U21	24074.5
L3	24011.5	U24	24085.0	L2	24008.0
L5	24018.5	U26	24092.0	L4	24015.0
L7	24025.5	U28	24099.0	L6	24022.0
L9	24032.5	U30	24106.0	L8	24029.0
L11	24039.5	U32	24113.0	L10	24036.0
L13	24046.5	U34	24120.0	L12	24043.0
L15	24053.5	U36	24127.0	L14	24050.0
L17	24060.5	U38	24134.0	L16	24057.0
L19	24067.5	U40	24141.0	L18	24064.0
L21	24074.5	U42	24148.0	L20	24071.0
L23	24081.5	U44	24155.0	L22	24078.0
L25	24088.5	U46	24162.0	L24	24085.0
L27	24095.5	U48	24169.0	L26	24092.0
L29	24102.5	U50	24176.0	L28	24099.0
L31	24109.5	U52	24183.0	L30	24106.0
L33	24116.5	U54	24190.0	L32	24113.0
L35	24123.5	U56	24197.0	L34	24120.0
L37	24130.5	U58	24204.0	L36	24127.0
L39	24137.5	U60	24211.0	L38	24134.0
L41	24144.5	U62	24218.0	L40	24141.0
L43	24151.5	U64	24225.0	L42	24148.0
L45	24158.5	U66	24232.0	L44	24155.0
L47	24165.5	U68	24239.0	L46	24162.0
L49	24172.5	U70	24246.0	L48	24169.0
L51	24179.5			L50	24176.0
				L52	24183.0

ver. 1.0

RAy24		TX channel nominal frequencies			
Bandwidth: 14 MHz		Band 24.0 – 24.25 GHz, default duplex sp. 87.5 MHz			
		duplex spacing range 65 – 234.5 MHz			
(Freq.table: rcinfo24_ISM)					
basic channels (default duplex)				optional channels	
Ch.No.	Lower [MHz]	Ch.No.	Upper [MHz]	Ch.No.	Upper [MHz]
				U21	24074.5
				U22	24078.0
		U23	24081.5		
				U24	24085.0
				U25	24088.5
				U26	24092.0
L2	24008	U27	24095.5		
				L3	24011.5
				L4	24015.0
				L5	24018.5
				U28	24099.0
				U29	24102.5
				U30	24106.0
L6	24022	U31	24109.5		
				L7	24025.5
				L8	24029.0
				L9	24032.5
				U32	24113.0
				U33	24116.5
				U34	24120.0
L10	24036	U35	24123.5		
				L11	24039.5
				L12	24043.0
				L13	24046.5
				U36	24127.0
				U37	24130.5
				U38	24134.0
L14	24050	U39	24137.5		
				L15	24053.5
				L16	24057.0
				L17	24060.5
				U40	24141.0
				U41	24144.5
				U42	24148.0
L18	24064	U43	24151.5		
				L19	24067.5
				L20	24071.0
				L21	24074.5
				U44	24155.0
				U45	24158.5
				U46	24162.0
L22	24078	U47	24165.5		
				L23	24081.5
				L24	24085.0
				L25	24088.5
				U48	24169.0
				U49	24172.5
				U50	24176.0
L26	24092	U51	24179.5		
				L27	24095.5
				L28	24099.0
				L29	24102.5
				U52	24183.0
				U53	24186.5
				U54	24190.0
L30	24106	U55	24193.5		
				L31	24109.5
				L32	24113.0
				L33	24116.5
				U56	24197.0
				U57	24200.5
				U58	24204.0
L34	24120	U59	24207.5		
				L35	24123.5
				L36	24127.0
				L37	24130.5
				U60	24211.0
				U61	24214.5
				U62	24218.0
L38	24134	U63	24221.5		
				L39	24137.5
				L40	24141.0
				L41	24144.5
				U64	24225.0
				U65	24228.5
				U66	24232.0
L42	24148	U67	24235.5		
				L43	24151.5
				L44	24155.0
				L45	24158.5
				U68	24239.0
				U69	24242.5
L46	24162				
				L47	24165.5
				L48	24169.0
				L49	24172.5
				L50	24176.0

ver. 1.0

RAy24				TX channel nominal frequencies			
				Band 24.0 – 24.25 GHz, default duplex sp. 87.5 MHz			
Bandwidth: 28 MHz				duplex spacing range 70 – 220.5 MHz			
(Freq.table: rcinfo24_ISM)							
basic channels (default duplex)				optional channels			
Ch.No.	Lower [MHz]	Ch.No.	Upper [MHz]	Ch.No.	Lower [MHz]	Ch.No.	Upper [MHz]
						U24	24085.0
						U25	24088.5
						U26	24092.0
						U27	24095.5
						U28	24099.0
L4	24015	U29	24102.5				
				L5	24018.5	U30	24106.0
				L6	24022.0	U31	24109.5
				L7	24025.5	U32	24113.0
				L8	24029.0	U33	24116.5
				L9	24032.5	U34	24120.0
				L10	24036.0	U35	24123.5
				L11	24039.5	U36	24127.0
L12	24043	U37	24130.5				
				L13	24046.5	U38	24134.0
				L14	24050.0	U39	24137.5
				L15	24053.5	U40	24141.0
				L16	24057.0	U41	24144.5
				L17	24060.5	U42	24148.0
				L18	24064.0	U43	24151.5
				L19	24067.5	U44	24155.0
L20	24071	U45	24158.5				
				L21	24074.5	U46	24162.0
				L22	24078.0	U47	24165.5
				L23	24081.5	U48	24169.0
				L24	24085.0	U49	24172.5
				L25	24088.5	U50	24176.0
				L26	24092.0	U51	24179.5
				L27	24095.5	U52	24183.0
L28	24099	U53	24186.5				
				L29	24102.5	U54	24190.0
				L30	24106.0	U55	24193.5
				L31	24109.5	U56	24197.0
				L32	24113.0	U57	24200.5
				L33	24116.5	U58	24204.0
				L34	24120.0	U59	24207.5
				L35	24123.5	U60	24211.0
L36	24127	U61	24214.5				
				L37	24130.5	U62	24218.0
				L38	24134.0	U63	24221.5
				L39	24137.5	U64	24225.0
				L40	24141.0	U65	24228.5
				L41	24144.5	U66	24232.0
				L42	24148.0	U67	24235.5
				L43	24151.5		
L44	24155			L45	24158.5		
				L46	24162.0		
				L47	24165.5		

ver. 1.0

RAy24		TX channel nominal frequencies					
		Band 24.0 – 24.25 GHz, default duplex sp. 73.5 MHz					
Bandwidth: 40 MHz		duplex spacing range 70 – 206.5 MHz					
(Freq.table: rcinfo24_ISM)							
basic channels (default duplex)				optional channels			
Ch.No.	Lower [MHz]	Ch.No.	Upper [MHz]	Ch.No.	Lower [MHz]	Ch.No.	Upper [MHz]
L6	24022.0	U27	24095.5			U26	24092.0
				L7	24025.5	U28	24099.0
				L8	24029.0	U29	24102.5
				L9	24032.5	U30	24106.0
				L10	24036.0	U31	24109.5
				L11	24039.5	U32	24113.0
				L12	24043.0	U33	24116.5
				L13	24046.5	U34	24120.0
				L14	24050.0	U35	24123.5
				L15	24053.5	U36	24127.0
				L16	24057.0	U37	24130.5
				L17	24060.5	U38	24134.0
L18	24064.0	U39	24137.5	L19	24067.5	U40	24141.0
				L20	24071.0	U41	24144.5
				L21	24074.5	U42	24148.0
				L22	24078.0	U43	24151.5
				L23	24081.5	U44	24155.0
				L24	24085.0	U45	24158.5
				L25	24088.5	U46	24162.0
				L26	24092.0	U47	24165.5
				L27	24095.5	U48	24169.0
				L28	24099.0	U49	24172.5
				L29	24102.5	U50	24176.0
L30	24106.0	U51	24179.5	L31	24109.5	U52	24183.0
				L32	24113.0	U53	24186.5
				L33	24116.5	U54	24190.0
				L34	24120.0	U55	24193.5
				L35	24123.5	U56	24197.0
				L36	24127.0	U57	24200.5
				L37	24130.5	U58	24204.0
				L38	24134.0	U59	24207.5
				L39	24137.5	U60	24211.0
				L40	24141.0	U61	24214.5
				L41	24144.5	U62	24218.0
L42	24148.0	U63	24221.5	L43	24151.5	U64	24225.0
				L44	24155.0	U65	24228.5
				L45	24158.5		

ver. 1.0

RAy24		TX channel nominal frequencies			
Bandwidth: 56 MHz		Band 24.0 – 24.25 GHz, default duplex sp. 87.5 MHz			
		duplex spacing range 85 – 192.5 MHz			
(Freq.table: rcinfo24_ISM)					
basic channels (default duplex)				optional channels	
Ch.No.	Lower [MHz]	Ch.No.	Upper [MHz]	Ch.No.	Upper [MHz]
L8	24029	U33	24116.5	L9	24032.5
				L10	24036.0
				L11	24039.5
				L12	24043.0
				L13	24046.5
				L14	24050.0
				L15	24053.5
				L16	24057.0
				L17	24060.5
				L18	24064.0
				L19	24067.5
				L20	24071.0
				L21	24074.5
				L22	24078.0
				L23	24081.5
				L25	24088.5
				L26	24092.0
				L27	24095.5
				L28	24099.0
				L29	24102.5
				L30	24106.0
				L31	24109.5
				L32	24113.0
				L33	24116.5
				L34	24120.0
				L35	24123.5
				L36	24127.0
				L37	24130.5
				L38	24134.0
L24	24085	U49	24172.5	U34	24120.0
				U35	24123.5
				U36	24127.0
				U37	24130.5
				U38	24134.0
				U39	24137.5
				U40	24141.0
				U41	24144.5
				U42	24148.0
				U43	24151.5
				U44	24155.0
				U45	24158.5
				U46	24162.0
				U47	24165.5
				U48	24169.0
				U50	24176.0
				U51	24179.5
				U52	24183.0
				U53	24186.5
				U54	24190.0
				U55	24193.5
				U56	24197.0
				U57	24200.5
				U58	24204.0
				U59	24207.5
				U60	24211.0
				U61	24214.5
				U62	24218.0
				U63	24221.5

ver. 1.0

9.5.4. Nominal frequencies - FCC ETSI

RAy24		TX channel nominal frequencies			
Bandwidth: 3.5 MHz		Band 24.05 – 24.25 GHz, default duplex sp. 73.5 MHz			
		duplex spacing range 60 – 192.5 MHz			
(Freq.table: rcinfo24_FCC_ETSI)					
basic channels (default duplex)				optional channels	
Ch.No.	Lower [MHz]	Ch.No.	Upper [MHz]	Ch.No.	Lower [MHz]
		U19	24116.5	no more channels	
		U20	24120.0		
		U21	24123.5		
L1	24053.5	U22	24127.0		
L2	24057.0	U23	24130.5		
L3	24060.5	U24	24134.0		
L4	24064.0	U25	24137.5		
L5	24067.5	U26	24141.0		
L6	24071.0	U27	24144.5		
L7	24074.5	U28	24148.0		
L8	24078.0	U29	24151.5		
L9	24081.5	U30	24155.0		
L10	24085.0	U31	24158.5		
L11	24088.5	U32	24162.0		
L12	24092.0	U33	24165.5		
L13	24095.5	U34	24169.0		
L14	24099.0	U35	24172.5		
L15	24102.5	U36	24176.0		
L16	24106.0	U37	24179.5		
L17	24109.5	U38	24183.0		
L18	24113.0	U39	24186.5		
L19	24116.5	U40	24190.0		
L20	24120.0	U41	24193.5		
L21	24123.5	U42	24197.0		
L22	24127.0	U43	24200.5		
L23	24130.5	U44	24204.0		
L24	24134.0	U45	24207.5		
L25	24137.5	U46	24211.0		
L26	24141.0	U47	24214.5		
L27	24144.5	U48	24218.0		
L28	24148.0	U49	24221.5		
L29	24151.5	U50	24225.0		
L30	24155.0	U51	24228.5		
L31	24158.5	U52	24232.0		
L32	24162.0	U53	24235.5		
L33	24165.5	U54	24239.0		
L34	24169.0	U55	24242.5		
L35	24172.5	U56	24246.0		
L36	24176.0				
L37	24179.5				
L38	24183.0				

ver. 1.0

RAy24		TX channel nominal frequencies					
Bandwidth: 7 MHz		Band 24.05 – 24.25 GHz, default duplex sp. 73.5 MHz					
		duplex spacing range 60 – 192.5 MHz					
(Freq.table: rcinfo24_FCC_ETSI)							
basic channels (default duplex)				optional channels			
Ch.No.	Lower [MHz]	Ch.No.	Upper [MHz]	Ch.No.	Lower [MHz]	Ch.No.	Upper [MHz]
		U20	24071.0			U19	24116.5
						U21	24123.5
L1	24053.5	U22	24127.0				
L3	24060.5	U24	24134.0	L2	24057.0	U23	24130.5
L5	24067.5	U26	24141.0	L4	24064.0	U25	24137.5
L7	24074.5	U28	24148.0	L6	24071.0	U27	24144.5
L9	24081.5	U30	24155.0	L8	24078.0	U29	24151.5
L11	24088.5	U32	24162.0	L10	24085.0	U31	24158.5
L13	24095.5	U34	24169.0	L12	24092.0	U33	24165.5
L15	24102.5	U36	24176.0	L14	24099.0	U35	24172.5
L17	24109.5	U38	24183.0	L16	24106.0	U37	24179.5
L19	24116.5	U40	24190.0	L18	24113.0	U39	24186.5
L21	24123.5	U42	24197.0	L20	24120.0	U41	24193.5
L23	24130.5	U44	24204.0	L22	24127.0	U43	24200.5
L25	24137.5	U46	24211.0	L24	24134.0	U45	24207.5
L27	24144.5	U48	24218.0	L26	24141.0	U47	24214.5
L29	24151.5	U50	24225.0	L28	24148.0	U49	24221.5
L31	24158.5	U52	24232.0	L30	24155.0	U51	24228.5
L33	24165.5	U54	24239.0	L32	24162.0	U53	24235.5
L35	24172.5	U56	24246.0	L34	24169.0	U55	24242.5
L37	24179.5			L36	24176.0		
				L38	24183.0		

ver. 1.0

RAy24		TX channel nominal frequencies			
Bandwidth: 14 MHz		Band 24.05 – 24.25 GHz, default duplex sp. 87.5 MHz			
		duplex spacing range 65 – 185.5 MHz			
(Freq.table: rcinfo24_FCC_ETSI)					
basic channels (default duplex)				optional channels	
Ch.No.	Lower [MHz]	Ch.No.	Upper [MHz]	Ch.No.	Upper [MHz]
				U21	24123.5
				U22	24127.0
		U23	24130.5		
				U24	24134.0
				U25	24137.5
				U26	24141.0
L2	24057	U27	24144.5		
				L3	24060.5
				L4	24064.0
				L5	24067.5
				U28	24148.0
				U29	24151.5
L6	24071	U31	24158.5	U30	24155.0
				L7	24074.5
				U32	24162.0
				L8	24078.0
				U33	24165.5
				L9	24081.5
				U34	24169.0
L10	24085	U35	24172.5		
				L11	24088.5
				U36	24176.0
				L12	24092.0
				U37	24179.5
				L13	24095.5
				U38	24183.0
L14	24099	U39	24186.5		
				L15	24102.5
				U40	24190.0
				L16	24106.0
				U41	24193.5
				L17	24109.5
				U42	24197.0
L18	24113	U43	24200.5		
				L19	24116.5
				U44	24204.0
				L20	24120.0
				U45	24207.5
				L21	24123.5
				U46	24211.0
L22	24127	U47	24214.5		
				L23	24130.5
				U48	24218.0
				L24	24134.0
				U49	24221.5
				L25	24137.5
				U50	24225.0
L26	24141	U51	24228.5		
				L27	24144.5
				U52	24232.0
				L28	24148.0
				U53	24235.5
				L29	24151.5
				U54	24239.0
L30	24155	U55	24242.5		
				L31	24158.5
				L32	24162.0
				L33	24165.5
L34	24169				
				L35	24172.5
				L36	24176.0

ver. 1.0

RAy24		TX channel nominal frequencies					
Bandwidth: 28 MHz		Band 24.05 – 24.25 GHz, default duplex sp. 87.5 MHz					
		duplex spacing range 70 – 171.5 MHz					
(Freq.table: rcinfo24_FCC_ETSI)							
basic channels (default duplex)				optional channels			
Ch.No.	Lower [MHz]	Ch.No.	Upper [MHz]	Ch.No.	Lower [MHz]	Ch.No.	Upper [MHz]
						U25	24137.5
						U26	24141.0
						U27	24144.5
						U28	24148.0
L4	24064	U29	24151.5				
				L5	24067.5	U30	24155.0
				L6	24071.0	U31	24158.5
				L7	24074.5	U32	24162.0
				L8	24078.0	U33	24165.5
				L9	24081.5	U34	24169.0
				L10	24085.0	U35	24172.5
				L11	24088.5	U36	24176.0
L12	24092	U37	24179.5				
				L13	24095.5	U38	24183.0
				L14	24099.0	U39	24186.5
				L15	24102.5	U40	24190.0
				L16	24106.0	U41	24193.5
				L17	24109.5	U42	24197.0
				L18	24113.0	U43	24200.5
				L19	24116.5	U44	24204.0
L20	24120	U45	24207.5				
				L21	24123.5	U46	24211.0
				L22	24127.0	U47	24214.5
				L23	24130.5	U48	24218.0
				L24	24134.0	U49	24221.5
				L25	24137.5	U50	24225.0
				L26	24141.0	U51	24228.5
				L27	24144.5	U52	24232.0
L28	24148	U53	24235.5				
				L29	24151.5		
				L30	24155.0		
				L31	24158.5		
				L32	24162.0		

ver. 1.0

RAy24		TX channel nominal frequencies					
Bandwidth: 40 MHz		Band 24.05 – 24.25 GHz, default duplex sp. 73.5 MHz					
		duplex spacing range 70 – 157.5 MHz					
(Freq.table: rcinfo24_FCC_ETSI)							
basic channels (default duplex)				optional channels			
Ch.No.	Lower [MHz]	Ch.No.	Upper [MHz]	Ch.No.	Lower [MHz]	Ch.No.	Upper [MHz]
L6	24071.0	U27	24144.5			U26	24141.0
				L7	24074.5	U28	24148.0
				L8	24078.0	U29	24151.5
				L9	24081.5	U30	24155.0
				L10	24085.0	U31	24158.5
				L11	24088.5	U32	24162.0
				L12	24092.0	U33	24165.5
				L13	24095.5	U34	24169.0
				L14	24099.0	U35	24172.5
				L15	24102.5	U36	24176.0
				L16	24106.0	U37	24179.5
				L17	24109.5	U38	24183.0
L18	24113.0	U39	24186.5	L19	24116.5	U40	24190.0
				L20	24120.0	U41	24193.5
				L21	24123.5	U42	24197.0
				L22	24127.0	U43	24200.5
				L23	24130.5	U44	24204.0
				L24	24134.0	U45	24207.5
				L25	24137.5	U46	24211.0
				L26	24141.0	U47	24214.5
				L27	24144.5	U48	24218.0
				L28	24148.0	U49	24221.5
				L29	24151.5	U50	24225.0
L30	24155.0	U51	24228.5	L31	24158.5		

ver. 1.0

RAy24		TX channel nominal frequencies			
Bandwidth: 56 MHz		Band 24.05 – 24.25 GHz, default duplex sp. 87.5 MHz			
		duplex spacing range 85 – 143.5 MHz			
(Freq.table: rcinfo24_FCC_ETSI)					
basic channels (default duplex)				optional channels	
Ch.No.	Lower [MHz]	Ch.No.	Upper [MHz]	Ch.No.	Upper [MHz]
L8	24078	U33	24165.5	L9	24081.5
				L10	24085.0
				L11	24088.5
				L12	24092.0
				L13	24095.5
				L14	24099.0
				L15	24102.5
				L16	24106.0
				L17	24109.5
				L18	24113.0
				L19	24116.5
				L20	24120.0
				L21	24123.5
				L22	24127.0
				L23	24130.5
L24	24134	U49	24221.5	U34	24169.0
				U35	24172.5
				U36	24176.0
				U37	24179.5
				U38	24183.0
				U39	24186.5
				U40	24190.0
				U41	24193.5
				U42	24197.0
				U43	24200.5
				U44	24204.0
				U45	24207.5
				U46	24211.0
				U47	24214.5
				U48	24218.0

ver. 1.0

10. Safety, environment, licensing

10.1. Frequency

RAY microwave links designed for operation in licensed bands must be used in accordance with license issued by the Telecommunications Authority for the area the device is operating in.

RAY microwave links designed for operation in ISM bands must comply with the maximum permitted radiated power (EIRP) in accordance with conditions of the given country.

10.2. RoHS and WEEE compliance

RoHS
compliant

WEEE
compliant

This product is fully compliant with the European Parliament's 2011/65/EU RoHS (Restriction of Certain Hazardous Substances in Electrical and Electronic Equipment) and 2012/19/EU WEEE (Waste Electrical and Electronic Equipment) environmental directives.



Used equipment must be collected separately, and disposed of properly. Racom has instigated a programme to manage the reuse, recycling, and recovery of waste in an environmentally safe manner using processes that comply with the WEEE Directive.

Battery Disposal - This product may contain a battery. Batteries must be disposed of properly, and may not be disposed of as unsorted municipal waste within the European Union. See the product documentation for specific battery information. Batteries are marked with a symbol, which may include lettering to indicate cadmium (Cd), lead (Pb), or mercury (Hg). For proper recycling, return the battery to your supplier or to a designated collection point.

10.3. Conditions of Liability for Defects and Instructions for Safe Operation of Equipment

Please read these safety instructions carefully before using the product:

- Liability for defects does not apply to any product that has been used in a manner which conflicts with the instructions contained in this operator manual, or if the case in which the radio modem is located has been opened, or if the equipment has been tampered with.
- The radio equipment can only be operated on frequencies stipulated by the body authorised by the radio operation administration in the respective country and cannot exceed the maximum permitted output power. RACOM is not responsible for products used in an unauthorised way.
- Equipment mentioned in this operator manual may only be used in accordance with instructions contained in this manual. Error-free and safe operation of this equipment is only guaranteed if this equipment is transported, stored, operated and controlled in the proper manner. The same applies to equipment maintenance.

- In order to prevent damage to the radio modem and other terminal equipment the supply must always be disconnected upon connecting or disconnecting the cable to the radio modem data interface. It is necessary to ensure that connected equipment has been grounded to the same potential.
- Only undermentioned manufacturer is entitled to repair any devices.
- Should the RAY unit be used with accessories other than those recommended, Racom takes no responsibility for any malfunction caused by the use of such accessories. Using unsuitable accessories (e.g.cable connectors) can result in a mechanical damage to RAY internal connectors, allow the penetration of water inside the unit, or reduce the efficiency of internal surge protection circuits.

10.4. Important Notifications

Sole owner of all rights to this operating manual is the company RACOM s. r. o. (further in this manual referred to under the abbreviated name RACOM). All rights reserved. Drawing written, printed or reproduced copies of this manual or records on various media or translation of any part of this manual to foreign languages (without written consent of the rights owner) is prohibited.

RACOM reserves the right to make changes in the technical specification or in this product function or to terminate production of this product or to terminate its service support without previous written notification of customers.

Conditions of use of this product software abide by the license mentioned below. The program distributed by this license has been freed with the purpose to be useful, but without any specific guarantee. Under any circumstances the author or another company or person is not responsible for secondary, accidental or related damages resulting from application of this product.

The producer does not provide the user of any kind of guarantee containing assurance of suitability and usability for his application. Products are not developed, designed nor tested for utilization in devices directly affecting health and life functions of persons and animals, nor as a part of another important device, and does not provide of guarantees if the company product has been used in these aforementioned devices.

RACOM Open Software License

Version 1.0, November 2009

Copyright (c) 2001, RACOM s.r.o., Mírová 1283, Nové Město na Moravě, 592 31

Everyone can copy and spread word-for-word copies of this license, but any change is not permitted.

The program (binary version) is available for free on the contacts listed on <http://www.racom.eu>. This product contains open source or another software originating from third parties subject to GNU General Public License (GPL), GNU Library / Lesser General Public License (LGPL) and / or further author licences, declarations of responsibility exclusion and notifications. Exact terms of GPL, LGPL and some further licences is mentioned in source code packets (typically the files COPYING or LICENSE). You can obtain applicable machine-readable copies of source code of this software under GPL or LGPL licences on contacts listed on <http://www.racom.eu>. This product also includes software developed by the University of California, Berkeley and its contributors.

10.5. Warranty

RACOM-supplied parts or equipment ("equipment") is covered by warranty for inherently faulty parts and workmanship for a warranty period as stated in the delivery documentation from the date of dispatch to the customer. The warranty does not cover custom modifications to software. During the warranty period RACOM shall, on its option, fit, repair or replace ("service") faulty equipment, always provided that malfunction has occurred during normal use, not due to improper use, whether deliberate or accidental, such as attempted repair or modification by any unauthorised person; nor due to the action of abnormal or extreme environmental conditions such as overvoltage, liquid immersion or lightning strike.

Any equipment subject to repair under warranty must be returned by prepaid freight to RACOM direct. The serviced equipment shall be returned by RACOM to the customer by prepaid freight. If circumstances do not permit the equipment to be returned to RACOM, then the customer is liable and agrees to reimburse RACOM for expenses incurred by RACOM during servicing the equipment on site. When equipment does not qualify for servicing under warranty, RACOM shall charge the customer and be reimbursed for costs incurred for parts and labour at prevailing rates.

This warranty agreement represents the full extent of the warranty cover provided by RACOM to the customer, as an agreement freely entered into by both parties.

RACOM warrants the equipment to function as described, without guaranteeing it as befitting customer intent or purpose. Under no circumstances shall RACOM's liability extend beyond the above, nor shall RACOM, its principals, servants or agents be liable for any consequential loss or damage caused directly or indirectly through the use, misuse, function or malfunction of the equipment, always subject to such statutory protection as may explicitly and unavoidably apply hereto.

10.6. Declaration of Conformity



Declaration of Conformity – RAY11

In accordance with **1999/5/EC** Directive of the European Parliament and of the Council of 9th of March 1999 on radio equipment and telecommunications terminal equipment and the mutual recognition of their conformity.

Manufacturer:	RACOM	CE ⓘ
Address:	Mirova 1283, 592 31 Nove Mesto na Morave, Czech Republic	
VAT:	CZ46343423	
Product:	RAY11	
Purpose of use:	Microwave IP Bridge	

We, the manufacturer of the above mentioned product, hereby declare that:
 all essential radio test suites have been carried out and that the above named product is in conformity to all the essential requirements of the European Union directive **1999/5/EC – ANNEX III** (the technical documentation relevant to the abovementioned equipment can be made available for inspection on application to manufacturer);

The Declaration of Conformity is based on the following documents:

Spectrum:	EN 302 217-2-2 V1.4.1
EMC:	EN 301 489-1 V1.8.1, EN 301 489-4 V1.3.2
Safety:	EN 60950-1:2006

Nove Mesto na Morave, 28th of October 2013
 Jiri Hruska, CEO



RACOM s.r.o. • Mirova 1283 • 592 31 Nove Mesto na Morave • Czech Republic
 Tel.: +420 565 659 511 • Fax: +420 565 659 512 • E-mail: racom@racom.eu

www.racom.eu

ver. 2.0

Fig. 10.1: Declaration of Conformity for RAY11



Declaration of Conformity RAY17

In accordance with **1999/5/EC** Directive of the European Parliament and of the Council of 9th of March 1999 on radio equipment and telecommunications terminal equipment and the mutual recognition of their conformity.

Manufacturer: RACOM
Address: Mirova 1283, 592 31 Nove Mesto na Morave, Czech Republic
VAT: CZ46343423
Product: RAY17
Purpose of use: Microvave IP Bridge 17.1 – 17.3 GHz



We, the manufacturer of the above mentioned product, hereby declare that:
all essential radio test suites have been carried out and that the above named product is in conformity to all the essential requirements of the European Union directive **1999/5/EC** – ANNEX III (the technical documentation relevant to the abovementioned equipment can be made available for inspection on application to manufacturer);

The Declaration of Conformity is based on the following documents:
Spectrum EN 300 440-2 V1.4.1
EMC EN 301 489-1 V1.9.2
EN 301 489-4 V2.1.1
Safety EN 60950-1: 2006

Nove Mesto na Morave, 29th of October 2013
Jiri Hruska, CEO

RACOM s.r.o. • Mirova 1283 • 592 31 Nove Mesto na Morave • Czech Republic
Tel.: +420 565 659 511 • Fax: +420 565 659 512 • E-mail: racom@racom.eu

www.racom.eu

ver. 2.1

Fig. 10.2: Declaration of Conformity for RAY17



Declaration of Conformity – RAY24

In accordance with **1999/5/EC** Directive of the European Parliament and of the Council of 9th of March 1999 on radio equipment and telecommunications terminal equipment and the mutual recognition of their conformity.

Manufacturer:	RACOM	
Address:	Mirova 1283, 592 31 Nove Mesto na Morave, Czech Republic	
VAT:	CZ46343423	
Product:	RAY 24	
Purpose of use:	Microwave IP Bridge 24.0 – 24.25 GHz	CE 

We, the manufacturer of the above mentioned product, hereby declare that:
 all essential radio test suites have been carried out and that the above named product is in conformity to all the essential requirements of the European Union directive **1999/5/EC – ANNEX III** (the technical documentation relevant to the abovementioned equipment can be made available for inspection on application to manufacturer);

The Declaration of Conformity is based on the following documents:

Spectrum	EN 300 440-2 V1.4.1
EMC	EN 301 489-1 V1.8.1
	EN 301 489-4 V1.3.2
Safety	EN 60950-1: 2006

Nove Mesto na Morave, 28th of October 2013
 Jiri Hruska, CEO



RACOM s.r.o. • Mirova 1283 • 592 31 Nove Mesto na Morave • Czech Republic
 Tel.: +420 565 659 511 • Fax: +420 565 659 512 • E-mail: racom@racom.eu

www.racom.eu

ver. 1.0

Fig. 10.3: Declaration of Conformity for RAY24

10.7. Country of Origin Declaration

**RACOM**
RADIO DATA NETWORKS

Country of Origin Declaration

Manufacturer: RACOM
Address: Mirova 1283, 592 31 Nove Mesto na Morave, Czech Republic
VAT No: CZ46343423

We, the manufacturer, hereby declare that Country of Origin of the RAY microwave links and its accessories is the Czech Republic, EU.

Part Number	Description
RAY10	Unit RAY10 – 1 Gb Eth.
RAY11	Unit RAY11 – 1 Gb Eth.
RAY17	Unit RAY17 – 1 Gb Eth.
RAY24	Unit RAY24 – 1 Gb Eth.

Nove Mesto na Morave, 1 of March 2014
Jiri Hruska, CEO

RACOM s.r.o. • Mirova 1283 • 592 31 Nove Mesto na Morave • Czech Republic
Tel.: +420 565 659 511 • Fax: +420 565 659 512 • E-mail: racom@racom.eu

www.racom.eu

Fig. 10.4: Country of Origin Declaration

Appendix A. Antenna dimensions

Jirous antenna

Example antennas diameter of 68 and 90 cm. More on www.racom.eu¹.

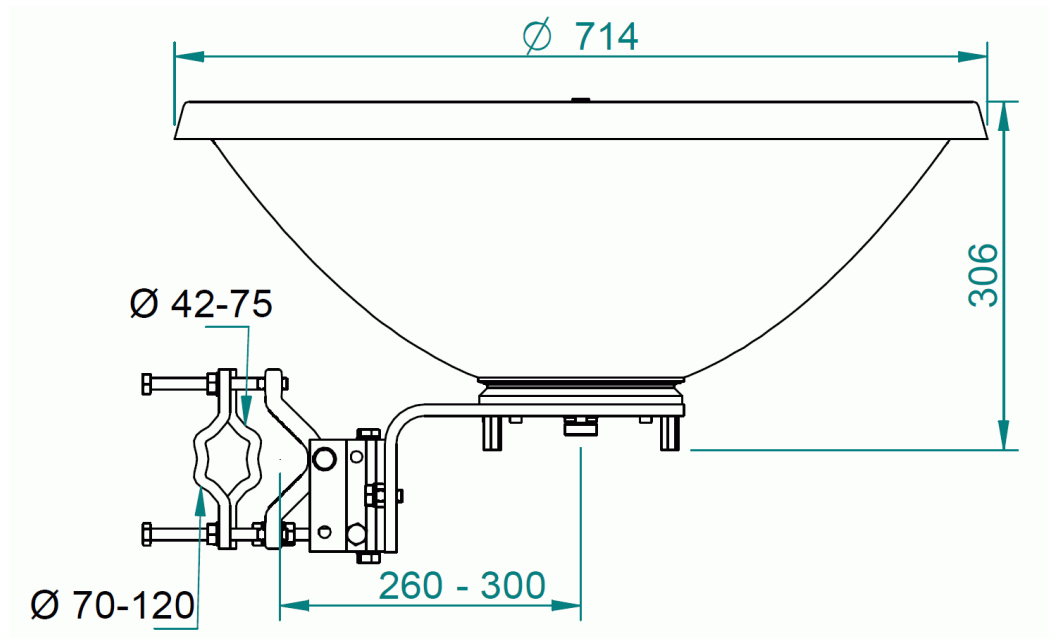

Fig. A.1: Jirous antenna 68

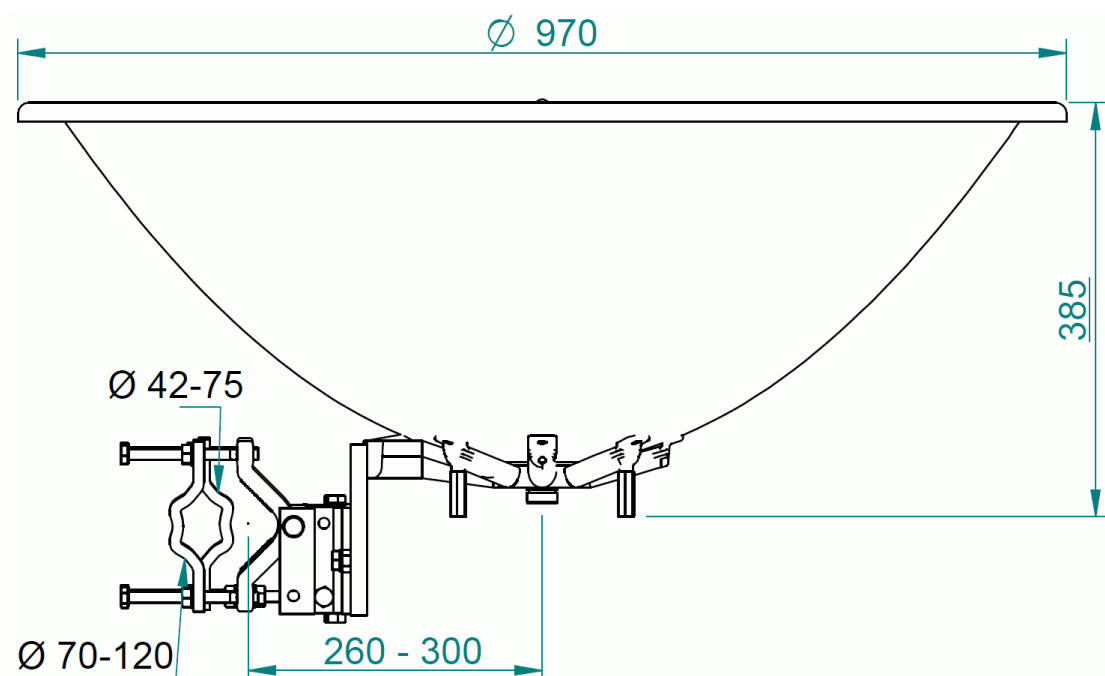
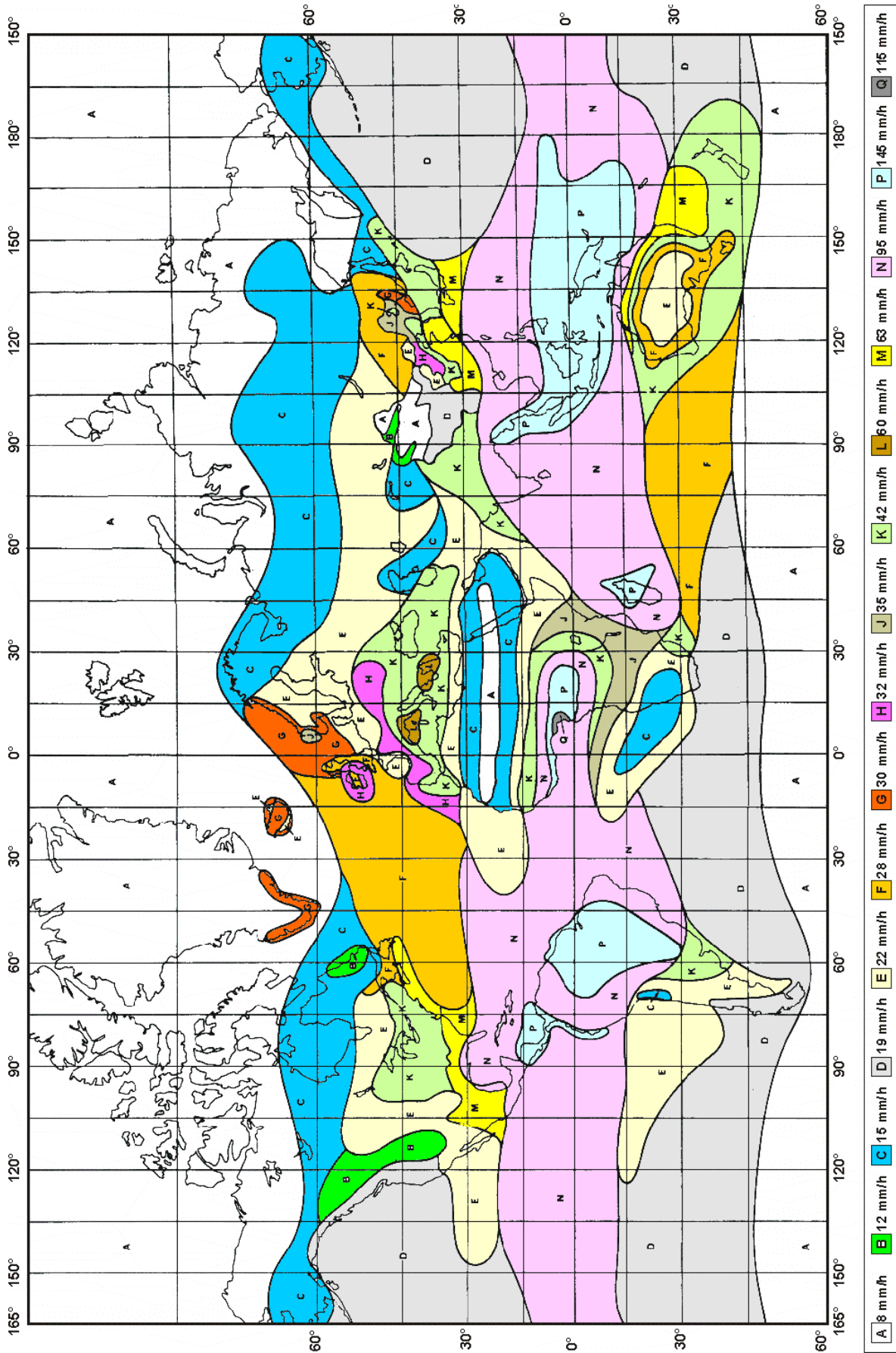

Fig. A.2: Jirous antenna 90

¹ http://www.racom.eu/eng/products/microwave-link.html#accessories_jirous

Appendix B. Rain Zone Map



Appendix C. IP address in the PC

Setting up the IP address in the PC

For configuration of the link a suitable IP address has to be set up in the PC, for example 192.168.1.233. In the next example for Windows XP we presume that the PC uses DHCP as the primary configuration.

- Open the Start menu, **Settings, Network Connections, Local Area Connection**

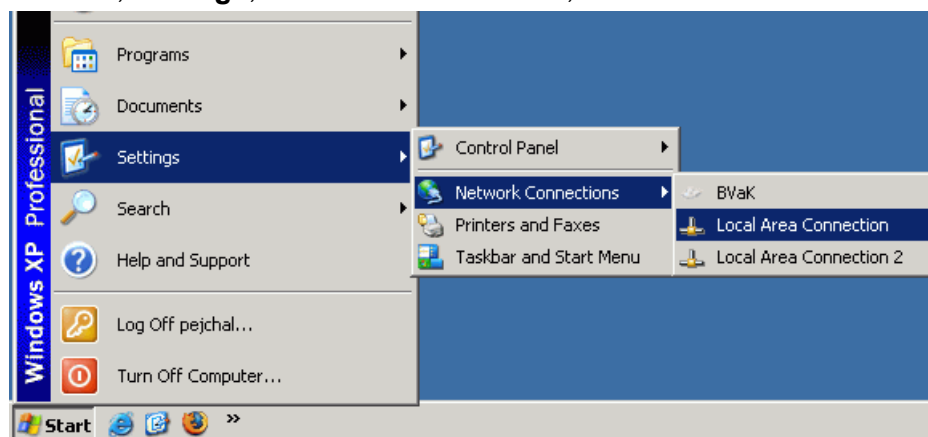

- In the window **Local Area Connection** select **Properties**

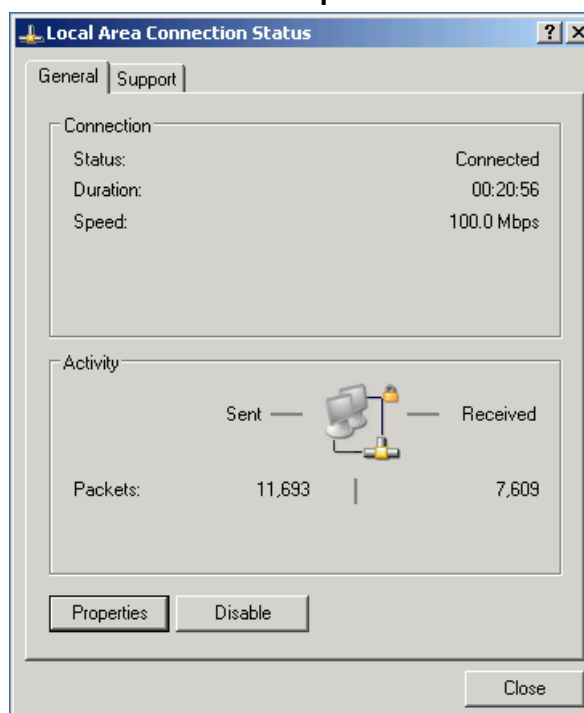

- Another window opens. Select **Internet Protocol (TCP/IP)** and click **Properties**

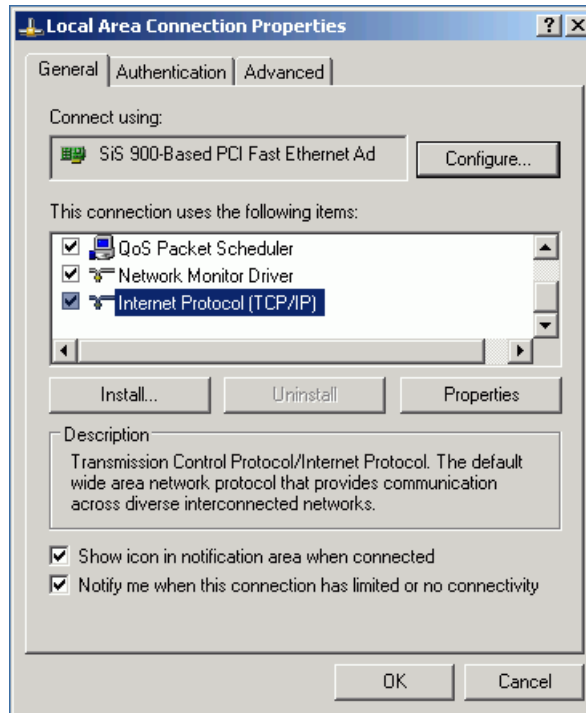

- Another window opens
- On the **General** tab select **Use the following IP address**
- Enter IP Address 192.168.1.233
- Set Subnet mask to 255.255.255.0
- Click **OK** to acknowledge this window and acknowledge the previous window in the same manner
-
- The second option is to use automatic switching. In this case on the *General* tab select, for example *Obtain an IP address from the DHCP server automatically* and address 192.168.1.233 will be seen on the Alternate configuration tab. However, this detection and subsequent switching works slower and isn't entirely reliable.
- Select tab **Alternate configuration**
- Select **User defined configuration**
- Enter IP Address 192.168.1.233
- Set Subnet mask to 255.255.255.0

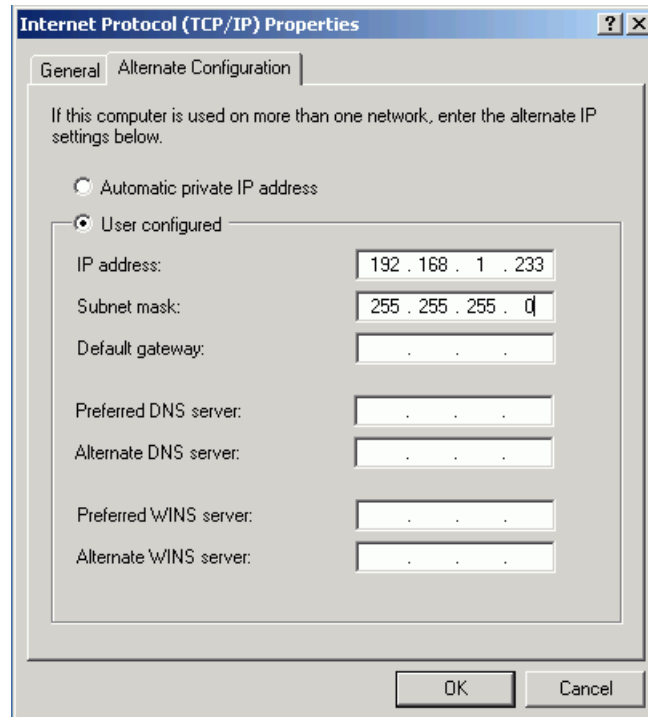

- Click **OK** to acknowledge this window and acknowledge the previous window in the same manner. If you don't use Windows XP then proceed according to the manual when setting up the IP address.

Checking the IP address in the PC

In Windows proceed in the following manner:

1. Open the Start menu and click **Run...**
2. Enter command **cmd**
3. Enter command **ipconfig** and read the PC IP address and mask:

```
C:\Documents and Settings\demo>ipconfig
Windows IP Configuration

Ethernet adapter Local Area Connection:

    Connection-specific DNS Suffix . . : racom.cz
    IP Address . . . . . : 192.168.1.233
    Subnet Mask . . . . . : 255.255.255.0
    Default Gateway . . . . . :
```

Checking the PC - radio modem connection using Ping

In Windows send a ping as follows:

1. Check the connection between the PC and the radio modem via the Ethernet cable.
2. In the Start menu click **Run...**
3. Enter command **cmd**

4. Write **ping 192.168.1.2** and press OK
5. A message appears in a window:

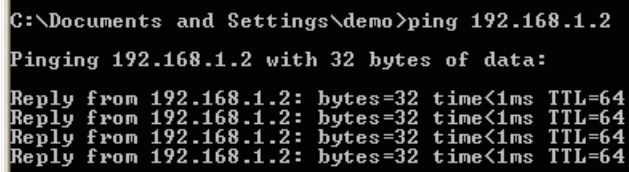

```
C:\Documents and Settings\demo>ping 192.168.1.2
Pinging 192.168.1.2 with 32 bytes of data:
Reply from 192.168.1.2: bytes=32 time<1ms TTL=64
Reply from 192.168.1.2: bytes=32 time<1ms TTL=64
Reply from 192.168.1.2: bytes=32 time<1ms TTL=64
Reply from 192.168.1.2: bytes=32 time<1ms TTL=64
```

If no communication takes place a message appears with the text "Request timed out".

If communication between the web browser and radio modem doesn't take place check the browser settings. The *Work offline* item in the *File* menu cannot be crossed out.

Appendix D. Linux key conversion

Conversion Linux key – PuTTY

To use CLI (Command Line Interface) access the unit with a PuTTY client. Access is protected by a key supplied with the RAY link. The key is in Linux format and it begins:

```
-----BEGIN DSA PRIVATE KEY-----
.....
```

or in PuTTY format which begins:

```
PuTTY-User-Key-File-2: ssh-dss
.....
```

To convert the Linux format to PuTTY do the following:

In c:\Program Files\putty\ directory run PUTTYGEN.EXE



Click on “Load” and choose the private key supplied by the manufacturer.

In the next window type your password into the *Key passphrase* and *Confirm passphrase* fields. After that click *Save private key*.

Choose location and save the key.

PuTTY access with key

In PuTTY menu fill in the address, e.g. `root@192.168.169.169` and the name of the link, e.g. *RAY 17 Racom*.

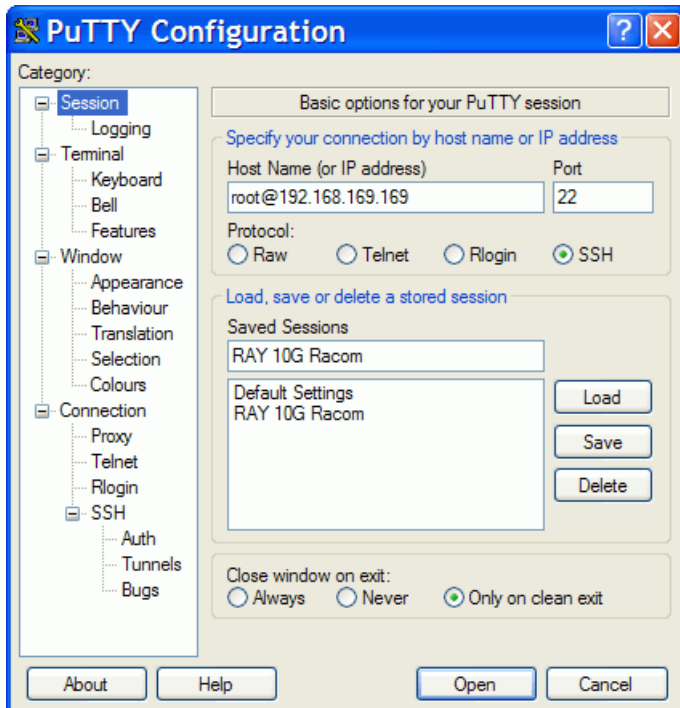

Go to *Connection / SSH / Auth* in the left column and locate the key `C:\downloads\ray.ppk`

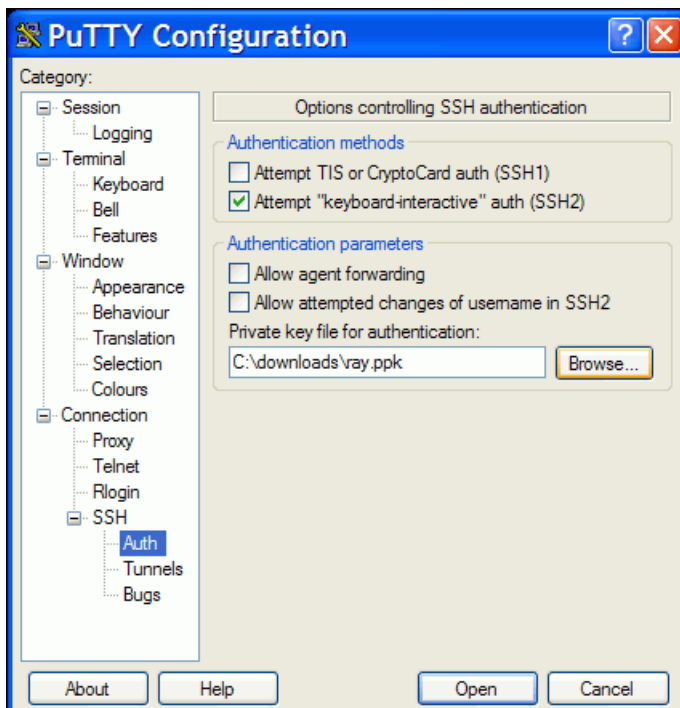

Go back to *Session* and *Save* the configuration.

To connect select the name of the connection and click *Open*. PuTTY asks for password created during key conversion.

Appendix E. Https certificate

When switching from older versions of the firmware the access certificate for https was changed. The web browser configuration has to take place in order to remove link between microwave link management IP address and previous https certificate.

Mozilla Firefox how-to:

1. https certificate
Remove management IP address from the list: Tools - Options - Advanced - Encryption - View Certificates - Servers
Another possibility: remove certificate Racom "RAY" or Racom "RACOM's product" from the list:
Tools - Options - Advanced - Encryption - View Certificates - Authorities
2. Upon the new RAY unit connection following message appear: "*This Connection is Untrusted*".
3. If you are sure that there is no security risk, choose: "*I Understand the Risks*".
4. The next step is "*Add Exception...*"
5. Finally, you have to "*Confirm Security Exception*". If the Apply button is not active, it is necessary to perform step No. 1/ and restart web browser.

Internet Explorer may give following message "*There is a problem with this website's security certificate*". Choose "*Continue to this website (not recommended)*". The address line gives you status information "*Certificate Error*". This inconvenience is caused by impossibility to create security certificate valid for list of user selected IP addresses.

Index

A

- accessories, 25
- address
 - IP in PC, 171
 - IP in RAY, 34, 81
 - MAC, 70
- antenna
 - dimensions, 23
 - Jirous dimensions, 169
- antennas, 38
- assembly, 38
 - Arkivator, 45
 - Jirous, 40
 - lubrication, 49
- authorization, 106

C

- calculation link, 10
- CLI, 103
- configuration, 65
 - link, 35
- connectors
 - arrangement, 20
 - mounting, 50
- Copyright, 5

D

- declaration of conformity, 165
- declaration of origin, 168
- default, 6, 31
- diagnostics
 - menu, 86
 - RSS indication, 61
- dimensions, 23
- directing
 - Arkivator, 47
 - calculation, 10, 62
 - indication, 60
 - Jirous, 44
 - lobes, 62

E

- environment, 162

F

- feature keys, 24, 35, 97
- FOD unit
 - assembly, 40

- connecting, 50
- description, 19
- frequency analyser, 94
- frequency configuration tables, 99
- frequency TX, 114
- Fresnel zone, 15
- function test
 - after installation, 64
 - before installation, 36

G

- grounding, 56

H

- help, 65
- https access, 31

I

- installation, 20
 - polarization, 19, 39

K

- keys
 - feature, 24, 35, 97
 - ssh access, 176
 - ssh conversion, 175

L

- LED, 22
- licensing, 162
- link
 - configuration, 35
 - length, 16
 - microwave, 8
- LLDP protocol, 81
- Lower, 19

M

- microwave link, 8
- models, 20

N

- name plate, 23

O

- ordering codes, 24

P

- parameters
 - basic, 8

setup, 64
table, 109
polarization
 cross, 39
 indication, 69
 mounting, 38

Q

QoS, 75

R

radio, 69
rain zone, 170
restart, 95
RoHS and WEEE, 162
rollback, 66, 104
RSS indication, 61

S

safety, 162
secured access, 81
serial, 68
service access, 31
settings, 71
setup
 parameters, 64
SSH access, 81, 103
start, 6, 30
start up, 60
statistics, 70
status
 bar, 67
 LED, 22
 menu, 68

T

tables
 frequencies, 114, 119
 power, 115
 radio parameters, 116
 RAy11 A,B, 115
 RAy11 C,D, 130
 RAy17, 136
 RAy24, 146
 speeds, 111
 technical parameters, 109
time, 71
tools, 91
trademark, 5
transfer speed, 69
troubleshooting, 108

U

Upper, 19

Appendix F. Revision History

Revision 1.0	2013-06-14
First issue	
Revision 1.1	2013-06-14
Added - List of documentation	
Revision 1.2	2013-08-13
Declaration of Conformity correction	
Revision 2.0	2013-08-28
Merged with the Volume 2 - Frequency and Modulation Tables	
Revision 2.1	2013-10-25
User data rate correction, RAY11 for 7 MHz / 256QAM	
Revision 2.2	2013-10-30
Signal polarization	
Revision 3.0	2013-11-05
Extended to the RAY24	
Revision 3.1	2013-12-20
RAY11-C,D channels correction	
Revision 3.2	2014-01-10
Frame rate according to RFC 2544, added	
Frequency table for Bandwidth 30 MHz, added	
Revision 3.3	2014-03-28
Link speed for CS 28/30 MHz ACAP, 256-QAM corrected	
Country of Origin Declaration added	
Jirous antenna dimensions	
Revision 3.4	2014-07-15
RAY11C,D speed and CS correction	
Revision 3.5	2014-08-12
RAY11-A,B frequency range corrected	
Revision 3.6	2015-09-23
Accessories section enhanced	