

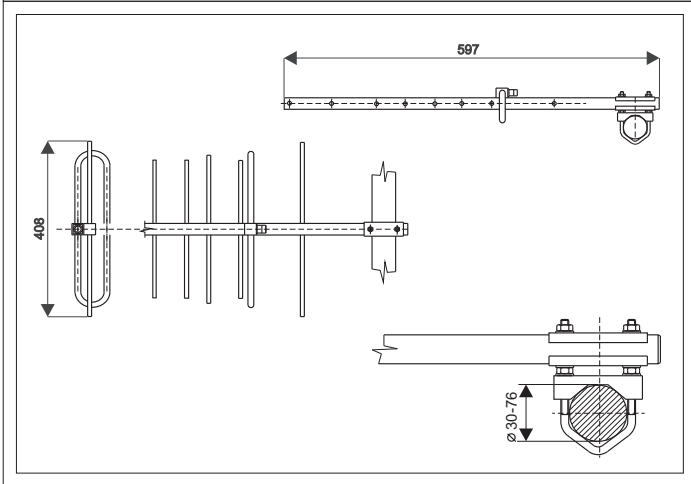

Directional Antennas

SA380.5

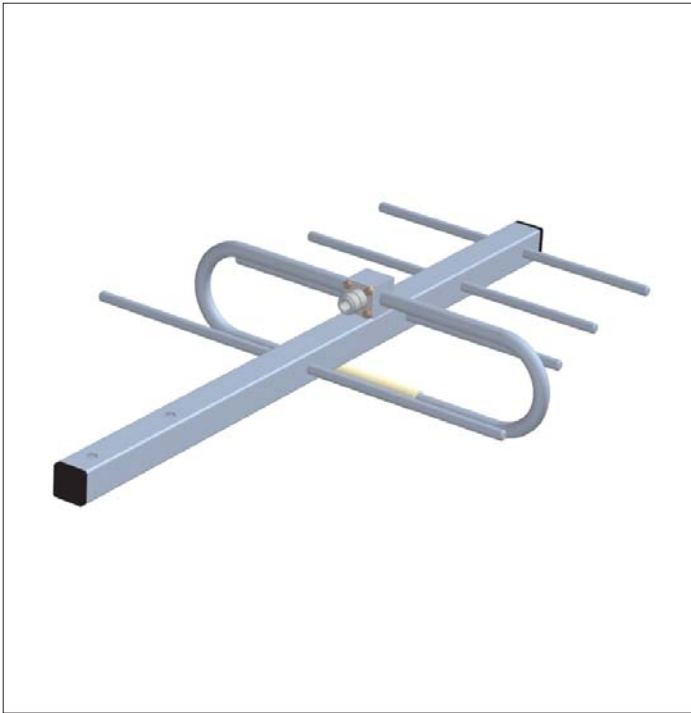

The antenna SA380.5 is designed for base radiostations working in bands of 380-410 MHz. It can be used for receiving and transmitting till 200 W. The antenna has a directional radiation pattern, is broadband and that is why it is suitable for duplex operations.

Constructionally it is designed as a five-element YAGI, made of aluminium alloy and on the surface it is covered by polyester colour. During the lightning strike the antenna is protected by a galvanic connection with the tower. The wind resistance is 150 km/h.

The antenna is connected to the coaxial cable by the coaxial plug "N" type which is soled together with this antenna.

ELECTRICAL PARAMETERS

Frequency range [MHz]	380-410
Gain [dBd]	5.6-6.6
F/B ratio [dB]	min.20
Radiation angle in E-plane [°]	61-64
Radiation angle in H-plane[°]	93-103
VSWR	<1.5
Polarization	Vertical
Impedance [Ohm]	50
Max. Input power [W]	200
Antistatic protection	All metal parts DC-grounded (shows as DC-short)

MECHANICAL PARAMETERS

Connection	N female
Wind Surface/ with 15 mm icing [m ²]	0.031 / 0.106
Wind Load/ with 15 mm icing [N]	49 / 170 @ 150 km/h
Length Boom/Driver [mm]	597 / 364
Weight [kg]	0.8
Mouting	Supplied with mast bracket suiting 30-76 mm dia.mast

RADIATION PATTERNS

E-plane	031EA05
H-plane	004KA00

Radiation Patterns code is generated with VAS97TOOL software

SWR SA380.5

