

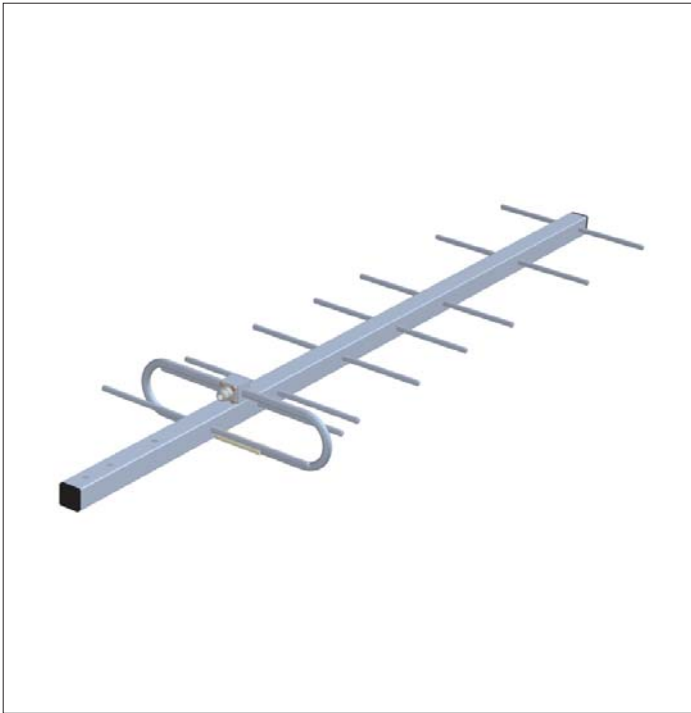

Directional Antennas

SA440.9R



The antenna SA440.9R is designed for base radiostations working in bands of 430-470 Mhz. It can be used for receiving and transmitting till 200 W. The antenna has a directional radiation pattern, is broadband and that is why it is suitable for duplex operations.

Constructionally it is designed as a nine-element YAGI, made of aluminium alloy and on the surface it is covered by polyester colour. During the lightning strike the antenna is protected by a galvanic connection with the tower. The wind resistance is 150 km/h.

The antenna is connected to the coaxial cable by the coaxial plug "N" type which is soled together with this antenna.

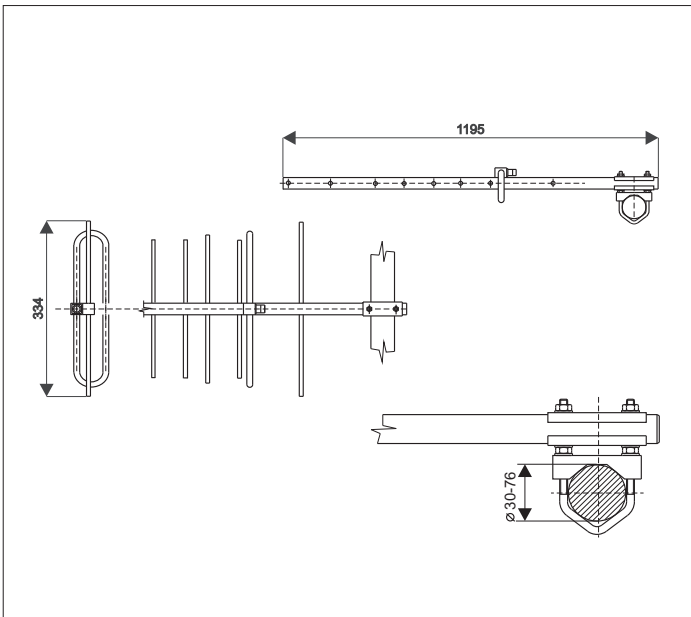

ELECTRICAL PARAMETERS

Frequency range [MHz]	430-470
Gain [dBd]	9.9-10.4
F/B ratio [dB]	min.22
Radiation angle in E-plane [°]	43-46
Radiation angle in H-plane[°]	49-53
VSWR	<1.5
Polarization	Vertical
Impedance [Ohm]	50
Max. Input power [W]	200
Antistatic protection	All metal parts DC-grounded (shows as DC-short)

MECHANICAL PARAMETERS

Connection	N female
Wind Surface/ with 15 mm icing [m ²]	0.059 / 0.183
Wind Load/ with 15 mm icing [N]	93 / 291 @ 150 km/h
Length Boom/Driver [mm]	1195 / 310
Weight [kg]	2.0
Mouting	Supplied with mast bracket suiting 30-76 mm dia.mast

RADIATION PATTERNS

E-plane	019EA02
H-plane	022EA05

Radiation Patterns code is generated with VAS97TOOL software

SWR SA440.9R

