

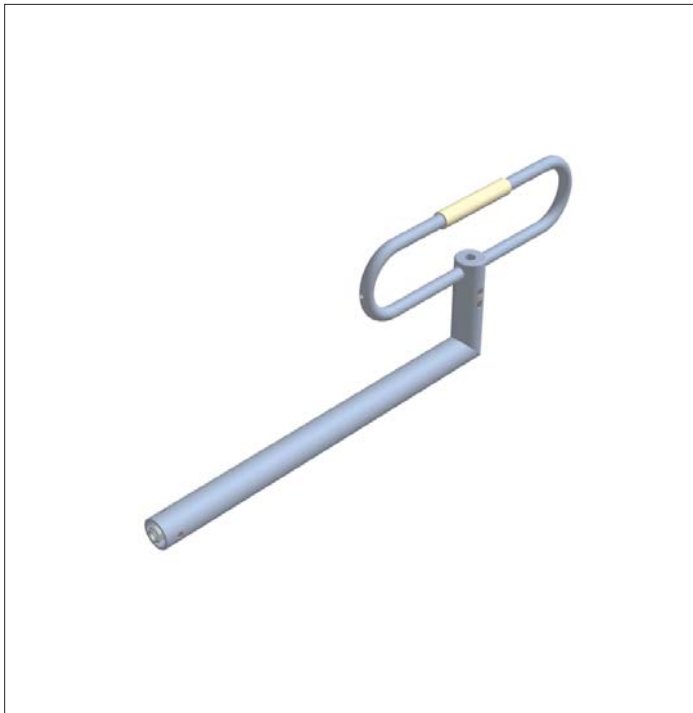

# Offset Antennas

# OV300.1



The offset antenna OV300.1 is a base antenna for radiostations working in bands of 300-355 MHz. This antenna has a slightly directional radiation pattern with the gain of 2.5 dBd. The antenna is broadband and that is why it is suitable for duplex operations.

The antenna is constructionally designed as half-wave dipole which is put on a supporting pipe. The antenna is produced of aluminium alloy and on the surface it is covered by polyester colour. During the lightning strike the antenna is protected by galvanic connection with the tower. The wind resistance is 150 km/h.

The antenna is connected to the coaxial cable by the coaxial plug "N" type which is soldered together with the antenna.

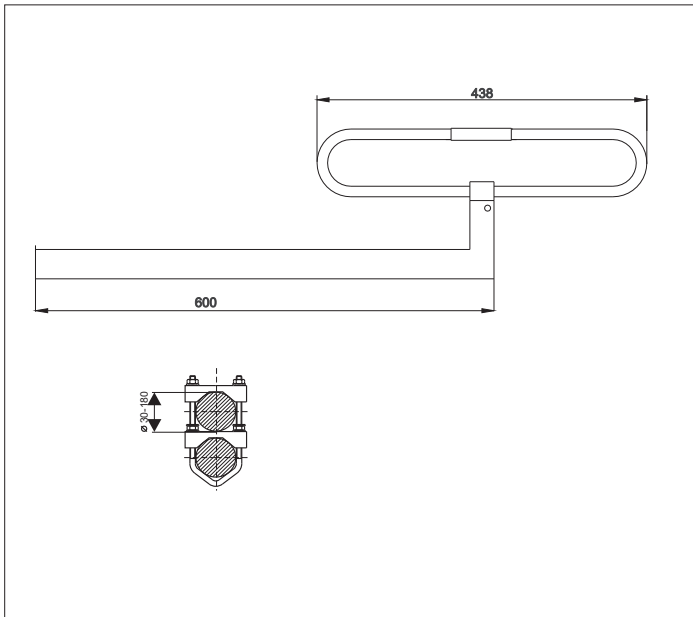

## ELECTRICAL PARAMETERS

Frequency range [MHz]	300-355
Gain [dBd]	2.0-2.5
F/B ratio [dB]	8
Radiation angle in E-plane [°]	58-62
Radiation angle in H-plane [°]	160-170
VSWR	<1.5
Polarization	Vertical
Impedance [Ohm]	50
Max. Input power [W]	200
Antistatic protection	All metal parts DC-grounded (shows as DC-short)

## MECHANICAL PARAMETERS

Connection	N female
Wind Surface/ with 15 mm icing [m²]	0.035 / 0.086
Wind Load/ with 15 mm icing [N]	55 / 138 @ 150 km/h
Length Boom/Driver [mm]	600 / 438
Weight [kg]	1.0
Mouting	Supplied with two mast bracket suitings 30-76 mm dia.mast

## RADIATION PATTERNS

E-plane	084EC00
H-plane	030EA19

Radiation Patterns code is generated with VASSTOOL software

## SWR OV300.1

